

James E. Cecchi
**CARELLA, BYRNE, CECCHI,
OLSTEIN, BRODY & AGNELLO, P.C.**
5 Becker Farm Road
Roseland, NJ 07068
Telephone: (973) 994-1700
Facsimile: (973) 994-1744
Email: jcecchi@carellabyrne.com

Christopher A. Seeger
SEEGER WEISS LLP
55 Challenger Road, 6th Floor
Ridgefield Park, NJ 07660
Telephone: (973) 639-9100
Facsimile: (973) 584-9393
Email: cseeger@seegerweiss.com

Steve W. Berman
HAGENS BERMAN SOBOL SHAPIRO LLP
1301 Second Avenue, Suite 2000
Seattle, WA 98101
Telephone: (206) 623-7292
Facsimile: (206) 623-0594
Email: steve@hbsslaw.com

*Interim Co-Lead Class Counsel
(additional counsel on signature page)*

**UNITED STATES DISTRICT COURT
DISTRICT OF NEW JERSEY**

GILLES COHEN, JOHN MICKLO,
MUHAMMAD ADNAN, DONNY WOO,
BENJAMIN MOORE, MARY LOU PLANTE,
MEREDITH MEIN DE VERA, DAN
ROSENTHAL, IGOR KRAVCHENKO,
ALEXANDRA EFANTIS, BLAISE
FONTENOT, KATHERINE MUTSCHLER,
JACQUELINE FERGUSON, BENJAMIN
CHRISTENSEN, JENNIFER LILLEY,
STEVEN BIONDO, CHANTEL NELSON,
JACQUELINE BROCKMAN, MARTY
BROWN, CHRISTINE KING, KEVIN KING,
PAULA WEEKS, MARTIN
TORRESQUINTERO, COLE SWEETON,
TROY PERRY, CHRISTINE SCHULTZ,
KATHERINE GRIFFIN, JANET OAKLEY,
ADAM WHITLEY, ROBERT KARRAT,
DAVID SROELOV, CHIARA BANCOD-HILE,
and MARK GARDENER,
individually and on behalf of all others
similarly situated,

Plaintiffs,

v.

SUBARU CORPORATION, SUBARU OF
AMERICA, INC., DENSO CORPORATION,
and DENSO INTERNATIONAL OF
AMERICA, INC.

Defendants.

Civil Action No. 1:20-cv-08442-JHR-AMD

**SECOND AMENDED CLASS ACTION
COMPLAINT**

DEMAND FOR JURY TRIAL

TABLE OF CONTENTS

	<u>Page</u>
I. INTRODUCTION	1
II. PARTIES	8
A. Plaintiffs.....	8
1. Plaintiff Gilles Cohen	10
2. Plaintiff John Micklo	11
3. Plaintiff Muhammad Adnan	13
4. Plaintiff Donny Woo.....	14
5. Plaintiff Benjamin Moore	15
6. Plaintiff Mary Lou Plante	17
7. Plaintiff Meredith Mein De Vera.....	18
8. Plaintiff Dan Rosenthal.....	19
9. Plaintiff Igor Kravchenko	21
10. Plaintiff Alexandra Efantis	22
11. Plaintiff Blaise Fontenot	23
12. Plaintiff Katherine Mutschler	24
13. Plaintiff Jacqueline Ferguson.....	26
14. Plaintiff Benjamin Christensen.....	27
15. Plaintiff Jennifer Lilley	28
16. Plaintiff Steven Biondo.....	30
17. Plaintiff Chantel Nelson.....	31
18. Plaintiff Jacqueline Brockman.....	32
19. Plaintiff Marty Brown.....	33
20. Plaintiff Christine King.....	35

21.	Plaintiff Kevin King.....	36
22.	Plaintiff Paula Weeks.....	37
23.	Plaintiff Martin Torresquintero.....	39
24.	Plaintiff Cole Sweeton	40
25.	Plaintiff Troy Perry	41
26.	Plaintiff Christine Schultz.....	42
27.	Plaintiff Katherine Griffin.....	44
28.	Plaintiff Janet Oakley.....	45
29.	Plaintiff Adam Whitely.....	46
30.	Plaintiff Chiara Bancod-Hile	48
31.	Plaintiff Roman Anderson	50
32.	Plaintiff David Sroelov	51
33.	Plaintiff Robert Karrat	53
34.	Plaintiff Mark Gardener	54
B.	Defendants	56
1.	Subaru Corporation.....	56
2.	Subaru of America, Inc.	56
3.	Denso Corporation	57
4.	Denso International of America, Inc.....	58
III.	JURISDICTION	58
IV.	VENUE.....	61
V.	FACTUAL ALLEGATIONS	61
A.	The Operation of a Low Pressure Fuel Pump.....	61
B.	The Defective Fuel Delivery Systems	66
C.	Defendants Have Not Remedied the Fuel Pump Defect in Affected Vehicles.....	70

D. NHTSA Complaints Reveal That the Fuel Pump Defect Poses Serious Safety Risks81

 1. Pre-2019 Vehicles with the Defective Pump81

 2. Recalled Vehicles.....95

 3. Other Subaru Models Not Included96

 4. Affected 2020 Vehicles.....101

E. Subaru Sells, Markets, and Advertises Subaru Brand Vehicles as Safe and Reliable103

F. Denso Marketed Itself as Synonymous with Safety and Quality109

G. Plaintiffs and Class Members Would Not Have Purchased or Leased, or Would Have Paid Less for, Affected Vehicles Had They Known of the Fuel Pump Defect112

H. Subaru Has Manipulated Its Warranty to Minimize Its Obligation to Fix the Fuel Pump Defect in Affected Vehicles112

I. Allegations Establishing Agency Relationship Between Manufacturer Subaru and Subaru Dealerships113

VI. TOLLING OF THE STATUTE OF LIMITATIONS.....116

 A. Discovery Rule Tolling.....116

 B. Fraudulent Concealment Tolling117

 C. Estoppel.....117

VII. CHOICE OF LAW ALLEGATIONS.....117

VIII. CLASS ALLEGATIONS118

 A. Claims Brought on Behalf of the Nationwide Class121

COUNT I VIOLATIONS OF 15 U.S.C. § 2301, *ET SEQ.* THE MAGNUSON-MOSS WARRANTY ACT.....121

COUNT II FRAUDULENT CONCEALMENT/OMISSION (BASED ON COMMON LAW).....124

COUNT III BREACH OF CONTRACT (COMMON LAW).....129

COUNT IV STRICT PRODUCT LIABILITY130

COUNT V NEGLIGENT RECALL/UNDERTAKING131

COUNT VI VIOLATIONS OF THE NEW JERSEY CONSUMER FRAUD
ACT (N.J. STAT. ANN. § 56:8-1, *ET SEQ.*)132

COUNT VII BREACH OF IMPLIED WARRANTY OF MERCHANTABILITY
(N.J. STAT. ANN. § 12A:2-314)134

COUNT VIII BREACH OF COVENANT OF GOOD FAITH AND FAIR
DEALING (BASED ON NEW JERSEY STATE LAW)136

COUNT IX UNJUST ENRICHMENT (COMMON LAW)138

 B. Claims Brought on Behalf of the Alabama Subclass.....139

COUNT X VIOLATIONS OF ALABAMA’S DECEPTIVE TRADE
PRACTICES ACT139

 (ALA. CODE § 8-19-1 *ET SEQ.*).....139

COUNT XI BREACH OF IMPLIED WARRANTY OF MERCHANTABILITY
(ALA. CODE §§ 7-2-314 AND 7-2A-314).....140

 C. Claims Brought on Behalf of the Arkansas Subclass142

COUNT XII VIOLATIONS OF THE DECEPTIVE TRADE PRACTICE ACT
(ARK. CODE ANN. § 4-88-101 *ET SEQ.*)142

COUNT XIII BREACH OF THE IMPLIED WARRANTY OF
MERCHANTABILITY (ARK. CODE ANN. §§ 4-2-314, 4-2A-212)144

 D. Claims Brought on Behalf of the California Subclass146

COUNT XIV VIOLATIONS OF THE CALIFORNIA UNFAIR
COMPETITION LAW (CAL. BUS. & PROF. CODE § 17200, *ET SEQ.*)146

COUNT XV VIOLATIONS OF THE CALIFORNIA CONSUMER LEGAL
REMEDIES ACT (CAL. CIV. CODE § 1750, *ET SEQ.*).....147

COUNT XVI VIOLATIONS OF THE CALIFORNIA FALSE ADVERTISING
LAW (CAL. BUS. & PROF. CODE § 17500, *ET SEQ.*).....151

COUNT XVII BREACH OF IMPLIED WARRANTIES (CAL. COM. CODE
§§ 2314, 10103, AND 10212).....152

COUNT XVIII VIOLATIONS OF SONG-BEVERLY CONSUMER
WARRANTY ACT FOR BREACH OF IMPLIED WARRANTIES
(CAL. CIV. CODE §§ 1791.1 AND 1792)154

E. Claims Brought on Behalf of the Connecticut Subclass.....157

COUNT XIX VIOLATION OF THE CONNECTICUT UNFAIR TRADE PRACTICES ACT (CONN. GEN. STAT. § 42-110A *ET SEQ.*) (As to all Defendants).....157

COUNT XX BREACH OF IMPLIED WARRANTY OF MERCHANTABILITY (CONN. GEN. STAT. § 42A-2-314) (As to Subaru)159

F. Claims Brought on Behalf of the Florida Subclass.....160

COUNT XXI VIOLATIONS OF THE FLORIDA DECEPTIVE AND UNFAIR TRADE PRACTICES ACT (“FDUTPA”) (FLA. STAT. ANN. § 501.201, *ET SEQ.*)160

COUNT XXII BREACH OF IMPLIED WARRANTY OF MERCHANTABILITY (FLA. STAT. ANN. §§ 672.314 AND 680.212).....162

COUNT XXXIII BREACH OF COVENANT OF GOOD FAITH AND FAIR DEALING (BASED ON FLORIDA STATE LAW)164

G. Claims Brought on Behalf of the Hawaii Subclass.....166

COUNT XXIV VIOLATIONS OF HAWAII’S UNFAIR DECEPTIVE ACTS AND PRACTICES STATUTE (H.R.S. § 480-1 *ET SEQ.*).....166

COUNT XXV VIOLATIONS OF HAWAII’S UNIFORM DECEPTIVE TRADE PRACTICES ACT (H.R.S. § 4801A-1 *ET SEQ.*)167

COUNT XXVI BREACH OF IMPLIED WARRANTY OF MERCHANTABILITY (H.R.S. § 490:2-314)169

H. Claims Brought on Behalf of the Illinois Subclass.....170

COUNT XXVII VIOLATION OF THE ILLINOIS CONSUMER FRAUD AND DECEPTIVE BUSINESS PRACTICES ACT (815 ILL. COMP. STAT. 505/1 *ET. SEQ.*)170

COUNT XXVIII BREACH OF THE IMPLIED WARRANTY FOR MERCHANTABILITY (810 ILL. COMP. STAT. 5/2-314)172

I. Claims Brought on Behalf of the Maryland Subclass.....174

COUNT XXIX VIOLATIONS OF THE MARYLAND CONSUMER PROTECTION ACT (MD. CODE ANN. COM. LAW. § 13-101 *ET SEQ.*).....174

COUNT XXX BREACH OF IMPLIED WARRANTY OF MERCHANTABILITY (MD. CODE COM. LAW § 2-314).....176

J. Claims Brought on Behalf of the Massachusetts Subclass178

COUNT XXXI VIOLATION OF THE MASSACHUSETTS CONSUMER PROTECTION ACT (MASS. GEN. LAWS ANN. CH 93A, § 1 *ET SEQ.*) (As to all Defendants)178

COUNT XXXII BREACH OF IMPLIED WARRANTY OF MERCHANTABILITY (MASS. GEN. LAWS ANN. CH 106, § 2-314)179

K. Claims Brought on Behalf of the Minnesota Subclass181

COUNT XXIII VIOLATION OF THE MINNESOTA PREVENTION OF CONSUMER FRAUD ACT (MINN. STAT. § 325F.68 *ET SEQ.*)181

COUNT XXXIV BREACH OF IMPLIED WARRANTY OF MERCHANTABILITY (MINN. STAT. § 336.2-314)182

COUNT XXXV BREACH OF COVENANT OF GOOD FAITH AND FAIR DEALING (BASED ON MINNESOTA STATE LAW)184

L. Claims Brought on Behalf of the Nevada Subclass185

COUNT XXXVI VIOLATIONS OF THE NEVADA DECEPTIVE TRADE PRACTICES ACT (NEV.REV. STAT. § 598.0903 *ET SEQ.*)185

COUNT XXXVII BREACH OF IMPLIED WARRANTY OF MERCHANTABILITY (NEV. REV. STAT. § 104.2314)187

M. Claims Brought on Behalf of the New York Subclass189

COUNT XXXVII VIOLATIONS OF NEW YORK GENERAL BUSINESS LAW § 349 (N.Y. GEN. BUS. LAW § 349) (As to all Defendants)189

COUNT XXXVIII VIOLATIONS OF NEW YORK GENERAL BUSINESS LAW § 350 (N.Y. GEN. BUS. LAW § 350).....191

COUNT XXXIX BREACH OF IMPLIED WARRANTY OF MERCHANTABILITY (N.Y. U.C.C. § 2-314).....193

N. Claims Brought on Behalf of the North Carolina Subclass195

COUNT XL VIOLATIONS OF THE NORTH CAROLINA UNFAIR AND DECEPTIVE TRADE PRACTICES ACT (N.C. GEN. STAT. ANN. § 75-1.1 *ET SEQ.*).....195

COUNT XLI BREACH OF THE IMPLIED WARRANTY OF MERCHANTABILITY (N.C. GEN. STAT. ANN. § 25-2-314)196

O. Claims Brought on Behalf of the Oregon Subclass198

COUNT XLII VIOLATIONS OF THE OREGON UNLAWFUL TRADE PRACTICES ACT (OR. REV. STAT. § 646.605, *ET SEQ.*).....198

COUNT XLIII BREACH OF IMPLIED WARRANTY OF MERCHANTABILITY (OR. REV. STAT. § 72-3140).....201

 P. Claims Brought on Behalf of the Pennsylvania Subclass.....202

COUNT XLIV VIOLATIONS OF THE PENNSYLVANIA UNFAIR TRADE PRACTICES AND CONSUMER PROTECTION LAW (73 P.S. § 201-1 *ET SEQ.*)203

COUNT XLV BREACH OF IMPLIED WARRANTY OF MERCHANTABILITY (13 PA. CONS. STAT. ANN. § 2314)204

 Q. Claims Brought on Behalf of the Rhode Island Subclass206

COUNT XLVI VIOLATION OF THE RHODE ISLAND UNFAIR TRADE PRACTICES AND CONSUMER PROTECTION ACT (R.I. GEN. LAWS § 6-13.1 *ET SEQ.*) (As to all Defendants)206

COUNT XLVII BREACH OF IMPLIED WARRANTY OF MERCHANTABILITY (R.I. GEN. LAWS § 6A-2-314) (As to Subaru).....208

 R. Claims Brought on Behalf of the South Carolina Subclass210

COUNT XLVIII VIOLATIONS OF THE SOUTH CAROLINA UNFAIR AND DECEPTIVE TRADE PRACTICES ACT (S.C. CODE ANN. § 39-10 *ET SEQ.*)210

COUNT XLIX BREACH OF THE IMPLIED WARRANTY OF MERCHANTABILITY (S.C. GEN. CODE ANN. § 36-2-314)212

 S. Claims Brought on Behalf of the Tennessee Subclass.....214

COUNT L VIOLATIONS OF THE TENNESSEE CONSUMER PROTECTION ACT (TEN. CODE ANN. § 47-18-101 *ET SEQ.*).....214

COUNT LI BREACH OF THE IMPLIED WARRANTY OF MERCHANTABILITY (TEN. CODE ANN. § 47-2-314)216

 T. Claims Brought on Behalf of the Texas Subclass.....218

COUNT LII VIOLATIONS OF THE TEXAS DECEPTIVE TRADE PRACTICES-CONSUMER PROTECTION ACT (“DTPA”) (TEX. BUS. & COM. CODE §§ 17.41, *ET SEQ.*) (As to all Defendants)218

COUNT LIII BREACH OF IMPLIED WARRANTY OF
MERCHANTABILITY, (TEX. BUS. & COM.
CODE §§ 2.314 AND 2A.212)219

U. Claims Brought on Behalf of the Vermont Subclass221

COUNT LIV VIOLATION OF VERMONT CONSUMER FRAUD ACT
(VT. STAT. ANN. TIT. 9, § 2451 *ET SEQ.*).....221

COUNT LV BREACH OF IMPLIED WARRANTY OF MERCHANTABILITY
(VT. STAT. ANN. TIT. 9A § 2-314.....223

V. Claims Brought on Behalf of the Washington Subclass.....225

COUNT LVII VIOLATION OF THE WASHINGTON CONSUMER
PROTECTION ACT (WASH. REV. CODE ANN. § 19.86.010 *ET SEQ.*).....225

COUNT LVIII BREACH OF IMPLIED WARRANTY OF
MERCHANTABILITY (WASH. REV. CODE ANN. § 62A.2-314)227

W. Claims Brought on Behalf of the Wisconsin Subclass229

COUNT LIX VIOLATIONS OF THE WISCONSIN DECEPTIVE TRADE
PRACTICES ACT (WIS. STAT. § 110.18).....229

REQUEST FOR RELIEF231

DEMAND FOR JURY TRIAL232

Plaintiffs Gilles Cohen, John Micklo, Muhammad Adnan, Donny Woo, Benjamin Moore, Mary Lou Plante, Meredith Mein De Vera, Dan Rosenthal, Igor Kravchenko, Alexandra Efantis, Blaise Fontenot, Katherine Mutschler, Jacqueline Ferguson, Benjamin Christensen, Jennifer Lilley, Steven Biondo, Chantel Nelson, Jacqueline Brockman, Marty Brown, Christine King, Kevin King, Paula Weeks, Martin Torresquintero, Cole Sweeton, Troy Perry, Christine Schultz, Katherine Griffin, Janet Oakley, Adam Whitley, Robert Karrat, David Sroelov, Chiara Bancod-Hile, Mark Gardener, and Roman Anderson (collectively, “Plaintiffs”) on behalf of themselves and all others similarly situated (the “Class,” defined herein), allege the following based upon the investigation of counsel and information and belief as noted.¹

I. INTRODUCTION

1. One of the most significant advancements in the internal combustion engine over the last 30 years has been the widespread adoption of fuel injection systems instead of carburetors to supply fuel to the engine. The fuel injection system uses fuel pumps to efficiently and effectively (when working correctly) manage the flow of fuel from the fuel tank to the engine in order to maintain operability and prevent engine stalling. The fuel delivery system is one of the most basic safety features in every modern car because it controls speed and keeps the engine running unless and until an operator wants to turn the engine off. If the fuel delivery system in a car is defective, then the car is unsafe to operate because it will not predictably respond to operator input to

¹ Plaintiffs submit this Second Amended Class Action Complaint to address the portion of the Court’s March 10, 2022 Opinions and Orders (ECF Nos. 111-14) regarding Count II for Fraudulent Concealment/Omission and Count VI for violation of the New Jersey Consumer Fraud Act, N.J. Stat. Ann. § 56:8-1, *et seq.* Although some of the causes of action alleged below were dismissed pursuant to the Court’s March 10, 2022 Orders, Plaintiffs are asserting them here merely to preserve them for possible appeal at the close of the litigation. The filing of this Second Amended Class Action Complaint is not intended or meant as an effort to revive such dismissed claims. In addition, Subaru significantly expanded its recall since the Consolidated Class Action Complaint was filed, which is reflected in some additional allegations.

accelerate and it could stall or completely lose power while in motion. Subaru of America, Inc., and Subaru Corporation (“Subaru”) have sold and marketed the Affected Vehicles defined below with defective low-pressure fuel pumps manufactured by Denso Corporation and Denso International America, Inc. (“Denso”) (collectively Subaru and Denso may be referred to as “Defendants”) that cause unpredictable acceleration and engine stalls and render the Affected Vehicles unsafe to operate.

2. This lawsuit arises because Defendants knew that the low-pressure fuel pumps in the vehicles identified as “Affected Vehicles” below contained a defect that causes systemic fuel system failures. Yet Defendants actively and knowingly deceived Plaintiffs and Class members by concealing the known defect and refuse to timely repair or replace such defective systems. Indeed, Subaru continues to sell—and require its customers to drive—its vehicles with the defective fuel delivery system, which could result in injuries or even deaths that could otherwise be avoided.

3. Affected Vehicles include all Subaru models that use the Denso low-pressure fuel pumps and fuel pump assemblies, including pumps that begin with part number prefix 42022-.

4. On April 27, 2020, Denso issued a recall for defective low-pressure fuel pumps it manufactured between September 1, 2017, and October 6, 2018.² The number of potentially affected vehicles across all manufacturers is 2,020,000.

5. In its Safety Recall Report filed with NHTSA, Denso admitted its fuel pumps contain a defective impeller that poses a safety hazard:

An impeller in some low pressure fuel pumps may become deformed under certain conditions which could render the fuel pump inoperable. . . . If an impeller deforms to a point that creates sufficient interference with the fuel pump body, the fuel pump becomes inoperative. According to vehicle manufacturer’s system evaluation, an inoperative fuel pump may result in the illumination of the check engine light and/or master warning indicators,

² Denso’s April Recall Report, Ex. A hereto.

rough engine running, engine no start and/or vehicle stall while driving at low speed and, in rare instances, a vehicle stall could occur while driving at higher speeds, increasing the risk of a crash.

6. Specifically, Denso stated its defective fuel pumps would become inoperable if “an impeller is manufactured with a lower density, and contains a lower surface strength or is exposed to production solvent drying for a longer period of time, higher levels of surface cracking may occur which, when excessive fuel absorption occurs, may result in impeller deformation.” (“Fuel Pump Defect”).

7. On June 11, 2020, Denso made its first expansion of the recall, increasing the number of affected fuel pumps from 2,020,000 to 2,156,057.³

8. The Denso recalls listed various manufacturers, including Subaru, that had purchased and used in their vehicles the defective fuel pumps, but failed to take any direct action on its own to remedy the hazard faced by consumers. Rather, it stated that “[t]he remedy program, if any, will be determined by vehicle manufacturers.”⁴

9. On April 16, 2020, a few days before Denso issued its recall, Subaru initiated a safety recall in the United States concerning the defective low-pressure fuel pumps by submitting a Safety Recall Report to NHTSA (the “Subaru Safety Recall Report”) voluntarily recalling over 188,000 Subaru vehicles.⁵ That recall covered the following Model Year 2019 vehicles (collectively, the “Recalled Vehicles”):

- Subaru Impreza
- Subaru Outback

³ Denso’s June Recall Report. Ex. B.

⁴ Ex A at 2.

⁵ Subaru Safety Recall Report, Ex C.

- Subaru Legacy
- Subaru Ascent

10. The Safety Recall Report identified a dangerous defect in the low-pressure fuel pump, which can fail and cause the Affected Vehicles to unexpectedly stall, sputter, and cause engine shutdown. According to the Subaru Safety Recall Report: “If the low pressure fuel pump becomes inoperative, the check engine warning light or malfunction indicator light may illuminate, and/or the engine may run rough. In the worst case, an inoperative fuel pump may result in the *engine stalling without the ability to restart the vehicle, increasing the risk of a crash.*”⁶

11. The Safety Recall Report expanded on the nature of the defect of the low-pressure pump:⁷

The affected vehicles may be equipped with a low pressure fuel pump produced during a specific timeframe which includes an impeller that was manufactured with a lower density. If the surface of the lower density impeller is exposed to solvent drying for longer periods of time, it may develop fine cracks. Those cracks may lead to excessive fuel absorption, resulting in impeller deformation. Over time, the impeller may become deformed enough to interfere with the body of the fuel pump, potentially causing the low pressure fuel pump to become inoperative.

12. The Denso Recall identifies two possible alternative causes for the Fuel Pump Defect: a low density impeller that either “contains a lower surface strength *or* is exposed to production solvent drying for a longer period of time.”⁸ However, Subaru initially limited its recall only to those vehicles with fuel pumps whose impellers were exposed to solvent for an excessive

⁶ *Id.* at 5–6.

⁷ *Id.* at 5.

⁸ Exs A & B.

period of time without regard for the fact that all the fuel pumps suffer from the material deficiency identified by Denso.⁹

13. Based on complaints to the National Highway Traffic Safety Administration (“NHTSA”), this defect has existed in Subaru vehicles since at least 2013, and continues to the present day. Indeed, other manufactures facing the same defective fuel pumps, have recalled vehicles with model years as early as 2013 and not just the 2019 model year vehicles like Subaru.

24. Again, on November 17, 2020, seven months after the initial recalls by Denso and Subaru, Denso expanded its recall, nearly doubled the months of production and, with that, the number of admittedly defective low–pressure fuel pumps with the Fuel Pump Defect. In this expansion, fuel pumps manufactured as early as June 26, 2017 and as late as June 28, 2019 were now included in the recall, and 1,517,721 additional pumps were admitted to be defective.¹⁰

15. Defendants’ apparently reluctant expansion of the recalls to address the true nature of the defect did not stop there. More than a year after Subaru announced its recall, on July 29, 2021, it issued a second recall adding another 165,026 Recalled Vehicles.¹¹ Subaru then amended this recall report on August 10, 2021,¹² and again on August 25, 2021,¹³ to ultimately add 175,698 vehicles to the tally of Recalled Vehicles, including:

- 2019-2020 Ascent
- 2018-2019 BRZ
- 2018 Forester (turbo)

⁹ Ex C.

¹⁰ Denso November Recall Report, Ex. D hereto.

¹¹ Subaru July 2021 Recall Report, Ex. E hereto.

¹² Subaru August 10, 2021 Recall Report, Ex. F hereto.

¹³ Subaru August 25, 2021 Recall Report, Ex G. hereto.

- 2018-2020 Impreza
- 2018-2020 Legacy
- 2018-2020 Outback
- 2018-2019 WRX

16. These Recalled Vehicles included 2018 model year vehicles which Defendants deliberately left on the roadways with defective fuel pumps for another year in an effort to limit their costs, as well as 2020 model year vehicles which Defendants could have endeavored to fix almost immediately after sale as part of Subaru's first recall. Moreover, as part of this recall, and as a result of this, then-pending litigation by Plaintiffs, Subaru conceded that the impellers material itself was defective, but continued to require that "exposure to solvent for longer periods of times" also have taken place.¹⁴

17. The Recalled Vehicles are just the tip of the iceberg, as there are numerous Affected Vehicles that were not included in the Recall. As of the date of the filing of this Amended Complaint, Defendants still have not acted to expand the scope of their recall or the Recalled Vehicles to match the true nature of the defect and scope of Affected Vehicles.

18. Worse still, Defendants knew of the existence of the defect years before Subaru issued its recalls and actively concealed the defect from Plaintiffs and Class members—all while claiming the Affected Vehicles were safe and dependable and that Denso's products including its fuel pumps were of high "quality, reliability and value." Defendants were not merely silent about the Fuel Pump Defect; they took affirmative steps to conceal the Fuel Pump Defect—including not disclosing the defect and delaying disclosure of the defect to the NHTSA when faced with substantial consumer complaints regarding the defective fuel pump and related safety concerns.

¹⁴ See Exhibits E-G.

19. To be sure, despite their exclusive knowledge of the Fuel Pump Defect, Defendants' partial disclosures of the relevant facts created the appearance that the engine and fuel pump in the Affected Vehicles was defect free and of the highest quality. Having volunteered to provide information to Plaintiffs and Class members, Defendants had the duty to disclose not just the partial truth, but the entire truth.

20. Further harming consumers, the repair Subaru offers to the fraction of Affected Vehicles that are subject to its recall is inadequate, falls below industry standards, and leaves owners with an incomplete "fix" of their vehicles. Rather than following the industry standard and replacing the entire fuel pump assembly, Subaru directs its technicians to replace only the fuel pump motor, which is integrated into the assembly. This is a difficult and relatively time-consuming procedure. While the additional labor costs to Subaru are off-set by substantial savings on the costs of the replacement parts, to the overall benefit of Defendants, the repair damages the fuel pump assembly leading, in the worst case, to immediate gas leaks and creating additional hazards in the near term, and shortening the safe and useful life of the fuel pump assembly on the whole. In either case, the repair does not restore the Affected Vehicles to the state they should have been in at the time of purchase, and exacerbates the Fuel Pump Defect instead of correcting it. The cost-saving measures deliver an inferior "fix."

21. For its part, Denso is equally culpable, having designed, engineered, tested, manufactured and sold millions of the defective fuel pumps, and having played an instrumental role in devising the cheaper, but inferior repair implemented by Subaru. It had exclusive knowledge of the Fuel Pump Defect since at least 2016 when, in a patent application for a more robust impeller, it acknowledged the problem with lower-density materials like those used in the

defective fuel pumps. Despite this knowledge, however, Denso never disclosed this defect to the public.

22. The Fuel Pump Defect endangers drivers, passengers, and other persons and property in the vicinity of an Affected Vehicle at any time that it is in motion. The Fuel Pump Defect thus renders the Affected Vehicles less safe and less valuable than consumers would reasonably expect and it makes them less safe and less valuable than the Affected Vehicles would be if Subaru did not design and sell the Affected Vehicles with the Fuel Pump Defect.

23. Plaintiffs accordingly bring this class action complaint to recover on behalf of the Class all relief to which they are entitled, including but not limited to recovery of the purchase price of their vehicles, compensation for overpayment and diminution in the value of their vehicles, out-of-pocket and incidental expenses, and an injunction compelling Subaru to replace or recall and fix the Affected Vehicles.

II. PARTIES

A. Plaintiffs

24. Plaintiffs and each and every Class member have suffered an ascertainable loss as a result of Subaru's omissions and/or misrepresentations associated with the Affected Vehicles, including but not limited to out-of-pocket loss and diminished value of the Affected Vehicles.

25. Neither Subaru, nor any of its agents, dealers, or other representatives, informed Plaintiffs or Class members of the Fuel Pump Defect in the Affected Vehicles prior to purchase.

26. Plaintiffs received information about the characteristics, benefits, safety, and quality of the Affected Vehicles at the dealership and/or through Subaru's extensive advertising concerning quality and safety, as intended by Subaru. None of the information Plaintiff received disclosed the Fuel Pump Defect prior to the vehicle's purchase.

27. For ease of reference, the following chart identifies the Representative Plaintiffs and their vehicles:

Representative Plaintiff	Model	Year	State
Gilles Cohen	Impreza	2019	FL
John Micklo	Ascent	2019	MN
Muhammad Adnan	Ascent	2019	CA
Donny Woo	Impreza	2019	CA
Chiara Bancod-Hite	Impreza	2015	CA
Benjamin Moore	Outback	2019	VT
Mary Lou Plante	Outback	2019	NY
Robert Karrat	Outback	2013	NY
Meredith Mein De Vera	Ascent	2019	AR
Dan Rosenthal	Forester	2019	FL
Igor Kravchenko	Impreza	2019	IL
Alexandra Efantis	Ascent	2019	MD
Blaise Fontenot	Outback	2019	MD
Katherine Mutschler	Legacy	2019	NJ
Jacqueline Ferguson	Outback	2019	NJ
Benjamin Christensen	Outback	2019	OR
Jennifer Lilley	Outback	2019	PA
Steven Biondo	Ascent	2019	RI
Chantel Nelson	Ascent	2019	TX
Mark Gardner	Legacy	2019	TX
Jacqueline Brockman	Ascent	2019	WA

Representative Plaintiff	Model	Year	State
Marty Brown	Ascent	2019	WA
Christine King	Legacy	2019	WI
Kevin King	Impreza	2019	WI
Paula Weeks	Ascent	2019	MA
Martin Torresquintero	Outback	2019	CT
Cole Sweeton	Impreza	2019	TN
Troy Perry	Ascent	2020	NC
Christine Schultz	Ascent	2019	SC
Katherine Griffin	Outback	2018	AL
Janet Oakley	Outback	2017	AL
Adam Whitley	Outback	2017	AL
Roman Anderson	Outback	2017	HI
David Sroelov	Outback	2019	NV

1. Plaintiff Gilles Cohen

28. Plaintiff Gilles Cohen is a resident of the State of Florida, domiciled in North Miami, Florida. On or about September 19, 2019, Plaintiff entered into a three-year lease agreement for a 2019 Subaru Impreza (for the purpose of this section, the “Affected Vehicle”) from Lehman Subaru Miami (an authorized Subaru dealership) in North Miami, Florida. Plaintiff has experienced stalling problems with his Affected Vehicle.

29. Unknown to Plaintiff at the time the Affected Vehicle was leased, it was equipped with a fuel delivery system that was defective and did not function safely, as advertised, or as intended by its design. Defendants’ unfair, unlawful, and deceptive conduct in designing, manufacturing, marketing, selling, and leasing the Affected Vehicle with the Fuel Pump Defect

has caused Plaintiff out-of-pocket loss, future attempted repairs, and diminished value of the Affected Vehicle.

30. Plaintiff uses the Affected Vehicle for personal and family uses. Prior to leasing the Affected Vehicle, Plaintiff reviewed the Monroney sticker that Subaru placed on the window. The window sticker advertised the Affected Vehicle's various features (such as the price, specifications, gas mileage, equipment and warranty details, and crash test ratings), and Plaintiff relied on the advertisements contained within the window sticker when deciding to lease the Affected Vehicle. The Monroney sticker did not disclose that the Affected Vehicle possessed any defects.

31. Defendants never told Plaintiff about the Fuel Pump Defect, so Plaintiff leased his Affected Vehicle on the reasonable, but mistaken, belief that his Affected Vehicle would be reliable and safe and would retain all of its operating characteristics throughout its useful life. Plaintiff specifically shopped for a Subaru vehicle because he believed Subaru's persistent advertising messaging that its vehicles were of high quality, were safe, and were reliable. None of the advertisements reviewed or representations received by Plaintiff contained any disclosure that the Affected Vehicle had a defect or the fact that Defendants would be unable to repair the defect. Had Subaru disclosed the Fuel Pump Defect, and the fact that Defendants would require Plaintiff to pay out-of-pocket costs, including repair costs to put his vehicle into the condition it should have been in but for the defect and Defendants' insufficient "fix", Plaintiff would have received these disclosures, and he would not have leased the Affected Vehicle or would have paid less for it.

2. Plaintiff John Micklo

32. Plaintiff John Micklo is a resident of the State of Minnesota, domiciled in Northfield, Minnesota. On or about August 8, 2018, Plaintiff purchased a new 2019 Subaru Ascent

(for the purpose of this section, the “Affected Vehicle”) from Bloomington Acura/Subaru (an authorized Subaru dealership) in Bloomington, Minnesota. Plaintiff has experienced loss of power problems with his Affected Vehicle, including sputtering and stalling.

33. Unknown to Plaintiff at the time the Affected Vehicle was purchased, it was equipped with a fuel delivery system that was defective and did not function safely, as advertised, or as intended by its design. Defendants’ unfair, unlawful, and deceptive conduct in designing, manufacturing, marketing, selling, and leasing the Affected Vehicle with the Fuel Pump Defect has caused Plaintiff out-of-pocket loss, future attempted repairs, and diminished value of the Affected Vehicle.

34. Plaintiff uses the Affected Vehicle for personal and family uses. Prior to purchasing the Affected Vehicle, Plaintiff reviewed the Monroney sticker that Subaru placed on the window. The window sticker advertised the Affected Vehicle’s various features (such as the price, specifications, gas mileage, equipment and warranty details, and crash test ratings), and Plaintiff relied on the advertisements contained within the window sticker when deciding to purchase the Affected Vehicle. The Monroney sticker did not disclose that the Affected Vehicle possessed any defects.

35. Defendants never told Plaintiff about the Fuel Pump Defect, so Plaintiff purchased his Affected Vehicle on the reasonable, but mistaken, belief that his Affected Vehicle would be reliable and safe and would retain all of its operating characteristics throughout its useful life. Plaintiff specifically shopped for a Subaru vehicle because he believed Subaru’s persistent advertising messaging that its vehicles were of high quality, were safe, and were reliable. None of the advertisements reviewed or representations received by Plaintiff contained any disclosure that the Affected Vehicle had a defect or the fact that Subaru would be unable to repair the defect. Had

Defendants disclosed the Fuel Pump Defect, and the fact that Defendants would require Plaintiff to pay out-of-pocket costs, including repair costs, to put his vehicle into the condition it should have been in but for the defect and Defendants' insufficient "fix", Plaintiff would have received these disclosures, and he would not have purchased the Affected Vehicle or would have paid less for it.

3. Plaintiff Muhammad Adnan

36. Plaintiff Muhammad Adnan is a resident of the State of California, domiciled in Long Beach, California. On or about January 14, 2019, Plaintiff purchased a new 2019 Subaru Ascent (for purposes of this section, the "Affected Vehicle") at Santa Monica Subaru (an authorized Subaru Dealership) in Santa Monica, California. Plaintiff has experienced loss of power problems with his Affected Vehicle, including sputtering and stalling.

37. Unknown to Plaintiff at the time the Affected Vehicle was purchased, it was equipped with a fuel delivery system that was defective and did not function safely, as advertised, or as intended by its design. Defendants' unfair, unlawful, and deceptive conduct in designing, manufacturing, marketing, selling, and leasing the Affected Vehicle with the Fuel Pump Defect has caused Plaintiff out-of-pocket loss, future attempted repairs, and diminished value of the Affected Vehicle.

38. Plaintiff uses the Affected Vehicle for personal and family uses. Prior to purchasing the Affected Vehicle, Plaintiff reviewed the Monroney sticker that Subaru placed on the window. The window sticker advertised the Affected Vehicle's various features (such as the price, specifications, gas mileage, equipment and warranty details, and crash test ratings), and Plaintiff relied on the advertisements contained within the window sticker when deciding to purchase the Affected Vehicle. The Monroney sticker did not disclose that the Affected Vehicle possessed any defects.

39. Defendants never told Plaintiff about the Fuel Pump Defect, so Plaintiff purchased his Affected Vehicle on the reasonable, but mistaken, belief that his Affected Vehicle would be reliable and safe and would retain all of its operating characteristics throughout its useful life. Plaintiff specifically shopped for a Subaru vehicle because he believed Subaru's persistent advertising messaging that its vehicles were of high quality, were safe, and were reliable. None of the advertisements reviewed or representations received by Plaintiff contained any disclosure that the Affected Vehicle had a defect or the fact that Subaru would be unable to repair the defect. Had Defendants disclosed the Fuel Pump Defect, and the fact that Defendants would require Plaintiff to pay out-of-pocket costs, including repair costs, to put his vehicle into the condition it should have been in but for the defect and Defendants' insufficient "fix", Plaintiff would have received these disclosures, and he would not have purchased the Affected Vehicle or would have paid less for it.

4. Plaintiff Donny Woo

40. Plaintiff Donny Woo is a resident of the State of California, domiciled in the city of Martinez, California. On or about January 19, 2019, Plaintiff purchased a new 2019 Subaru Impreza (for purposes of this section, the "Affected Vehicle") at Diablo Subaru of Walnut Creek (an authorized Subaru Dealership) in Walnut Creek, California. Plaintiff has experienced loss of power problems with his Affected Vehicle, including sputtering and stalling.

41. Unknown to Plaintiff at the time the Affected Vehicle was purchased, it was equipped with a fuel delivery system that was defective and did not function safely, as advertised, or as intended by its design. Defendants' unfair, unlawful, and deceptive conduct in designing, manufacturing, marketing, selling, and leasing the Affected Vehicle with the Fuel Pump Defect has caused Plaintiff out-of-pocket loss, future attempted repairs, and diminished value of the Affected Vehicle.

42. Plaintiff uses the Affected Vehicle for personal and family uses. Prior to purchasing the Affected Vehicle, Plaintiff reviewed the Monroney sticker that Subaru placed on the window. The window sticker advertised the Affected Vehicle's various features (such as the price, specifications, gas mileage, equipment and warranty details, and crash test ratings), and Plaintiff relied on the advertisements contained within the window sticker when deciding to purchase the Affected Vehicle. The Monroney sticker did not disclose that the Affected Vehicle possessed any defects.

43. Defendants never told Plaintiff about the Fuel Pump Defect, so Plaintiff purchased his Affected Vehicle on the reasonable, but mistaken, belief that his Affected Vehicle would be reliable and safe and would retain all of its operating characteristics throughout its useful life. Plaintiff specifically shopped for a Subaru vehicle because he believed Subaru's persistent advertising messaging that its vehicles were of high quality, were safe, and were reliable. None of the advertisements reviewed or representations received by Plaintiff contained any disclosure that the Affected Vehicle had a defect or the fact that Subaru would be unable to repair the defect. Had Defendants disclosed the Fuel Pump Defect, and the fact that Defendants would require Plaintiff to pay out-of-pocket costs, including repair costs, to put his vehicle into the condition it should have been in but for the defect and Defendants' insufficient "fix", Plaintiff would have received these disclosures, and he would not have purchased the Affected Vehicle or would have paid less for it.

5. Plaintiff Benjamin Moore

44. Plaintiff Benjamin Moore is a resident of the State of New York, domiciled in the city of Schenectady, New York. On or about December 1, 2018, Plaintiff purchased a new 2019 Subaru Outback (for purposes of this section, the "Affected Vehicle") at Bennington Subaru (an

authorized Subaru Dealership) in Bennington, Vermont. Plaintiff has experienced loss of power problems with his Affected Vehicle, including sputtering and stalling.

45. Unknown to Plaintiff at the time the Affected Vehicle was purchased, it was equipped with a fuel delivery system that was defective and did not function safely, as advertised, or as intended by its design. Defendants' unfair, unlawful, and deceptive conduct in designing, manufacturing, marketing, selling, and leasing the Affected Vehicle with the Fuel Pump Defect has caused Plaintiff out-of-pocket loss, future attempted repairs, and diminished value of the Affected Vehicle.

46. Plaintiff uses the Affected Vehicle for personal and family uses. Prior to purchasing the Affected Vehicle, Plaintiff reviewed the Monroney sticker that Subaru placed on the window. The window sticker advertised the Affected Vehicle's various features (such as the price, specifications, gas mileage, equipment and warranty details, and crash test ratings), and Plaintiff relied on the advertisements contained within the window sticker when deciding to purchase the Affected Vehicle. The Monroney sticker did not disclose that the Affected Vehicle possessed any defects.

47. Defendants never told Plaintiff about the Fuel Pump Defect, so Plaintiff purchased his Affected Vehicle on the reasonable, but mistaken, belief that his Affected Vehicle would be reliable and safe and would retain all of its operating characteristics throughout its useful life. Plaintiff specifically shopped for a Subaru vehicle because he believed Subaru's persistent advertising messaging that its vehicles were of high quality, were safe, and were reliable. None of the advertisements reviewed or representations received by Plaintiff contained any disclosure that the Affected Vehicle had a defect or the fact that Subaru would be unable to repair the defect. Had Defendants disclosed the Fuel Pump Defect, and the fact that Defendants would require Plaintiff

to pay out-of-pocket costs, including repair costs, to put his vehicle into the condition it should have been in but for the defect and Defendants' insufficient "fix", Plaintiff would have received these disclosures, and he would not have purchased the Affected Vehicle or would have paid less for it.

6. Plaintiff Mary Lou Plante

48. Plaintiff Mary Lou Plante is a resident of the State of New York, domiciled in the city of Liverpool, New York. On or about November 1, 2018, Plaintiff purchased a new 2019 Subaru Outback (for purposes of this section, the "Affected Vehicle") at Romano Subaru (an authorized Subaru Dealership) in Syracuse, New York. Plaintiff has experienced loss of power problems with her Affected Vehicle, including sputtering and stalling.

49. Unknown to Plaintiff at the time the Affected Vehicle was purchased, it was equipped with a fuel delivery system that was defective and did not function safely, as advertised, or as intended by its design. Defendants' unfair, unlawful, and deceptive conduct in designing, manufacturing, marketing, selling, and leasing the Affected Vehicle with the Fuel Pump Defect has caused Plaintiff out-of-pocket loss, future attempted repairs, and diminished value of the Affected Vehicle.

50. Plaintiff uses the Affected Vehicle for personal and family uses. Prior to purchasing the Affected Vehicle, Plaintiff reviewed the Monroney sticker that Subaru placed on the window. The window sticker advertised the Affected Vehicle's various features (such as the price, specifications, gas mileage, equipment and warranty details, and crash test ratings), and Plaintiff relied on the advertisements contained within the window sticker when deciding to purchase the Affected Vehicle. The Monroney sticker did not disclose that the Affected Vehicle possessed any defects.

51. Defendants never told Plaintiff about the Fuel Pump Defect, so Plaintiff purchased her Affected Vehicle on the reasonable, but mistaken, belief that her Affected Vehicle would be reliable and safe and would retain all of its operating characteristics throughout its useful life. Plaintiff specifically shopped for a Subaru vehicle because she believed Subaru's persistent advertising messaging that its vehicles were of high quality, were safe, and were reliable. None of the advertisements reviewed or representations received by Plaintiff contained any disclosure that the Affected Vehicle had a defect or the fact that Subaru would be unable to repair the defect. Had Defendants disclosed the Fuel Pump Defect, and the fact that Defendants would require Plaintiff to pay out-of-pocket costs, including repair costs, to put her vehicle into the condition it should have been in but for the defect and Defendants' insufficient "fix", Plaintiff would have received these disclosures, and she would not have purchased the Affected Vehicle or would have paid less for it.

7. Plaintiff Meredith Mein De Vera

52. Plaintiff Mary Meredith Mein De Vera is a resident of the State of Arkansas, domiciled in the city of Rogers, Arkansas. On or about August 1, 2018, Plaintiff purchased a new 2019 Subaru Ascent (for purposes of this section, the "Affected Vehicle") at Adventure Subaru (an authorized Subaru Dealership) in Fayetteville, Arkansas. Plaintiff has experienced loss of power problems with her Affected Vehicle, including sputtering and stalling.

53. Unknown to Plaintiff at the time the Affected Vehicle was purchased, it was equipped with a fuel delivery system that was defective and did not function safely, as advertised, or as intended by its design. Defendants' unfair, unlawful, and deceptive conduct in designing, manufacturing, marketing, selling, and leasing the Affected Vehicle with the Fuel Pump Defect has caused Plaintiff out-of-pocket loss, future attempted repairs, and diminished value of the Affected Vehicle.

54. Plaintiff uses the Affected Vehicle for personal and family uses. Prior to purchasing the Affected Vehicle, Plaintiff reviewed the Monroney sticker that Subaru placed on the window. The window sticker advertised the Affected Vehicle's various features (such as the price, specifications, gas mileage, equipment and warranty details, and crash test ratings), and Plaintiff relied on the advertisements contained within the window sticker when deciding to purchase the Affected Vehicle. The Monroney sticker did not disclose that the Affected Vehicle possessed any defects.

55. Defendants never told Plaintiff about the Fuel Pump Defect, so Plaintiff purchased his Affected Vehicle on the reasonable, but mistaken, belief that his Affected Vehicle would be reliable and safe and would retain all of its operating characteristics throughout its useful life. Plaintiff specifically shopped for a Subaru vehicle because he believed Subaru's persistent advertising messaging that its vehicles were of high quality, were safe, and were reliable. None of the advertisements reviewed or representations received by Plaintiff contained any disclosure that the Affected Vehicle had a defect or the fact that Subaru would be unable to repair the defect. Had Defendants disclosed the Fuel Pump Defect, and the fact that Defendants would require Plaintiff to pay out-of-pocket costs, including repair costs, to put her vehicle into the condition it should have been in but for the defect and Defendants' insufficient "fix", Plaintiff would have received these disclosures, and he would not have purchased the Affected Vehicle or would have paid less for it.

8. Plaintiff Dan Rosenthal

56. Plaintiff Dan Rosenthal is a resident of the State of Florida, domiciled in the city of Tampa, Florida. On or about November 23, 2018, Plaintiff purchased a new 2019 Subaru Forester (for purposes of this section, the "Affected Vehicle") at Reeves Subaru (an authorized Subaru Dealership) in Tampa, Florida.

57. Unknown to Plaintiff at the time the Affected Vehicle was purchased, it was equipped with a fuel delivery system that was defective and did not function safely, as advertised, or as intended by its design. Defendants' unfair, unlawful, and deceptive conduct in designing, manufacturing, marketing, selling, and leasing the Affected Vehicle with the Fuel Pump Defect has caused Plaintiff out-of-pocket loss, future attempted repairs, and diminished value of the Affected Vehicle.

58. Plaintiff uses the Affected Vehicle for personal and family uses. Prior to purchasing the Affected Vehicle, Plaintiff reviewed the Monroney sticker that Subaru placed on the window. The window sticker advertised the Affected Vehicle's various features (such as the price, specifications, gas mileage, equipment and warranty details, and crash test ratings), and Plaintiff relied on the advertisements contained within the window sticker when deciding to purchase the Affected Vehicle. The Monroney sticker did not disclose that the Affected Vehicle possessed any defects.

59. Defendants never told Plaintiff about the Fuel Pump Defect, so Plaintiff purchased his Affected Vehicle on the reasonable, but mistaken, belief that his Affected Vehicle would be reliable and safe and would retain all of its operating characteristics throughout its useful life. Plaintiff specifically shopped for a Subaru vehicle because he believed Subaru's persistent advertising messaging that its vehicles were of high quality, were safe, and were reliable. None of the advertisements reviewed or representations received by Plaintiff contained any disclosure that the Affected Vehicle had a defect or the fact that Subaru would be unable to repair the defect. Had Defendants disclosed the Fuel Pump Defect, and the fact that Defendants would require Plaintiff to pay out-of-pocket costs, including repair costs, to put his vehicle into the condition it should have been in but for the defect and Defendants' insufficient "fix", Plaintiff would have received

these disclosures, and he would not have purchased the Affected Vehicle or would have paid less for it.

9. Plaintiff Igor Kravchenko

60. Plaintiff Igor Kravchenko is a resident of the State of Illinois, domiciled in the city of Northbrook, IL. On or about December 4, 2018, Plaintiff purchased a new 2019 Subaru Impreza (for purposes of this section, the “Affected Vehicle”) at Liberty Auto Subaru (an authorized Subaru Dealership) in Libertyville, Illinois. Plaintiff has experienced loss of power problems with his Affected Vehicle, including sputtering and stalling.

61. Unknown to Plaintiff at the time the Affected Vehicle was purchased, it was equipped with a fuel delivery system that was defective and did not function safely, as advertised, or as intended by its design. Defendants’ unfair, unlawful, and deceptive conduct in designing, manufacturing, marketing, selling, and leasing the Affected Vehicle with the Fuel Pump Defect has caused Plaintiff out-of-pocket loss, future attempted repairs, and diminished value of the Affected Vehicle.

62. Plaintiff uses the Affected Vehicle for personal and family uses. Prior to purchasing the Affected Vehicle, Plaintiff reviewed the Monroney sticker that Subaru placed on the window. The window sticker advertised the Affected Vehicle’s various features (such as the price, specifications, gas mileage, equipment and warranty details, and crash test ratings), and Plaintiff relied on the advertisements contained within the window sticker when deciding to purchase the Affected Vehicle. The Monroney sticker did not disclose that the Affected Vehicle possessed any defects.

63. Defendants never told Plaintiff about the Fuel Pump Defect, so Plaintiff purchased his Affected Vehicle on the reasonable, but mistaken, belief that his Affected Vehicle would be reliable and safe and would retain all of its operating characteristics throughout its useful life.

Plaintiff specifically shopped for a Subaru vehicle because he believed Subaru's persistent advertising messaging that its vehicles were of high quality, were safe, and were reliable. None of the advertisements reviewed or representations received by Plaintiff contained any disclosure that the Affected Vehicle had a defect or the fact that Subaru would be unable to repair the defect. Had Defendants disclosed the Fuel Pump Defect, and the fact that Defendants would require Plaintiff to pay out-of-pocket costs, including repair costs, to put his vehicle into the condition it should have been in but for the defect and Defendants' insufficient "fix", Plaintiff would have received these disclosures, and he would not have purchased the Affected Vehicle or would have paid less for it.

10. Plaintiff Alexandra Efantis

64. Plaintiff Alexandra Efantis is a resident of the State of Maryland, domiciled in the city of Crofton, Maryland. On or about October 1, 2018, Plaintiff purchased a new 2019 Subaru Ascent (for purposes of this section, the "Affected Vehicle") at Annapolis Subaru (an authorized Subaru Dealership) in Annapolis, Maryland.

65. Unknown to Plaintiff at the time the Affected Vehicle was purchased, it was equipped with a fuel delivery system that was defective and did not function safely, as advertised, or as intended by its design. Defendants' unfair, unlawful, and deceptive conduct in designing, manufacturing, marketing, selling, and leasing the Affected Vehicle with the Fuel Pump Defect has caused Plaintiff out-of-pocket loss, future attempted repairs, and diminished value of the Affected Vehicle.

66. Plaintiff uses the Affected Vehicle for personal and family uses. Prior to purchasing the Affected Vehicle, Plaintiff reviewed the Monroney sticker that Subaru placed on the window. The window sticker advertised the Affected Vehicle's various features (such as the price, specifications, gas mileage, equipment and warranty details, and crash test ratings), and Plaintiff

relied on the advertisements contained within the window sticker when deciding to purchase the Affected Vehicle. The Monrone y sticker did not disclose that the Affected Vehicle possessed any defects.

67. Defendants never told Plaintiff about the Fuel Pump Defect, so Plaintiff purchased his Affected Vehicle on the reasonable, but mistaken, belief that his Affected Vehicle would be reliable and safe and would retain all of its operating characteristics throughout its useful life. Plaintiff specifically shopped for a Subaru vehicle because he believed Subaru's persistent advertising messaging that its vehicles were of high quality, were safe, and were reliable. None of the advertisements reviewed or representations received by Plaintiff contained any disclosure that the Affected Vehicle had a defect or the fact that Subaru would be unable to repair the defect. Had Defendants disclosed the Fuel Pump Defect, and the fact that Defendants would require Plaintiff to pay out-of-pocket costs, including repair costs, to put her vehicle into the condition it should have been in but for the defect and Defendants' insufficient "fix", Plaintiff would have received these disclosures, and he would not have purchased the Affected Vehicle or would have paid less for it.

11. Plaintiff Blaise Fontenot

68. Plaintiff Blaise Fontenot is a resident of the State of Maryland, domiciled in the city of Fulton, Maryland. On or about July 1, 2019, Plaintiff purchased a new 2019 Subaru Outback (for purposes of this section, the "Affected Vehicle") at Heritage Subaru (an authorized Subaru Dealership) in Baltimore, Maryland.

69. Unknown to Plaintiff at the time the Affected Vehicle was purchased, it was equipped with a fuel delivery system that was defective and did not function safely, as advertised, or as intended by its design. Defendants' unfair, unlawful, and deceptive conduct in designing, manufacturing, marketing, selling, and leasing the Affected Vehicle with the Fuel Pump Defect

has caused Plaintiff out-of-pocket loss, future attempted repairs, and diminished value of the Affected Vehicle.

70. Plaintiff uses the Affected Vehicle for personal and family uses. Prior to purchasing the Affected Vehicle, Plaintiff reviewed the Monroney sticker that Subaru placed on the window. The window sticker advertised the Affected Vehicle's various features (such as the price, specifications, gas mileage, equipment and warranty details, and crash test ratings), and Plaintiff relied on the advertisements contained within the window sticker when deciding to purchase the Affected Vehicle. The Monroney sticker did not disclose that the Affected Vehicle possessed any defects.

71. Defendants never told Plaintiff about the Fuel Pump Defect, so Plaintiff purchased his Affected Vehicle on the reasonable, but mistaken, belief that his Affected Vehicle would be reliable and safe and would retain all of its operating characteristics throughout its useful life. Plaintiff specifically shopped for a Subaru vehicle because he believed Subaru's persistent advertising messaging that its vehicles were of high quality, were safe, and were reliable. None of the advertisements reviewed or representations received by Plaintiff contained any disclosure that the Affected Vehicle had a defect or the fact that Subaru would be unable to repair the defect. Had Defendants disclosed the Fuel Pump Defect, and the fact that Defendants would require Plaintiff to pay out-of-pocket costs, including repair costs, to put their vehicle into the condition it should have been in but for the defect and Defendants' insufficient "fix", Plaintiff would have received these disclosures, and he would not have purchased the Affected Vehicle or would have paid less for it.

12. Plaintiff Katherine Mutschler

72. Plaintiff Katherine Mutschler is a resident of the State of New Jersey, domiciled in the city of Galloway, New Jersey. On or about July 1, 2019, Plaintiff purchased a new 2019 Subaru

Legacy (for purposes of this section, the “Affected Vehicle”) at Annapolis Subaru (an authorized Subaru Dealership) in Pleasantville, New Jersey.

73. Unknown to Plaintiff at the time the Affected Vehicle was purchased, it was equipped with a fuel delivery system that was defective and did not function safely, as advertised, or as intended by its design. Defendants’ unfair, unlawful, and deceptive conduct in designing, manufacturing, marketing, selling, and leasing the Affected Vehicle with the Fuel Pump Defect has caused Plaintiff out-of-pocket loss, future attempted repairs, and diminished value of the Affected Vehicle.

74. Plaintiff uses the Affected Vehicle for personal and family uses. Prior to purchasing the Affected Vehicle, Plaintiff reviewed the Monroney sticker that Subaru placed on the window. The window sticker advertised the Affected Vehicle’s various features (such as the price, specifications, gas mileage, equipment and warranty details, and crash test ratings), and Plaintiff relied on the advertisements contained within the window sticker when deciding to purchase the Affected Vehicle. The Monroney sticker did not disclose that the Affected Vehicle possessed any defects.

75. Defendants never told Plaintiff about the Fuel Pump Defect, so Plaintiff purchased her Affected Vehicle on the reasonable, but mistaken, belief that his Affected Vehicle would be reliable and safe and would retain all of its operating characteristics throughout its useful life. Plaintiff specifically shopped for a Subaru vehicle because she believed Subaru’s persistent advertising messaging that its vehicles were of high quality, were safe, and were reliable. None of the advertisements reviewed or representations received by Plaintiff contained any disclosure that the Affected Vehicle had a defect or the fact that Subaru would be unable to repair the defect. Had Defendants disclosed the Fuel Pump Defect, and the fact that Defendants would require Plaintiff

to pay out-of-pocket costs, including repair costs, to put her vehicle into the condition it should have been in but for the defect and Defendants' insufficient "fix", Plaintiff would have received these disclosures, and he would not have purchased the Affected Vehicle or would have paid less for it.

13. Plaintiff Jacqueline Ferguson

76. Plaintiff Jacqueline Ferguson is a resident of the State of New Jersey, domiciled in the city of Edison, New Jersey. On or about August 1, 2019, Plaintiff purchased a new 2019 Subaru Outback (for purposes of this section, the "Affected Vehicle") at World Subaru (an authorized Subaru Dealership) in Tinton Falls, New Jersey.

77. Unknown to Plaintiff at the time the Affected Vehicle was purchased, it was equipped with a fuel delivery system that was defective and did not function safely, as advertised, or as intended by its design. Defendants' unfair, unlawful, and deceptive conduct in designing, manufacturing, marketing, selling, and leasing the Affected Vehicle with the Fuel Pump Defect has caused Plaintiff out-of-pocket loss, future attempted repairs, and diminished value of the Affected Vehicle.

78. Plaintiff uses the Affected Vehicle for personal and family uses. Prior to purchasing the Affected Vehicle, Plaintiff reviewed the Monroney sticker that Subaru placed on the window. The window sticker advertised the Affected Vehicle's various features (such as the price, specifications, gas mileage, equipment and warranty details, and crash test ratings), and Plaintiff relied on the advertisements contained within the window sticker when deciding to purchase the Affected Vehicle. The Monroney sticker did not disclose that the Affected Vehicle possessed any defects.

79. Defendants never told Plaintiff about the Fuel Pump Defect, so Plaintiff purchased her Affected Vehicle on the reasonable, but mistaken, belief that his Affected Vehicle would be

reliable and safe and would retain all of its operating characteristics throughout its useful life. Plaintiff specifically shopped for a Subaru vehicle because she believed Subaru's persistent advertising messaging that its vehicles were of high quality, were safe, and were reliable. None of the advertisements reviewed or representations received by Plaintiff contained any disclosure that the Affected Vehicle had a defect or the fact that Subaru would be unable to repair the defect. Had Defendants disclosed the Fuel Pump Defect, and the fact that Defendants would require Plaintiff to pay out-of-pocket costs, including repair costs, to put her vehicle into the condition it should have been in but for the defect and Defendants' insufficient "fix", Plaintiff would have received these disclosures, and he would not have purchased the Affected Vehicle or would have paid less for it.

14. Plaintiff Benjamin Christensen

80. Plaintiff Benjamin Christensen is a resident of the State of Oregon, domiciled in the city of Gladstone, Oregon. On or about July 1, 2019, Plaintiff purchased a new 2019 Subaru Outback (for purposes of this section, the "Affected Vehicle") at Royal Moore Auto Center (an authorized Subaru Dealership) in Hillsboro, Oregon.

81. Unknown to Plaintiff at the time the Affected Vehicle was purchased, it was equipped with a fuel delivery system that was defective and did not function safely, as advertised, or as intended by its design. Defendants' unfair, unlawful, and deceptive conduct in designing, manufacturing, marketing, selling, and leasing the Affected Vehicle with the Fuel Pump Defect has caused Plaintiff out-of-pocket loss, future attempted repairs, and diminished value of the Affected Vehicle.

82. Plaintiff uses the Affected Vehicle for personal and family uses. Prior to purchasing the Affected Vehicle, Plaintiff reviewed the Monroney sticker that Subaru placed on the window. The window sticker advertised the Affected Vehicle's various features (such as the price,

specifications, gas mileage, equipment and warranty details, and crash test ratings), and Plaintiff relied on the advertisements contained within the window sticker when deciding to purchase the Affected Vehicle. The Monrone sticker did not disclose that the Affected Vehicle possessed any defects.

83. Defendants never told Plaintiff about the Fuel Pump Defect, so Plaintiff purchased his Affected Vehicle on the reasonable, but mistaken, belief that his Affected Vehicle would be reliable and safe and would retain all of its operating characteristics throughout its useful life. Plaintiff specifically shopped for a Subaru vehicle because he believed Subaru's persistent advertising messaging that its vehicles were of high quality, were safe, and were reliable. None of the advertisements reviewed or representations received by Plaintiff contained any disclosure that the Affected Vehicle had a defect or the fact that Subaru would be unable to repair the defect. Had Defendants disclosed the Fuel Pump Defect, and the fact that Defendants would require Plaintiff to pay out-of-pocket costs, including repair costs, to put his vehicle into the condition it should have been in but for the defect and Defendants' insufficient "fix", Plaintiff would have received these disclosures, and he would not have purchased the Affected Vehicle or would have paid less for it.

15. Plaintiff Jennifer Lilley

84. Plaintiff Jennifer Lilley is a resident of the State of Pennsylvania, domiciled in the city of Fogesville, Pennsylvania. On or about March 1, 2019, Plaintiff leased a new 2019 Subaru Outback (for purposes of this section, the "Affected Vehicle") at Ciocca Subaru (an authorized Subaru Dealership) in Allentown, Pennsylvania. Plaintiff has experienced loss of power problems with her Affected Vehicle, including sputtering and stalling.

85. Unknown to Plaintiff at the time the Affected Vehicle was purchased, it was equipped with a fuel delivery system that was defective and did not function safely, as advertised,

or as intended by its design. Defendants' unfair, unlawful, and deceptive conduct in designing, manufacturing, marketing, selling, and leasing the Affected Vehicle with the Fuel Pump Defect has caused Plaintiff out-of-pocket loss, future attempted repairs, and diminished value of the Affected Vehicle.

86. Plaintiff uses the Affected Vehicle for personal and family uses. Prior to purchasing the Affected Vehicle, Plaintiff reviewed the Monroney sticker that Subaru placed on the window. The window sticker advertised the Affected Vehicle's various features (such as the price, specifications, gas mileage, equipment and warranty details, and crash test ratings), and Plaintiff relied on the advertisements contained within the window sticker when deciding to purchase the Affected Vehicle. The Monroney sticker did not disclose that the Affected Vehicle possessed any defects.

87. Defendants never told Plaintiff about the Fuel Pump Defect, so Plaintiff purchased her Affected Vehicle on the reasonable, but mistaken, belief that his Affected Vehicle would be reliable and safe and would retain all of its operating characteristics throughout its useful life. Plaintiff specifically shopped for a Subaru vehicle because she believed Subaru's persistent advertising messaging that its vehicles were of high quality, were safe, and were reliable. None of the advertisements reviewed or representations received by Plaintiff contained any disclosure that the Affected Vehicle had a defect or the fact that Subaru would be unable to repair the defect. Had Defendants disclosed the Fuel Pump Defect, and the fact that Defendants would require Plaintiff to pay out-of-pocket costs, including repair costs, to put her vehicle into the condition it should have been in but for the defect and Defendants' insufficient "fix", Plaintiff would have received these disclosures, and he would not have purchased the Affected Vehicle or would have paid less for it.

16. Plaintiff Steven Biondo

88. Plaintiff Steven Biondo is a resident of the State of Rhode Island, domiciled in the city of North Kingstown, Rhode Island. On or about July 1, 2019, Plaintiff purchased a new 2019 Subaru Ascent (for purposes of this section, the “Affected Vehicle”) at Balise Subaru (an authorized Subaru Dealership) in West Warwick, Rhode Island.

89. Unknown to Plaintiff at the time the Affected Vehicle was purchased, it was equipped with a fuel delivery system that was defective and did not function safely, as advertised, or as intended by its design. Defendants’ unfair, unlawful, and deceptive conduct in designing, manufacturing, marketing, selling, and leasing the Affected Vehicle with the Fuel Pump Defect has caused Plaintiff out-of-pocket loss, future attempted repairs, and diminished value of the Affected Vehicle.

90. Plaintiff uses the Affected Vehicle for personal and family uses. Prior to purchasing the Affected Vehicle, Plaintiff reviewed the Monroney sticker that Subaru placed on the window. The window sticker advertised the Affected Vehicle’s various features (such as the price, specifications, gas mileage, equipment and warranty details, and crash test ratings), and Plaintiff relied on the advertisements contained within the window sticker when deciding to purchase the Affected Vehicle. The Monroney sticker did not disclose that the Affected Vehicle possessed any defects.

91. Defendants never told Plaintiff about the Fuel Pump Defect, so Plaintiff purchased his Affected Vehicle on the reasonable, but mistaken, belief that his Affected Vehicle would be reliable and safe and would retain all of its operating characteristics throughout its useful life. Plaintiff specifically shopped for a Subaru vehicle because he believed Subaru’s persistent advertising messaging that its vehicles were of high quality, were safe, and were reliable. None of the advertisements reviewed or representations received by Plaintiff contained any disclosure that

the Affected Vehicle had a defect or the fact that Subaru would be unable to repair the defect. Had Defendants disclosed the Fuel Pump Defect, and the fact that Defendants would require Plaintiff to pay out-of-pocket costs, including repair costs, to put his vehicle into the condition it should have been in but for the defect and Defendants' insufficient "fix", Plaintiff would have received these disclosures, and he would not have purchased the Affected Vehicle or would have paid less for it.

17. Plaintiff Chantel Nelson

92. Plaintiff Chantel Nelson is a resident of the State of Texas, domiciled in the city of Irving, Texas. On or about February 1, 2019, Plaintiff purchased a new 2019 Subaru Ascent (for purposes of this section, the "Affected Vehicle") at Ewing Subaru (an authorized Subaru Dealership) in Plano, Texas. Plaintiff has experienced loss of power problems with her Affected Vehicle, including sputtering and stalling.

93. Unknown to Plaintiff at the time the Affected Vehicle was purchased, it was equipped with a fuel delivery system that was defective and did not function safely, as advertised, or as intended by its design. Defendants' unfair, unlawful, and deceptive conduct in designing, manufacturing, marketing, selling, and leasing the Affected Vehicle with the Fuel Pump Defect has caused Plaintiff out-of-pocket loss, future attempted repairs, and diminished value of the Affected Vehicle.

94. Plaintiff uses the Affected Vehicle for personal and family uses. Prior to purchasing the Affected Vehicle, Plaintiff reviewed the Monroney sticker that Subaru placed on the window. The window sticker advertised the Affected Vehicle's various features (such as the price, specifications, gas mileage, equipment and warranty details, and crash test ratings), and Plaintiff relied on the advertisements contained within the window sticker when deciding to purchase the

Affected Vehicle. The Monroney sticker did not disclose that the Affected Vehicle possessed any defects.

95. Defendants never told Plaintiff about the Fuel Pump Defect, so Plaintiff purchased her Affected Vehicle on the reasonable, but mistaken, belief that her Affected Vehicle would be reliable and safe and would retain all of its operating characteristics throughout its useful life. Plaintiff specifically shopped for a Subaru vehicle because she believed Subaru's persistent advertising messaging that its vehicles were of high quality, were safe, and were reliable. None of the advertisements reviewed or representations received by Plaintiff contained any disclosure that the Affected Vehicle had a defect or the fact that Subaru would be unable to repair the defect. Had Defendants disclosed the Fuel Pump Defect, and the fact that Defendants would require Plaintiff to pay out-of-pocket costs, including repair costs, to put her vehicle into the condition it should have been in but for the defect and Defendants' insufficient "fix", Plaintiff would have received these disclosures, and he would not have purchased the Affected Vehicle or would have paid less for it.

18. Plaintiff Jacqueline Brockman

96. Plaintiff Jacqueline Brockman is a resident of the State of Washington, domiciled in the city of Lacey, Washington. On or about April 1, 2019, Plaintiff purchased a new 2019 Subaru Ascent (for purposes of this section, the "Affected Vehicle") at Hanson Subaru (an authorized Subaru Dealership) in Olympia, Washington. Plaintiff has experienced loss of power problems with her Affected Vehicle, including sputtering and stalling.

97. Unknown to Plaintiff at the time the Affected Vehicle was purchased, it was equipped with a fuel delivery system that was defective and did not function safely, as advertised, or as intended by its design. Defendants' unfair, unlawful, and deceptive conduct in designing, manufacturing, marketing, selling, and leasing the Affected Vehicle with the Fuel Pump Defect

has caused Plaintiff out-of-pocket loss, future attempted repairs, and diminished value of the Affected Vehicle.

98. Plaintiff uses the Affected Vehicle for personal and family uses. Prior to purchasing the Affected Vehicle, Plaintiff reviewed the Monroney sticker that Subaru placed on the window. The window sticker advertised the Affected Vehicle's various features (such as the price, specifications, gas mileage, equipment and warranty details, and crash test ratings), and Plaintiff relied on the advertisements contained within the window sticker when deciding to purchase the Affected Vehicle. The Monroney sticker did not disclose that the Affected Vehicle possessed any defects.

99. Defendants never told Plaintiff about the Fuel Pump Defect, so Plaintiff purchased her Affected Vehicle on the reasonable, but mistaken, belief that her Affected Vehicle would be reliable and safe and would retain all of its operating characteristics throughout its useful life. Plaintiff specifically shopped for a Subaru vehicle because she believed Subaru's persistent advertising messaging that its vehicles were of high quality, were safe, and were reliable. None of the advertisements reviewed or representations received by Plaintiff contained any disclosure that the Affected Vehicle had a defect or the fact that Subaru would be unable to repair the defect. Had Defendants disclosed the Fuel Pump Defect, and the fact that Defendants would require Plaintiff to pay out-of-pocket costs, including repair costs, to put her vehicle into the condition it should have been in but for the defect and Defendants' insufficient "fix", Plaintiff would have received these disclosures, and he would not have purchased the Affected Vehicle or would have paid less for it.

19. Plaintiff Marty Brown

100. Plaintiff Marty Brown is a resident of the State of Washington, domiciled in the city of Bremerton, Washington. On or about January 1, 2019, Plaintiff purchased a new 2019

Subaru Ascent (for purposes of this section, the “Affected Vehicle”) at Peninsula Subaru (an authorized Subaru Dealership) in Bremerton, Washington. Plaintiff has experienced loss of power problems with his Affected Vehicle, including sputtering and stalling.

101. Unknown to Plaintiff at the time the Affected Vehicle was purchased, it was equipped with a fuel delivery system that was defective and did not function safely, as advertised, or as intended by its design. Defendants’ unfair, unlawful, and deceptive conduct in designing, manufacturing, marketing, selling, and leasing the Affected Vehicle with the Fuel Pump Defect has caused Plaintiff out-of-pocket loss, future attempted repairs, and diminished value of the Affected Vehicle.

102. Plaintiff uses the Affected Vehicle for personal and family uses. Prior to purchasing the Affected Vehicle, Plaintiff reviewed the Monroney sticker that Subaru placed on the window. The window sticker advertised the Affected Vehicle’s various features (such as the price, specifications, gas mileage, equipment and warranty details, and crash test ratings), and Plaintiff relied on the advertisements contained within the window sticker when deciding to purchase the Affected Vehicle. The Monroney sticker did not disclose that the Affected Vehicle possessed any defects.

103. Defendants never told Plaintiff about the Fuel Pump Defect, so Plaintiff purchased his Affected Vehicle on the reasonable, but mistaken, belief that his Affected Vehicle would be reliable and safe and would retain all of its operating characteristics throughout its useful life. Plaintiff specifically shopped for a Subaru vehicle because he believed Subaru’s persistent advertising messaging that its vehicles were of high quality, were safe, and were reliable. None of the advertisements reviewed or representations received by Plaintiff contained any disclosure that the Affected Vehicle had a defect or the fact that Subaru would be unable to repair the defect. Had

Defendants disclosed the Fuel Pump Defect, and the fact that Defendants would require Plaintiff to pay out-of-pocket costs, including repair costs, to put his vehicle into the condition it should have been in but for the defect and Defendants' insufficient "fix", Plaintiff would have received these disclosures, and he would not have purchased the Affected Vehicle or would have paid less for it.

20. Plaintiff Christine King

104. Plaintiff Christine King is a resident of the State of Wisconsin, domiciled in the city of Kenosha, Wisconsin. On or about April 1, 2019, Plaintiff purchased a new 2019 Subaru Ascent (for purposes of this section, the "Affected Vehicle") at Kenosha Subaru (an authorized Subaru Dealership) in Kenosha, Wisconsin.

105. Unknown to Plaintiff at the time the Affected Vehicle was purchased, it was equipped with a fuel delivery system that was defective and did not function safely, as advertised, or as intended by its design. Defendants' unfair, unlawful, and deceptive conduct in designing, manufacturing, marketing, selling, and leasing the Affected Vehicle with the Fuel Pump Defect has caused Plaintiff out-of-pocket loss, future attempted repairs, and diminished value of the Affected Vehicle.

106. Plaintiff uses the Affected Vehicle for personal and family uses. Prior to purchasing the Affected Vehicle, Plaintiff reviewed the Monroney sticker that Subaru placed on the window. The window sticker advertised the Affected Vehicle's various features (such as the price, specifications, gas mileage, equipment and warranty details, and crash test ratings), and Plaintiff relied on the advertisements contained within the window sticker when deciding to purchase the Affected Vehicle. The Monroney sticker did not disclose that the Affected Vehicle possessed any defects.

107. Defendants never told Plaintiff about the Fuel Pump Defect, so Plaintiff purchased her Affected Vehicle on the reasonable, but mistaken, belief that her Affected Vehicle would be reliable and safe and would retain all of its operating characteristics throughout its useful life. Plaintiff specifically shopped for a Subaru vehicle because she believed Subaru's persistent advertising messaging that its vehicles were of high quality, were safe, and were reliable. None of the advertisements reviewed or representations received by Plaintiff contained any disclosure that the Affected Vehicle had a defect or the fact that Subaru would be unable to repair the defect. Had Defendants disclosed the Fuel Pump Defect, and the fact that Defendants would require Plaintiff to pay out-of-pocket costs, including repair costs, to put her vehicle into the condition it should have been in but for the defect and Defendants' insufficient "fix", Plaintiff would have received these disclosures, and he would not have purchased the Affected Vehicle or would have paid less for it.

21. Plaintiff Kevin King

108. Plaintiff Kevin King is a resident of the State of Wisconsin, domiciled in the city of Shawano, Wisconsin. On or about September 1, 2019, Plaintiff purchased a new 2019 Subaru Impreza (for purposes of this section, the "Affected Vehicle") at Kocourek Subaru (an authorized Subaru Dealership) in Wausau, Wisconsin.

109. Unknown to Plaintiff at the time the Affected Vehicle was purchased, it was equipped with a fuel delivery system that was defective and did not function safely, as advertised, or as intended by its design. Defendants' unfair, unlawful, and deceptive conduct in designing, manufacturing, marketing, selling, and leasing the Affected Vehicle with the Fuel Pump Defect has caused Plaintiff out-of-pocket loss, future attempted repairs, and diminished value of the Affected Vehicle.

110. Plaintiff uses the Affected Vehicle for personal and family uses. Prior to purchasing the Affected Vehicle, Plaintiff reviewed the Monroney sticker that Subaru placed on the window. The window sticker advertised the Affected Vehicle's various features (such as the price, specifications, gas mileage, equipment and warranty details, and crash test ratings), and Plaintiff relied on the advertisements contained within the window sticker when deciding to purchase the Affected Vehicle. The Monroney sticker did not disclose that the Affected Vehicle possessed any defects.

111. Defendants never told Plaintiff about the Fuel Pump Defect, so Plaintiff purchased his Affected Vehicle on the reasonable, but mistaken, belief that his Affected Vehicle would be reliable and safe and would retain all of its operating characteristics throughout its useful life. Plaintiff specifically shopped for a Subaru vehicle because he believed Subaru's persistent advertising messaging that its vehicles were of high quality, were safe, and were reliable. None of the advertisements reviewed or representations received by Plaintiff contained any disclosure that the Affected Vehicle had a defect or the fact that Subaru would be unable to repair the defect. Had Defendants disclosed the Fuel Pump Defect, and the fact that Defendants would require Plaintiff to pay out-of-pocket costs, including repair costs, to put his vehicle into the condition it should have been in but for the defect and Defendants' insufficient "fix", Plaintiff would have received these disclosures, and he would not have purchased the Affected Vehicle or would have paid less for it.

22. Plaintiff Paula Weeks

112. Plaintiff Paula Weeks is a resident of the State of Connecticut, domiciled in the city of Stamford, Connecticut. On or about October 1, 2018, Plaintiff purchased a new 2019 Subaru Ascent (for purposes of this section, the "Affected Vehicle") at Long Subaru (an authorized Subaru Dealership) in Webster, Massachusetts.

113. Unknown to Plaintiff at the time the Affected Vehicle was purchased, it was equipped with a fuel delivery system that was defective and did not function safely, as advertised, or as intended by its design. Defendants' unfair, unlawful, and deceptive conduct in designing, manufacturing, marketing, selling, and leasing the Affected Vehicle with the Fuel Pump Defect has caused Plaintiff out-of-pocket loss, future attempted repairs, and diminished value of the Affected Vehicle.

114. Plaintiff uses the Affected Vehicle for personal and family uses. Prior to purchasing the Affected Vehicle, Plaintiff reviewed the Monroney sticker that Subaru placed on the window. The window sticker advertised the Affected Vehicle's various features (such as the price, specifications, gas mileage, equipment and warranty details, and crash test ratings), and Plaintiff relied on the advertisements contained within the window sticker when deciding to purchase the Affected Vehicle. The Monroney sticker did not disclose that the Affected Vehicle possessed any defects.

115. Defendants never told Plaintiff about the Fuel Pump Defect, so Plaintiff purchased her Affected Vehicle on the reasonable, but mistaken, belief that her Affected Vehicle would be reliable and safe and would retain all of its operating characteristics throughout its useful life. Plaintiff specifically shopped for a Subaru vehicle because she believed Subaru's persistent advertising messaging that its vehicles were of high quality, were safe, and were reliable. None of the advertisements reviewed or representations received by Plaintiff contained any disclosure that the Affected Vehicle had a defect or the fact that Subaru would be unable to repair the defect. Had Defendants disclosed the Fuel Pump Defect, and the fact that Defendants would require Plaintiff to pay out-of-pocket costs, including repair costs, to put her vehicle into the condition it should have been in but for the defect and Defendants' insufficient "fix", Plaintiff would have received

these disclosures, and he would not have purchased the Affected Vehicle or would have paid less for it.

23. Plaintiff Martin Torresquintero

116. Plaintiff Martin Torresquintero is a resident of the State of Connecticut, domiciled in the city of New Haven, Connecticut. On or about July 1, 2019, Plaintiff purchased a new 2019 Subaru Outback (for purposes of this section, the “Affected Vehicle”) at Dan Perkins Subaru (an authorized Subaru Dealership) in Milford, Connecticut.

117. Unknown to Plaintiff at the time the Affected Vehicle was purchased, it was equipped with a fuel delivery system that was defective and did not function safely, as advertised, or as intended by its design. Defendants’ unfair, unlawful, and deceptive conduct in designing, manufacturing, marketing, selling, and leasing the Affected Vehicle with the Fuel Pump Defect has caused Plaintiff out-of-pocket loss, future attempted repairs, and diminished value of the Affected Vehicle.

118. Plaintiff uses the Affected Vehicle for personal and family uses. Prior to purchasing the Affected Vehicle, Plaintiff reviewed the Monroney sticker that Subaru placed on the window. The window sticker advertised the Affected Vehicle’s various features (such as the price, specifications, gas mileage, equipment and warranty details, and crash test ratings), and Plaintiff relied on the advertisements contained within the window sticker when deciding to purchase the Affected Vehicle. The Monroney sticker did not disclose that the Affected Vehicle possessed any defects.

119. Defendants never told Plaintiff about the Fuel Pump Defect, so Plaintiff purchased his Affected Vehicle on the reasonable, but mistaken, belief that his Affected Vehicle would be reliable and safe and would retain all of its operating characteristics throughout its useful life. Plaintiff specifically shopped for a Subaru vehicle because he believed Subaru’s persistent

advertising messaging that its vehicles were of high quality, were safe, and were reliable. None of the advertisements reviewed or representations received by Plaintiff contained any disclosure that the Affected Vehicle had a defect or the fact that Subaru would be unable to repair the defect. Had Defendants disclosed the Fuel Pump Defect, and the fact that Defendants would require Plaintiff to pay out-of-pocket costs, including repair costs, to put his vehicle into the condition it should have been in but for the defect and Defendants' insufficient "fix", Plaintiff would have received these disclosures, and he would not have purchased the Affected Vehicle or would have paid less for it.

24. Plaintiff Cole Sweeton

120. Plaintiff Cole Sweeton is a resident of the State of Georgia, domiciled in the city of Chickanauga, Georgia. On or about August 1, 2019, Plaintiff purchased a new 2019 Subaru Impreza (for purposes of this section, the "Affected Vehicle") at Kelly Subaru (an authorized Subaru Dealership) in Chattanooga, Tennessee.

121. Unknown to Plaintiff at the time the Affected Vehicle was purchased, it was equipped with a fuel delivery system that was defective and did not function safely, as advertised, or as intended by its design. Defendants' unfair, unlawful, and deceptive conduct in designing, manufacturing, marketing, selling, and leasing the Affected Vehicle with the Fuel Pump Defect has caused Plaintiff out-of-pocket loss, future attempted repairs, and diminished value of the Affected Vehicle.

122. Plaintiff uses the Affected Vehicle for personal and family uses. Prior to purchasing the Affected Vehicle, Plaintiff reviewed the Monroney sticker that Subaru placed on the window. The window sticker advertised the Affected Vehicle's various features (such as the price, specifications, gas mileage, equipment and warranty details, and crash test ratings), and Plaintiff relied on the advertisements contained within the window sticker when deciding to purchase the

Affected Vehicle. The Monroney sticker did not disclose that the Affected Vehicle possessed any defects.

123. Defendants never told Plaintiff about the Fuel Pump Defect, so Plaintiff purchased his Affected Vehicle on the reasonable, but mistaken, belief that his Affected Vehicle would be reliable and safe and would retain all of its operating characteristics throughout its useful life. Plaintiff specifically shopped for a Subaru vehicle because he believed Subaru's persistent advertising messaging that its vehicles were of high quality, were safe, and were reliable. None of the advertisements reviewed or representations received by Plaintiff contained any disclosure that the Affected Vehicle had a defect or the fact that Subaru would be unable to repair the defect. Had Defendants disclosed the Fuel Pump Defect, and the fact that Defendants would require Plaintiff to pay out-of-pocket costs, including repair costs, to put his vehicle into the condition it should have been in but for the defect and Defendants' insufficient "fix", Plaintiff would have received these disclosures, and he would not have purchased the Affected Vehicle or would have paid less for it.

25. Plaintiff Troy Perry

124. Plaintiff Troy Perry is a resident of the State of North Carolina, domiciled in the city of Denver, North Carolina. On or about September 1, 2019, Plaintiff purchased a new 2020 Subaru Ascent (for purposes of this section, the "Affected Vehicle") at Randy Marion Subaru (an authorized Subaru Dealership) in Mooresville, North Carolina.

125. Unknown to Plaintiff at the time the Affected Vehicle was purchased, it was equipped with a fuel delivery system that was defective and did not function safely, as advertised, or as intended by its design. Defendants' unfair, unlawful, and deceptive conduct in designing, manufacturing, marketing, selling, and leasing the Affected Vehicle with the Fuel Pump Defect

has caused Plaintiff out-of-pocket loss, future attempted repairs, and diminished value of the Affected Vehicle.

126. Plaintiff uses the Affected Vehicle for personal and family uses. Prior to purchasing the Affected Vehicle, Plaintiff reviewed the Monroney sticker that Subaru placed on the window. The window sticker advertised the Affected Vehicle's various features (such as the price, specifications, gas mileage, equipment and warranty details, and crash test ratings), and Plaintiff relied on the advertisements contained within the window sticker when deciding to purchase the Affected Vehicle. The Monroney sticker did not disclose that the Affected Vehicle possessed any defects.

127. Defendants never told Plaintiff about the Fuel Pump Defect, so Plaintiff purchased his Affected Vehicle on the reasonable, but mistaken, belief that his Affected Vehicle would be reliable and safe and would retain all of its operating characteristics throughout its useful life. Plaintiff specifically shopped for a Subaru vehicle because he believed Subaru's persistent advertising messaging that its vehicles were of high quality, were safe, and were reliable. None of the advertisements reviewed or representations received by Plaintiff contained any disclosure that the Affected Vehicle had a defect or the fact that Subaru would be unable to repair the defect. Had Defendants disclosed the Fuel Pump Defect, and the fact that Defendants would require Plaintiff to pay out-of-pocket costs, including repair costs, to put his vehicle into the condition it should have been in but for the defect and Defendants' insufficient "fix", Plaintiff would have received these disclosures, and he would not have purchased the Affected Vehicle or would have paid less for it.

26. Plaintiff Christine Schultz

128. Plaintiff Christine Schultz is a resident of the State of South Carolina, domiciled in the city of Charleston, South Carolina. On or about December 1, 2018, Plaintiff purchased a new

2019 Subaru Ascent (for purposes of this section, the “Affected Vehicle”) at Crews Subaru (an authorized Subaru Dealership) in North Charleston, South Carolina.

129. Unknown to Plaintiff at the time the Affected Vehicle was purchased, it was equipped with a fuel delivery system that was defective and did not function safely, as advertised, or as intended by its design. Defendants’ unfair, unlawful, and deceptive conduct in designing, manufacturing, marketing, selling, and leasing the Affected Vehicle with the Fuel Pump Defect has caused Plaintiff out-of-pocket loss, future attempted repairs, and diminished value of the Affected Vehicle.

130. Plaintiff uses the Affected Vehicle for personal and family uses. Prior to purchasing the Affected Vehicle, Plaintiff reviewed the Monroney sticker that Subaru placed on the window. The window sticker advertised the Affected Vehicle’s various features (such as the price, specifications, gas mileage, equipment and warranty details, and crash test ratings), and Plaintiff relied on the advertisements contained within the window sticker when deciding to purchase the Affected Vehicle. The Monroney sticker did not disclose that the Affected Vehicle possessed any defects.

131. Defendants never told Plaintiff about the Fuel Pump Defect, so Plaintiff purchased her Affected Vehicle on the reasonable, but mistaken, belief that his Affected Vehicle would be reliable and safe and would retain all of its operating characteristics throughout its useful life. Plaintiff specifically shopped for a Subaru vehicle because she believed Subaru’s persistent advertising messaging that its vehicles were of high quality, were safe, and were reliable. None of the advertisements reviewed or representations received by Plaintiff contained any disclosure that the Affected Vehicle had a defect or the fact that Subaru would be unable to repair the defect. Had Defendants disclosed the Fuel Pump Defect, and the fact that Defendants would require Plaintiff

to pay out-of-pocket costs, including repair costs, to put her vehicle into the condition it should have been in but for the defect and Defendants' insufficient "fix", Plaintiff would have received these disclosures, and he would not have purchased the Affected Vehicle or would have paid less for it.

27. Plaintiff Katherine Griffin

132. Plaintiff Katherine Griffin is a resident of the State of Alabama, domiciled in the city of Birmingham, Alabama. On or about February 1, 2018, Plaintiff purchased a new 2018 Subaru Outback (for purposes of this section, the "Affected Vehicle") at Montgomery Subaru (an authorized Subaru Dealership) in Montgomery, Alabama.

133. Unknown to Plaintiff at the time the Affected Vehicle was purchased, it was equipped with a fuel delivery system that was defective and did not function safely, as advertised, or as intended by its design. Defendants' unfair, unlawful, and deceptive conduct in designing, manufacturing, marketing, selling, and leasing the Affected Vehicle with the Fuel Pump Defect has caused Plaintiff out-of-pocket loss, future attempted repairs, and diminished value of the Affected Vehicle.

134. Plaintiff uses the Affected Vehicle for personal and family uses. Prior to purchasing the Affected Vehicle, Plaintiff reviewed the Monroney sticker that Subaru placed on the window. The window sticker advertised the Affected Vehicle's various features (such as the price, specifications, gas mileage, equipment and warranty details, and crash test ratings), and Plaintiff relied on the advertisements contained within the window sticker when deciding to purchase the Affected Vehicle. The Monroney sticker did not disclose that the Affected Vehicle possessed any defects.

135. Defendants never told Plaintiff about the Fuel Pump Defect, so Plaintiff purchased her Affected Vehicle on the reasonable, but mistaken, belief that her Affected Vehicle would be

reliable and safe and would retain all of its operating characteristics throughout its useful life. Plaintiff specifically shopped for a Subaru vehicle because she believed Subaru's persistent advertising messaging that its vehicles were of high quality, were safe, and were reliable. None of the advertisements reviewed or representations received by Plaintiff contained any disclosure that the Affected Vehicle had a defect or the fact that Subaru would be unable to repair the defect. Had Defendants disclosed the Fuel Pump Defect, and the fact that Defendants would require Plaintiff to pay out-of-pocket costs, including repair costs, to put her vehicle into the condition it should have been in but for the defect and Defendants' insufficient "fix", Plaintiff would have received these disclosures, and she would not have purchased the Affected Vehicle or would have paid less for it.

28. Plaintiff Janet Oakley

136. Plaintiff Janet Oakley is a resident of the State of Alabama, domiciled in the city of Wetumpka, Alabama. On or about September 1, 2017, Plaintiff purchased a new 2017 Subaru Outback (for purposes of this section, the "Affected Vehicle") at Montgomery Subaru (an authorized Subaru Dealership) in Montgomery, Alabama.

137. Unknown to Plaintiff at the time the Affected Vehicle was purchased, it was equipped with a fuel delivery system that was defective and did not function safely, as advertised, or as intended by its design. Defendants' unfair, unlawful, and deceptive conduct in designing, manufacturing, marketing, selling, and leasing the Affected Vehicle with the Fuel Pump Defect has caused Plaintiff out-of-pocket loss, future attempted repairs, and diminished value of the Affected Vehicle.

138. Plaintiff uses the Affected Vehicle for personal and family uses. Prior to purchasing the Affected Vehicle, Plaintiff reviewed the Monroney sticker that Subaru placed on the window. The window sticker advertised the Affected Vehicle's various features (such as the price,

specifications, gas mileage, equipment and warranty details, and crash test ratings), and Plaintiff relied on the advertisements contained within the window sticker when deciding to purchase the Affected Vehicle. The Monroneys sticker did not disclose that the Affected Vehicle possessed any defects.

139. Plaintiff's Affected Vehicle has also experienced the symptoms associated with the Fuel Pump Defect. Specifically, when operating her vehicle under normal and intended circumstances, Plaintiff Oakley experiences poor throttle response and weak acceleration when depressing her accelerator pedal. Plaintiff experiences the Fuel Pump Defect on a weekly basis.

140. Defendants never told Plaintiff about the Fuel Pump Defect, so Plaintiff purchased her Affected Vehicle on the reasonable, but mistaken, belief that her Affected Vehicle would be reliable and safe and would retain all of its operating characteristics throughout its useful life. Plaintiff specifically shopped for a Subaru vehicle because she believed Subaru's persistent advertising messaging that its vehicles were of high quality, were safe, and were reliable. None of the advertisements reviewed or representations received by Plaintiff contained any disclosure that the Affected Vehicle had a defect or the fact that Subaru would be unable to repair the defect. Had Defendants disclosed the Fuel Pump Defect, and the fact that Defendants would require Plaintiff to pay out-of-pocket costs, including repair costs, to put her vehicle into the condition it should have been in but for the defect and Defendants' insufficient "fix", Plaintiff would have received these disclosures, and she would not have purchased the Affected Vehicle or would have paid less for it.

29. Plaintiff Adam Whitley

141. Plaintiff Adam Whitley is a resident of the State of Alabama, domiciled in the city of Montgomery, Alabama. On or about February 1, 2017, Plaintiff purchased a new 2017 Subaru

Outback (for purposes of this section, the “Affected Vehicle”) at Montgomery Subaru (an authorized Subaru Dealership) in Montgomery, Alabama.

142. Unknown to Plaintiff at the time the Affected Vehicle was purchased, it was equipped with a fuel delivery system that was defective and did not function safely, as advertised, or as intended by its design. Defendants’ unfair, unlawful, and deceptive conduct in designing, manufacturing, marketing, selling, and leasing the Affected Vehicle with the Fuel Pump Defect has caused Plaintiff out-of-pocket loss, future attempted repairs, and diminished value of the Affected Vehicle.

143. Plaintiff uses the Affected Vehicle for personal and family uses. Prior to purchasing the Affected Vehicle, Plaintiff reviewed the Monroney sticker that Subaru placed on the window. The window sticker advertised the Affected Vehicle’s various features (such as the price, specifications, gas mileage, equipment and warranty details, and crash test ratings), and Plaintiff relied on the advertisements contained within the window sticker when deciding to purchase the Affected Vehicle. The Monroney sticker did not disclose that the Affected Vehicle possessed any defects.

144. Plaintiff’s Affected Vehicle has also experienced the symptoms associated with the Fuel Pump Defect. Specifically, when operating his vehicle under normal and intended circumstances, Plaintiff experiences poor throttle response and weak acceleration when depressing the accelerator pedal. On September 14, 2020, Plaintiff was on the way to his office when he entered into stop-and-go traffic, forcing him to slow down but never come to a complete stop. Plaintiff attempted to accelerate his vehicle when the traffic began moving along, but the vehicle lost power and almost shut completely off. Plaintiff then let off the accelerator pedal and attempted to accelerate again, eventually regaining power.

145. Defendants never told Plaintiff about the Fuel Pump Defect, so Plaintiff purchased his Affected Vehicle on the reasonable, but mistaken, belief that his Affected Vehicle would be reliable and safe and would retain all of its operating characteristics throughout its useful life. Plaintiff specifically shopped for a Subaru vehicle because he believed Subaru's persistent advertising messaging that its vehicles were of high quality, were safe, and were reliable. None of the advertisements reviewed or representations received by Plaintiff contained any disclosure that the Affected Vehicle had a defect or the fact that Subaru would be unable to repair the defect. Had Defendants disclosed the Fuel Pump Defect, and the fact that Defendants would require Plaintiff to pay out-of-pocket costs, including repair costs, to put his vehicle into the condition it should have been in but for the defect and Defendants' insufficient "fix", Plaintiff would have received these disclosures, and he would not have purchased the Affected Vehicle or would have paid less for it.

30. Plaintiff Chiara Bancod-Hile

146. Plaintiff Chiara Bancod-Hile is a resident of the State of California, domiciled in the city of Ontario, California. On or about March 1, 2015, Plaintiff purchased a new 2015 Subaru Imprezza (for purposes of this section, the "Affected Vehicle") at Puente Hills Subaru (an authorized Subaru Dealership) in Innisfree, California.

147. Unknown to Plaintiff at the time the Affected Vehicle was purchased, it was equipped with a fuel delivery system that was defective and did not function safely, as advertised, or as intended by its design. Defendants' unfair, unlawful, and deceptive conduct in designing, manufacturing, marketing, selling, and leasing the Affected Vehicle with the Fuel Pump Defect has caused Plaintiff out-of-pocket loss, future attempted repairs, and diminished value of the Affected Vehicle.

148. Plaintiff uses the Affected Vehicle for personal and family uses. Prior to purchasing the Affected Vehicle, Plaintiff reviewed the Monroney sticker that Subaru placed on the window. The window sticker advertised the Affected Vehicle's various features (such as the price, specifications, gas mileage, equipment and warranty details, and crash test ratings), and Plaintiff relied on the advertisements contained within the window sticker when deciding to purchase the Affected Vehicle. The Monroney sticker did not disclose that the Affected Vehicle possessed any defects.

149. Plaintiff's Affected Vehicle has also experienced the symptoms associated with the Fuel Pump Defect. Specifically, in late 2017, while operating her vehicle under intended and foreseeable circumstances, Plaintiff's vehicle experienced hesitated acceleration when the accelerator was depressed. Plaintiff presented her vehicle to the Subaru dealership with complaints of hesitated acceleration; however, the dealership claimed Plaintiff's vehicle was operating as designed. Plaintiff was offered a loaner vehicle while her Subaru was being inspected. Plaintiff's Vehicle was not repaired.

150. Defendants never told Plaintiff about the Fuel Pump Defect, so Plaintiff purchased her Affected Vehicle on the reasonable, but mistaken, belief that her Affected Vehicle would be reliable and safe and would retain all of its operating characteristics throughout its useful life. Plaintiff specifically shopped for a Subaru vehicle because she believed Subaru's persistent advertising messaging that its vehicles were of high quality, were safe, and were reliable. None of the advertisements reviewed or representations received by Plaintiff contained any disclosure that the Affected Vehicle had a defect or the fact that Subaru would be unable to repair the defect. Had Defendants disclosed the Fuel Pump Defect, and the fact that Defendants would require Plaintiff to pay out-of-pocket costs, including repair costs, to put her vehicle into the condition it should

have been in but for the defect and Defendants' insufficient "fix", Plaintiff would have received these disclosures, and she would not have purchased the Affected Vehicle or would have paid less for it.

31. Plaintiff Roman Anderson

151. Plaintiff Roman Anderson is a resident of the State of Hawaii, domiciled in the city of Laupāhoehoe, Hawaii. In the spring of 2019, Plaintiff purchased a certified pre-owned Subaru Outback (for purposes of this section, the "Affected Vehicle") at Big Island Motors (an authorized Subaru Dealership) in Hilo, Hawaii.

152. Unknown to Plaintiff at the time the Affected Vehicle was purchased, it was equipped with a fuel delivery system that was defective and did not function safely, as advertised, or as intended by its design. Defendants' unfair, unlawful, and deceptive conduct in designing, manufacturing, marketing, selling, and leasing the Affected Vehicle with the Fuel Pump Defect has caused Plaintiff out-of-pocket loss, future attempted repairs, and diminished value of the Affected Vehicle.

153. Plaintiff uses the Affected Vehicle for personal and family uses. Prior to purchasing the Affected Vehicle, Plaintiff reviewed the Monroney sticker that Subaru placed on the window. The window sticker advertised the Affected Vehicle's various features (such as the price, specifications, gas mileage, equipment and warranty details, and crash test ratings), and Plaintiff relied on the advertisements contained within the window sticker when deciding to purchase the Affected Vehicle. The Monroney sticker did not disclose that the Affected Vehicle possessed any defects.

154. Plaintiff's Affected Vehicle has also experienced the symptoms associated with the Fuel Pump Defect. Specifically, in or around May 2020, Plaintiff's Affected Vehicle experienced

engine no start twice in one week. He was able to restart the Vehicle but only after multiple attempts. In approximately November 2019, his Vehicle stalled as he waited at a stop sign.

155. Defendants never told Plaintiff about the Fuel Pump Defect, so Plaintiff purchased his Affected Vehicle on the reasonable, but mistaken, belief that his Affected Vehicle would be reliable and safe and would retain all of its operating characteristics throughout its useful life. Plaintiff specifically shopped for a Subaru vehicle because he believed Subaru's persistent advertising messaging that its vehicles were of high quality, were safe, and were reliable. None of the advertisements reviewed or representations received by Plaintiff contained any disclosure that the Affected Vehicle had a defect or the fact that Subaru would be unable to repair the defect. Had Defendants disclosed the Fuel Pump Defect, and the fact that Defendants would require Plaintiff to pay out-of-pocket costs, including repair costs, to put his vehicle into the condition it should have been in but for the defect and Defendants' insufficient "fix", Plaintiff would have received these disclosures, and he would not have purchased the Affected Vehicle or would have paid less for it.

32. Plaintiff David Sroelov

156. Plaintiff David Sroelov is a resident of the State of Nevada, domiciled in the city of Henderson, Nevada. On or about June 1, 2019, Plaintiff purchased a new 2019 Subaru Outback (for purposes of this section, the "Affected Vehicle") at Subaru of Las Vegas (an authorized Subaru Dealership) in Las Vegas, Nevada.

157. Unknown to Plaintiff at the time the Affected Vehicle was purchased, it was equipped with a fuel delivery system that was defective and did not function safely, as advertised, or as intended by its design. Defendants' unfair, unlawful, and deceptive conduct in designing, manufacturing, marketing, selling, and leasing the Affected Vehicle with the Fuel Pump Defect

has caused Plaintiff out-of-pocket loss, future attempted repairs, and diminished value of the Affected Vehicle.

158. Plaintiff uses the Affected Vehicle for personal and family uses. Prior to purchasing the Affected Vehicle, Plaintiff reviewed the Monroney sticker that Subaru placed on the window. The window sticker advertised the Affected Vehicle's various features (such as the price, specifications, gas mileage, equipment and warranty details, and crash test ratings), and Plaintiff relied on the advertisements contained within the window sticker when deciding to purchase the Affected Vehicle. The Monroney sticker did not disclose that the Affected Vehicle possessed any defects.

159. Plaintiff's Affected Vehicle has also experienced the symptoms associated with the Fuel Pump Defect. Specifically, soon after purchasing his Vehicle, in September 2019, while operating his vehicle under intended and foreseeable circumstances, Plaintiff's Vehicle experienced hesitated acceleration when the accelerator was depressed and warning lights illuminated on his vehicle's dashboard. He reported the incident to the Subaru dealership, which replaced the fuel pump under warranty in September 2019.

160. Defendants never told Plaintiff about the Fuel Pump Defect, so Plaintiff purchased his Affected Vehicle on the reasonable, but mistaken, belief that his Affected Vehicle would be reliable and safe and would retain all of its operating characteristics throughout its useful life. Plaintiff specifically shopped for a Subaru vehicle because he believed Subaru's persistent advertising messaging that its vehicles were of high quality, were safe, and were reliable. None of the advertisements reviewed or representations received by Plaintiff contained any disclosure that the Affected Vehicle had a defect or the fact that Subaru would be unable to repair the defect. Had Defendants disclosed the Fuel Pump Defect, and the fact that Defendants would require Plaintiff

to pay out-of-pocket costs, including repair costs, to put his vehicle into the condition it should have been in but for the defect and Defendants' insufficient "fix", Plaintiff would have received these disclosures, and he would not have purchased the Affected Vehicle or would have paid less for it.

33. Plaintiff Robert Karrat

161. Plaintiff Robert Karrat is a resident of the State of Connecticut, domiciled in the city of Danbury, Connecticut. On or about February 1, 2018, Plaintiff purchased a used 2013 Subaru Outback (for purposes of this section, the "Affected Vehicle") at New Rochelle Chevrolet in New Rochelle, New York.

162. Unknown to Plaintiff at the time the Affected Vehicle was purchased, it was equipped with a fuel delivery system that was defective and did not function safely, as advertised, or as intended by its design. Defendants' unfair, unlawful, and deceptive conduct in designing, manufacturing, marketing, selling, and leasing the Affected Vehicle with the Fuel Pump Defect has caused Plaintiff out-of-pocket loss, future attempted repairs, and diminished value of the Affected Vehicle.

163. Plaintiff uses the Affected Vehicle for personal and family uses. Prior to purchasing the Affected Vehicle, Plaintiff reviewed the Monroney sticker that Subaru placed on the window. The window sticker advertised the Affected Vehicle's various features (such as the price, specifications, gas mileage, equipment and warranty details, and crash test ratings), and Plaintiff relied on the advertisements contained within the window sticker when deciding to purchase the Affected Vehicle. The Monroney sticker did not disclose that the Affected Vehicle possessed any defects.

164. Plaintiff's Affected Vehicle has also experienced symptoms associated with the Fuel Pump Defect. Specifically, in April 2020, while operating his Vehicle under intended and

foreseeable circumstances, Plaintiff's Vehicle experienced hesitated acceleration and stalled. Plaintiff's Vehicle continues to experience symptoms associated with the Fuel Pump Defect to this day.

165. Defendants never told Plaintiff about the Fuel Pump Defect, so Plaintiff purchased his Affected Vehicle on the reasonable, but mistaken, belief that his Affected Vehicle would be reliable and safe and would retain all of its operating characteristics throughout its useful life. Plaintiff specifically shopped for a Subaru vehicle because he believed Subaru's persistent advertising messaging that its vehicles were of high quality, were safe, and were reliable. None of the advertisements reviewed or representations received by Plaintiff contained any disclosure that the Affected Vehicle had a defect or the fact that Subaru would be unable to repair the defect. Had Defendants disclosed the Fuel Pump Defect, and the fact that Defendants would require Plaintiff to pay out-of-pocket costs, including repair costs, to put his vehicle into the condition it should have been in but for the defect and Defendants' insufficient "fix", Plaintiff would have received these disclosures, and he would not have purchased the Affected Vehicle or would have paid less for it.

34. Plaintiff Mark Gardener

166. Plaintiff Mark Gardener is a resident of the State of Texas, domiciled in the city of Dallas, Texas. On or about 2017, Plaintiff leased a new 2017 Subaru Legacy (for purposes of this section, the "Affected Vehicle") at Sewell Subaru of Dallas (an authorized Subaru Dealership) in Dallas, Texas.

167. Unknown to Plaintiff at the time the Affected Vehicle was purchased, it was equipped with a fuel delivery system that was defective and did not function safely, as advertised, or as intended by its design. Defendants' unfair, unlawful, and deceptive conduct in designing, manufacturing, marketing, selling, and leasing the Affected Vehicle with the Fuel Pump Defect

has caused Plaintiff out-of-pocket loss, future attempted repairs, and diminished value of the Affected Vehicle.

168. Plaintiff uses the Affected Vehicle for personal and family uses. Prior to purchasing the Affected Vehicle, Plaintiff reviewed the Monroney sticker that Subaru placed on the window. The window sticker advertised the Affected Vehicle's various features (such as the price, specifications, gas mileage, equipment and warranty details, and crash test ratings), and Plaintiff relied on the advertisements contained within the window sticker when deciding to purchase the Affected Vehicle. The Monroney sticker did not disclose that the Affected Vehicle possessed any defects.

169. Plaintiff's Affected Vehicle has also experienced symptoms associated with the Fuel Pump Defect. Beginning in 2017, immediately after leasing his Vehicle, Plaintiff, while operating his Vehicle under intended and foreseeable circumstances, experienced hesitated acceleration and trouble cranking up his vehicle. Plaintiff's Vehicle continues to experience symptoms associated with the Fuel Pump Defect to this day. Plaintiff contacted the dealer, who stated that nothing was wrong with the vehicle, and no repairs were made.

170. Defendants never told Plaintiff about the Fuel Pump Defect, so Plaintiff purchased his Affected Vehicle on the reasonable, but mistaken, belief that his Affected Vehicle would be reliable and safe and would retain all of its operating characteristics throughout its useful life. Plaintiff specifically shopped for a Subaru vehicle because he believed Subaru's persistent advertising messaging that its vehicles were of high quality, were safe, and were reliable. None of the advertisements reviewed or representations received by Plaintiff contained any disclosure that the Affected Vehicle had a defect or the fact that Subaru would be unable to repair the defect. Had Defendants disclosed the Fuel Pump Defect, and the fact that Defendants would require Plaintiff

to pay out-of-pocket costs, including repair costs, to put his vehicle into the condition it should have been in but for the defect and Defendants' insufficient "fix", Plaintiff would have received these disclosures, and he would not have purchased the Affected Vehicle or would have paid less for it.

B. Defendants

1. Subaru Corporation

171. Defendant Subaru Corporation is a Japanese corporation with its principal place of business in Tokyo, Japan, in the Shibuya province, and is the parent company of Defendant Subaru of America.

172. Subaru Corporation has purposefully availed itself of this jurisdiction by designing, manufacturing, marketing, distributing, and selling the Affected Vehicles in New Jersey and throughout the United States.

2. Subaru of America, Inc.

173. Defendant Subaru of America, Inc. ("SOA," and together with Subaru Corporation, "Subaru") is a New Jersey corporation with its principal place of business in Camden, New Jersey.

174. SOA is a wholly owned subsidiary of Subaru Corporation and serves as Subaru Corporation's sales and marketing agent in the United States. SOA is responsible for marketing, selling, distributing, and servicing the Affected Vehicles in the United States.

175. In this Complaint, when reference is made to any act, deed or conduct of Subaru the allegation means that the Subaru Defendants engaged in the act, deed or conduct by or through one or more of their officers, directors, agents, employees, or representatives who was actively engaged in the management, direction, control, or transaction of the ordinary business and affairs of the defendant.

176. Subaru sells cars in part via communications that it authorized its dealers to make about Subaru vehicles, including the Defective Vehicles discussed herein. This includes authorizing Subaru dealers to distribute brochures and other marketing and promotional material. Subaru, through its authorized dealers, has had the opportunity to disclose all material facts relating to the Defective Vehicles.

177. Authorized Subaru dealers are Subaru's agents, such that an opportunity to receive information from an authorized Subaru dealership is an opportunity to receive information directly from Subaru itself. *See Daniel v. Ford Motor Co.*, 806 F.3d 1217, 1226 (9th Cir. 2015). This agency relationship is established by the fact that, among other things: Subaru's logo is displayed at authorized dealerships; Subaru issues technical bulletins and service instructions to dealerships detailing potential vehicle problems, and also relies on them to push software updates to customers' vehicles; Subaru distributes various advertising and promotional material to its dealerships, including brochures, booklets, and pamphlets; and under the terms of its express warranty, Subaru requires its customers to return to its authorized dealerships to perform warranty repairs.¹⁵

3. Denso Corporation

178. Defendant Denso Corporation ("DC") is a Japanese corporation located at 1-1, Showa-cho, Karlya, Alchi 448-9661, Japan. DC is the parent company of Denso International of America, Inc. ("DIAM").

¹⁵ *See* 2019 Warranty, available at <https://www.subaru.com/owners/vehicle-resources/manuals.html?modelCode=2019-ASC-KCA> (last visited July 7, 2020). The 2019 Warranty states that "[a]ny and all repairs must be performed by an Authorized SUBARU Retailer located in the United States."

179. DIAM is a wholly owned subsidiary of DC. DIAM acts for the benefit and at the discretion of DC.

180. DC itself, and through DIAM and its various subsidiaries and agents, designed, engineered, tested, and validated the Fuel Pump that is equipped in Subaru vehicles sold/leased in the United States, including in Plaintiffs' states.

4. Denso International of America, Inc.

181. Defendant Denso International America, Inc. ("DIAM") is incorporated in Delaware and has its principal place of business at 2477 Denso Drive Southfield, Michigan 48033. DIAM is a holding company of sales, manufacturing, engineering, and research and development subsidiaries of Denso Corporation located in the United States. DIAM is in the business of designing, engineering, testing, validating, manufacturing, selling, among other things, fuel pumps throughout the United States, including within New Jersey.

182. DIAM is Denso's North American regional headquarters and parent company for its North American operations, including design and production engineering, technical support, sales and finance.

183. DIAM, through its various entities and on behalf of DC, designed, engineered, tested, and validated the Fuel Pump that is equipped in Subaru Vehicles across the United States, including in Plaintiffs' states.

III. JURISDICTION

184. This Court has subject matter jurisdiction pursuant to the Class Action Fairness Act of 2005, 28 U.S.C. § 1332(d), because at least one Class member is of diverse citizenship from one defendant, there are more than 100 Class members nationwide, and the aggregate amount in controversy exceeds \$5,000,000 and minimal diversity exists.

185. Subject matter jurisdiction is also proper in this Court pursuant to 28 U.S.C. § 1331 because Plaintiffs' Magnuson-Moss Warranty Act claim arises under federal law, and this Court has supplemental subject matter jurisdiction over Plaintiffs' state law claims under 28 U.S.C. § 1367.

Subaru Defendants

186. This Court has personal jurisdiction over the Subaru Defendants because SOA operates its headquarters and principal place of business in Camden, New Jersey, located in this District. Both Subaru Defendants have purposefully availed themselves of the privileges, benefits and protections of this District by continuously and systematically conducting substantial business in this District. As detailed below, Subaru, itself and/or through its subsidiaries or agents, transacts business within the State of New Jersey and/or contracts anywhere to supply goods or services in New Jersey while obtaining substantial revenue in New Jersey, including by marketing and selling the Affected Vehicles and other products in New Jersey and providing repair services related to the Recall and the Affected Vehicles, and has injured Plaintiffs and Class Members in New Jersey.

Denso Defendants

187. This Court has personal jurisdiction over Denso because, as described below, both Denso Defendants have purposefully availed themselves of the privileges, benefits and protections of this District by continuously and systematically conducting substantial business in this District. As detailed below, Denso, itself and/or through its subsidiaries or agents, transacts business within the State of New Jersey and/or contracts anywhere to supply goods or services in New Jersey while obtaining substantial revenue in New Jersey, including by manufacturing, marketing, and selling the defective fuel pump and other products in New Jersey, and has injured Plaintiffs and Class Members in New Jersey.

188. Denso, itself and/or through its subsidiaries, entered into an agreement with Subaru for the sale of its Fuel Pumps, which it knew, and intended, would be installed in the Class Vehicles and sold in New Jersey.

189. Denso, itself and/or through its subsidiaries and/or agents, also independently sells and distributes its fuel pumps in New Jersey to Subaru dealerships, repair shops, and automotive parts stores to be used as service replacement parts.

190. Denso, itself and/or through its subsidiaries or agents, maintains an interactive website that is accessible in New Jersey and from which it solicits business in New Jersey, and markets its brand and products in New Jersey.

191. Denso, itself and/or through its subsidiaries or agents, disseminated statements that omitted material facts, made material misrepresentations and/or misleading statements, which damaged Plaintiffs and Class Members in New Jersey and elsewhere, as alleged herein.

192. Denso has derived substantial revenue from New Jersey. On its website, Denso states it does business at over 41 locations throughout the United States, holds 1,900 U.S. Patents, employs over 17,700 persons, and makes \$10.9 billion in annual sales, including from New Jersey.¹⁶

193. Denso, by and through its subsidiaries and/or agents, is registered to do business in New Jersey. Specifically, Denso International America, Inc., Denso Sales California, Inc., and Denso Personnel Service America, Inc., are all registered to do business in New Jersey and have offices in New Jersey.

¹⁶ <https://www.denso.com/us-ca/en/about-us/at-a-glance/> (last visited January 18, 2021).

194. Hundreds of thousands of New Jersey citizens are operating vehicles equipped with Denso made fuel pumps, and Denso has derived millions of dollars in revenue from the sale of its fuel pumps in New Jersey.

195. Denso, itself and/or through its subsidiaries or agents, purposefully availed itself of the privileges of doing business in New Jersey.

196. Denso, itself and/or through its subsidiaries or agents, has sufficient contacts with the State of New Jersey such that exercising jurisdiction over Denso is reasonable and comports with due process.

IV. VENUE

197. Venue is proper pursuant to 28 U.S.C. § 1391(a) & (b) because a substantial part of the events or omissions giving rise to the claims occurred in this District. Subaru licenses authorized dealers in this District, it advertises in this District, and it profits from its activities conducted within this District.

V. FACTUAL ALLEGATIONS

A. The Operation of a Low Pressure Fuel Pump

198. The Subaru fuel system relies on two fuel pumps to supply fuel to the engine: a low pressure fuel pump (in-tank) and high pressure fuel pump (in-line). Fuel pumps serve a critical role in the function of combustion engines. In simple terms, the fuel pump lifts gasoline out of the fuel tank and sends it to the engine where it is injected into the combustion chamber and ignited, driving the pistons and creating propulsion. Denso explains the role of the electric fuel pump as “deliver[ing] fuel from the tank to the engine, under high pressure, depending on the vehicle

application's specific requirements. The fuel is transported to fuel injectors, which spray the fuel into the engine cylinders."¹⁷

199. The low-pressure fuel pump assembly is mounted inside of the fuel tank. The fuel pump assembly consists of a fuel intake strainer at one end and a fuel output line at the other. At the heart of the fuel pump assembly is an electric motor with a plastic impeller attached to a rotating shaft. The impeller is a plastic disk that rotates and draws in fuel and pushes it up through the pump.¹⁸ The impeller is a rotating component equipped with vanes—or blades—that, when spun, creates negative pressure which lifts the gasoline out of the fuel tank and sends it to the engine. Protruding from the side of the fuel pump assembly is a fuel level float and a fuel level sender. Figure 1 illustrates the parts of the Fuel Pump assembly. Figure 2 illustrates the internal components of the Denso fuel pump's electric motor.

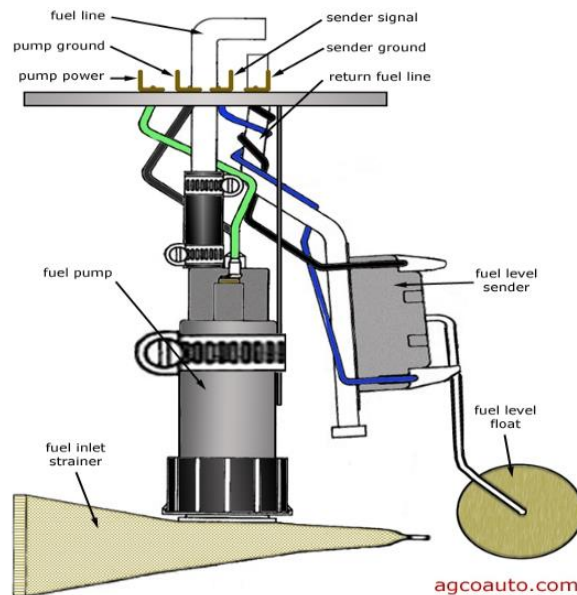

¹⁷ <https://www.denso-am.eu/products/automotive-aftermarket/ignition/fuel-pumps/> (last visited January 18, 2021).

¹⁸ <https://www.denso-am.co.uk/products/automotive-aftermarket/ems-lambda-sensor/fuel-pumps/how-they-work/> (last visited January 18, 2021).

Figure 1 Fuel Pump Assembly Diagram¹⁹

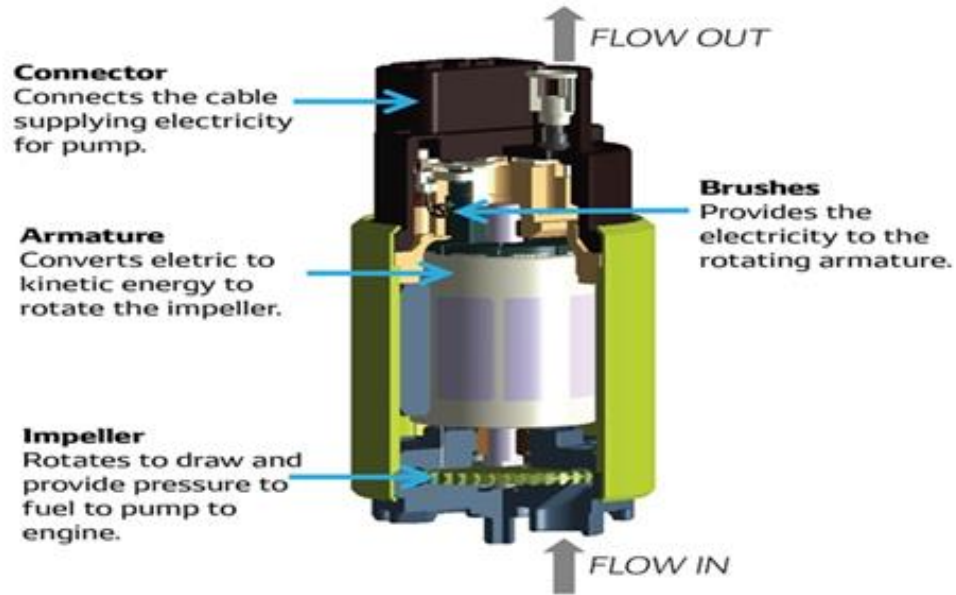

Figure 2 Electric Motor Internal Components²⁰

200. As the electric motor rotates, the impeller spins generating negative pressure. The negative pressure pulls fuel into the pump housing where it passes through the electric motor assembly and exits through the output, into the fuel line and forward to the fuel filter. After exiting the fuel filter, the fuel flow is accelerated via a high-pressure pump which delivers pressurized fuel to injectors mounted in the engine. Denso describes the operation of its in-tank fuel pump as “[w]hen the impeller of an in-tank [f]uel [p]ump rotates, the blade moves around the impeller, creating a swirling motion inside the pump to deliver fuel. The fuel then passes around the motor,

¹⁹ http://www.agcoauto.com/content/news/p2_articleid/195 (last visited January, 2021).

²⁰ https://aftermarket.denso.com.sg/product_info/?cat_id=194 (last visited January 18, 2021).

forcing the check valve upwards to supply fuel to the fuel pipe.”²¹ Figures 3 and 4, below, illustrate this sequence.

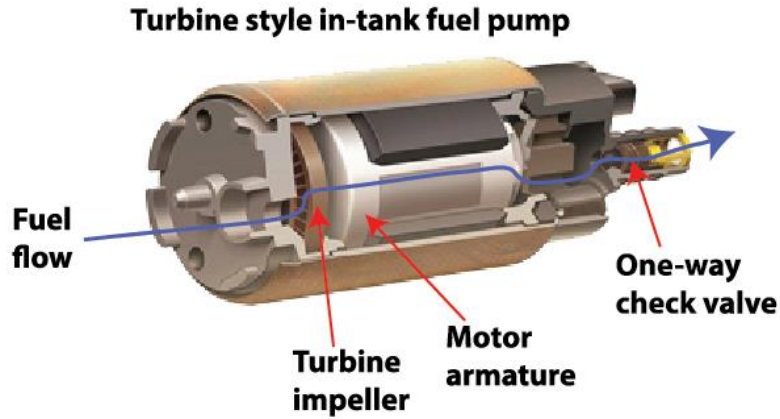

*Figure 3 Fuel Pump Sequence*²²

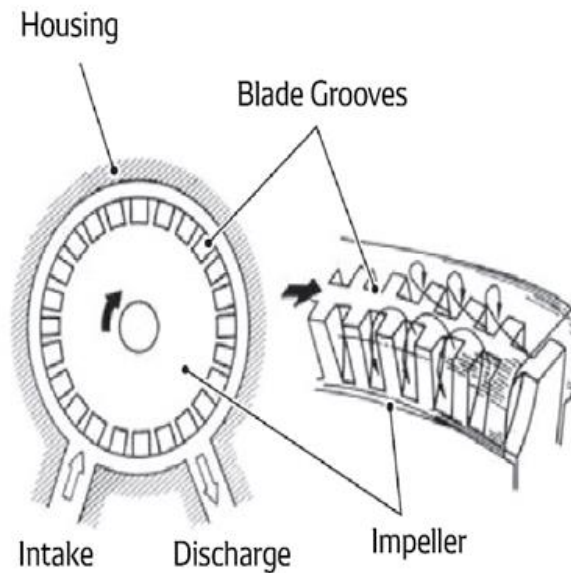

*Figure 4 Impeller Rotation Operation*²³

²¹ <https://www.denso-am.eu/media/966284/dems180001mm-lr.pdf> (last visited January 18, 2021).

²² <https://www.autoplusdubai.net/blog/fuel-pumps-common-causes-and-how-to-identify-it/> (last visited January 18, 2021).

²³ https://aftermarket.denso.com.sg/product_info/?cat_id=194 (last visited January 18, 2021)

201. At all times, by design, the fuel pump assembly and all its components are exposed to gasoline within the tank. Fuel pumps are designed to survive the harsh environment for at least 200,000 miles.²⁴ Denso claims its fuel pumps “offer more than triple the lifetime”²⁵ Denso touts the “Denso Difference,” claiming its auto parts are made with “Precision engineering. Advanced design. The highest OEM quality.”²⁶ It tells customers “[b]ecause DENSO’s rigorous manufacturing and testing process produces each fuel pump, you can be sure it meets our high standards for fit and performance.”

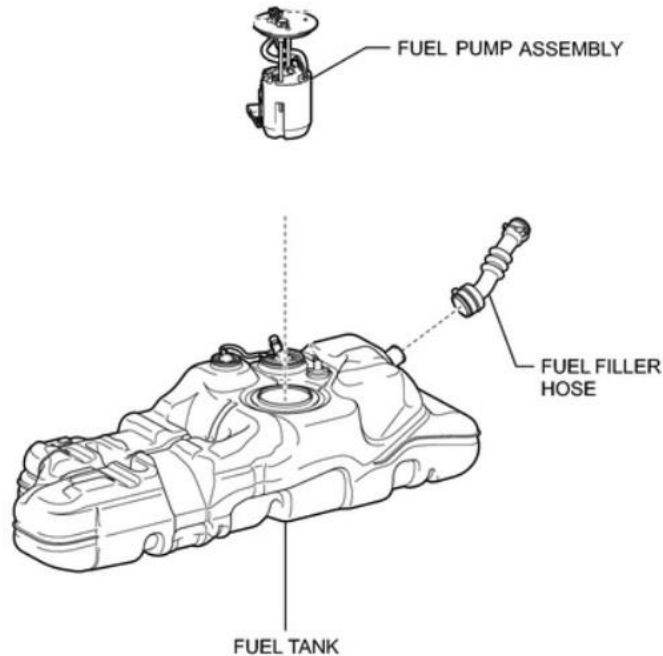

Figure 5

²⁴ <https://www.autoblog.com/2015/11/24/how-long-does-a-fuel-pump-usually-last/> (last visited January 18, 2021).

²⁵ <https://densoautoparts.com/fuel-pumps.aspx> (last visited January 18, 2021).

²⁶ <https://www.denso-am.eu/media/966284/dems180001mm-lr.pdf> (last visited January 18, 2021).

B. The Defective Fuel Delivery Systems

202. As a key component to the safe and reliable operation of a vehicle, a fuel pump must be designed to operate over the life of a vehicle. Yet, as Defendants admit through their recalls, the defective fuel pumps contain an impeller that can deform in regular operation of a vehicle – the subject fuel pumps contain an impeller that can deform due to excessive fuel absorption.²⁷ The fuel pump’s impeller’s material is unsuitable for its environment due to its excessive fuel absorption propensity, which causes swelling and premature and unexpected fuel pump failure.²⁸

203. Plaintiffs’ Expert’s research to date indicates that the Denso impeller uses an unsuitable material for its intended use. The impeller’s material has an inferior long-term dimensional stability (it deforms, swells and changes shape), resulting in premature and unexpected failure due to component distortion and the resultant swelling induced friction.

204. The impeller’s material has inadequate heat resistance, potentially resulting in dimensional distortion and loss of structural integrity when exposed to high temperatures or repeated temperature cycling (i.e., the intended and repeated temperature changes of operation).

205. The impeller’s material is also highly porous, which may lead not only to absorption of gasoline, but also fuel contaminants may become lodged in the impeller’s pores, leading to Fuel Pump failure.

206. Plastics absorb liquids, typically. However, the degree of absorption varies depending on the type of plastic and its environmental conditions. When plastics absorb liquid, such as gasoline, the plastic pieces’ intended dimensions change. Therefore, manufacturers like

²⁷ Compare Exhibits A-B, with Exhibit C.

²⁸ See Exhibits A at 1-2.

Denso and Subaru must adequately design and validate plastic materials exposed to liquids to ensure that they remain dimensionally stable.²⁹ Here, Subaru and Denso clearly failed to do that with respect to the fuel pumps in the Affected Vehicles.

207. Subaru hypothesizes that other factors such as excessive solvent exposure, gasoline formulas and contaminants can cause or are the source of the Fuel Pump Defect. But Subaru ignores what Denso admits, and Plaintiffs' Expert's research to date indicates, to be the underlying cause: The impeller's lower density material is susceptible to fuel absorption and deformation.³⁰

208. Moreover, according to Plaintiffs' Expert's research to date, Denso's further hypothesis that lower surface strength of the impeller contributes to the Fuel Pump Defect is an obvious and expected correlation rather than a separate issue. Notably, it is typical and expected for a low-density material to exhibit lower surface strength when compared to a higher density material. It is also expected that low density materials would have higher porosity and absorption propensity compared to higher density materials.

209. Subaru and Denso both admit the impeller was poorly designed to the point that it cannot remain dimensionally stable under its intended conditions. Specifically, Subaru admitted in its Recall Report that the impeller can deform to a point that it interferes with the fuel pump body and will therefore become inoperative which could lead to engine failure and increase the risk for a crash.³¹ Moreover, Denso admitted in the Denso Recalls that the impeller "may become deformed" and cause the Fuel Pump to fail and become inoperable.³²

²⁹ See generally <https://www.ensingerplastics.com/en-us/shapes/plastic-material-selection/dimensionally-stable> (last visited January 18, 2021).

³⁰ Exhibits A and B.

³¹ Exhibit C.

³² Exhibit A.

210. The Fuel Pump Defect manifests from the moment the fuel pump is installed in the fuel tank and exposed to gasoline. Once exposed to gasoline, the impeller begins to absorb fuel, swell, and deform.

211. The fuel pump and/or the fuel pump's impeller was not designed and/or manufactured with the necessary robustness to operate safely under normal operating conditions.

212. At the time the fuel pumps were designed, engineered, tested, validated, manufactured, and placed in the stream of commerce by Defendants, Defendants were aware of, and had access to, reasonable alternative designs. Such designs would mitigate or eliminate the Fuel Pump Defect.

213. For example, Defendants could have mitigated or eliminated the Fuel Pump Defect by using different designs and/or materials where:

- a. The impeller was not fuel permeable under intended and foreseeable conditions;
- b. The impeller would not deform when exposed to operating temperatures under intended and foreseeable conditions;
- c. The impeller would not prematurely age under intended and foreseeable conditions;
- d. The impeller would not lose its dimensional stability under intended and foreseeable conditions;
- e. The impeller would not contact the fuel pump body under intended and foreseeable conditions; and/or
- f. The fuel pump would not overheat under intended and foreseeable conditions.

214. Defendants were aware of the Fuel Pump Defect years before any recalls were issued. As early as 2015, Denso had recognized that the low-pressure fuel pumps that it supplied to Subaru and other manufacturers were prone to failure. In a patent application filed in 2016, Denso admitted that the composite (plastic) impellers in its low-pressure fuel pumps “may be swelled due to the fuel and water contained in the fuel, [and] therefore a rotation of the impeller may be stopped when the impeller is swelled and comes in contact with the [fuel pump] housing.”³³ The defect described by the patent application is virtually the same as the Fuel Pump Defect at the heart of this case.

215. Subaru has admitted knowing about the Fuel Pump Defect as early as July 2019, when it claimed that it first began receiving field reports of the defective pump, including the vehicles’ no-start condition and sudden stalls while driving.³⁴ Subaru also admitted that, in January 2020, sudden shutdown also occurred at highway speeds. Based on its investigation, “Subaru found that the impeller was deformed and was likely the cause of the loss of power.”³⁵

216. Even the vehicles subjected to Subaru’s 2020 recall do not capture all of the Affected Vehicles. It does not include all of the Subaru vehicles that were equipped with Denso low-pressure fuel pumps and fuel pump assemblies, including parts that begin with part number prefix 42022-, the single common part in every model that Subaru has recalled for the admitted fuel delivery system defect.

³³ U.S. Patent Application No. 15767375, *Impeller for Fuel Pump* (Oct. 26, 2016) (applicants Denso Corporation, et al.), available at <https://patentscope.wipo.int/search/en/detail.jsf?docId=US231859533> (last visited July 7, 2020).

³⁴ Exhibit A at 7.

³⁵ *Id.* at 7.

217. Indeed, in November 2020, seven months after Subaru's initiated the 2020 recall, Denso nearly doubled the months of production and, with that, the number of admittedly defective low-pressure fuel pumps, adding over 1.5 million more low-pressure fuel pumps to the already 2 million defective low-pressure fuel pumps already known to have been used by Subaru (among other manufacturers) in their vehicles.

C. Defendants Have Not Remedied the Fuel Pump Defect in Affected Vehicles

218. The Fuel Pump Defect in the Affected Vehicles is dangerous to drivers, vehicle occupants, and innocent bystanders. A vehicle that fails to accelerate when demanded, or stalls while in motion, is simply unsafe to operate.

219. Defendants have not fixed the Recalled Vehicles, or any other Affected Vehicles, despite their admissions of the existing safety defect relating to the low-pressure fuel pump.

220. Upon information and belief, and based on Subaru's website dedicated to recalls and its more recent report to NHTSA regarding the progress of its recall,³⁶ a substantial number of the Recalled Vehicles—across all four of the Affected Vehicles—have not even been recalled yet, leaving vehicle owners without the means to repair the pump or even the knowledge that this dangerous defect exists.

221. Subaru has not included all of the Affected Vehicles in its recall. Subaru has only recalled those vehicles with fuel pumps known to have been exposed to solvent for an excessive period of time. As part of its initial recall, it did not recall all of the known, defective fuel pumps which use inadequate material for the impeller, which Denso identifies as a separate basis for its recall, and an aspect of the Fuel Pump Defect independent of any consideration of exposure to solvent. Later, after Plaintiffs brought suit, and only for those vehicles covered by its 2021 recall,

³⁶ Recall Report for the Fourth Quarter of 2020 (updated January 21, 2021).

Subaru considered the inadequate material in the fuel pumps as part of its recall, but continued to limit the recall only to those fuel pumps known to have been exposed to solvent for an excessive period of time.

222. Indeed, the part that is listed by part number in Subaru's recall is a part number that is used in far more vehicles than those subject to the Subaru's recall. For example, the "Genuine Subaru Parts" 42021AL02C and 42021AL03C are used in Subaru Outback and Legacy vehicles for model years 2015-2019.

223. Given the substantial increase of the fuel-pumps Denso has admitted are defective with its expanded recall, Subaru's already insufficient efforts to remediate the defect are likely to be further dwarfed by the true scope of the problem it has left its consumers. As of the filing of this Amended Complaint, Subaru has not taken any affirmative action to expand its recall to address the admitted scope of the problem. As for Denso, after years of concealing its knowledge of the defect, it has taken no action to redress the Fuel Pump Defect.

224. Defendants' supposed "remedy" for the 2020 Recall fails to adequately remedy the Fuel Pump Defect in those vehicles Subaru has acknowledged contain the Fuel Pump Defect. The proposed "fix" merely provides a bare-bones instruction to Subaru dealers' auto repair technicians to remove the existing fuel pump module in the vehicle and to replace *only* the fuel pump *motor* in the module (the "Recall Repair"). Because of the risk of damage to the entire fuel pump module if only the fuel pump motor is removed and replaced, it is industry standard to replace the *entire* fuel pump module in the event the fuel pump motor is defective (such as here). However, contrary to industry practice, the Recall Repair replaces only the *motor*, placing Plaintiffs and the Class at an increased risk of experiencing additional hazardous conditions as a result of technician error or due to degradation of other components of the fuel pump module.

225. Upon information and belief, the Recall Repair originated from Denso, the manufacturer of the defective fuel pumps that gave rise to Subaru's 2020 Recall. Denso sells its fuel pumps to automobile manufacturers as part of a fuel pump module. In a cost-savings effort, Denso provided only the defective fuel pump *motor*, and not the entire fuel pump *module*, for Subaru's Recall Repair, despite knowing that industry norms would require the replacement of the entire fuel pump module to adequately remedy the Fuel Pump Defect (assuming, of course, that the new fuel pump assembly functioned properly). Subaru, fully aware that this Recall Repair would be entirely inadequate, and indeed would risk causing further damage to the fuel pump module and other component parts, decided to implement this insufficient remedy anyway. That is because it, like Denso, did not want to incur the costs of providing entire fuel pump modules, which would be more expensive than swapping out the fuel pump motors in the fuel pump modules in the Recalled Vehicles. Indeed, despite the moderately increased labor time, the Recall Repair is \$300 to \$400 cheaper for each Recalled Vehicle for Subaru to implement than the industry-standard replacement of the entire fuel pump module. The cost to Plaintiffs and Class members to replace the fuel pump module in the Affected Vehicles, which is the only complete and adequate repair of the defective fuel pump, is approximately \$500 to \$800. Thus, Denso and Subaru are equally responsible for the inadequate Recall Repair and share equal blame for the potential hazards it presents.

226. The Recall Repair involves both the fuel pump and the fuel pump module, which houses the fuel pump. The Fuel Pump (i.e., the electric motor and impeller) is an internal component of the fuel pump module. The fuel pump module is a complete package, hosting the pump, associated plumbing and the fuel gauge sending unit. Figure 6 below is a photograph of the Denso fuel pump module used in Class Vehicles.

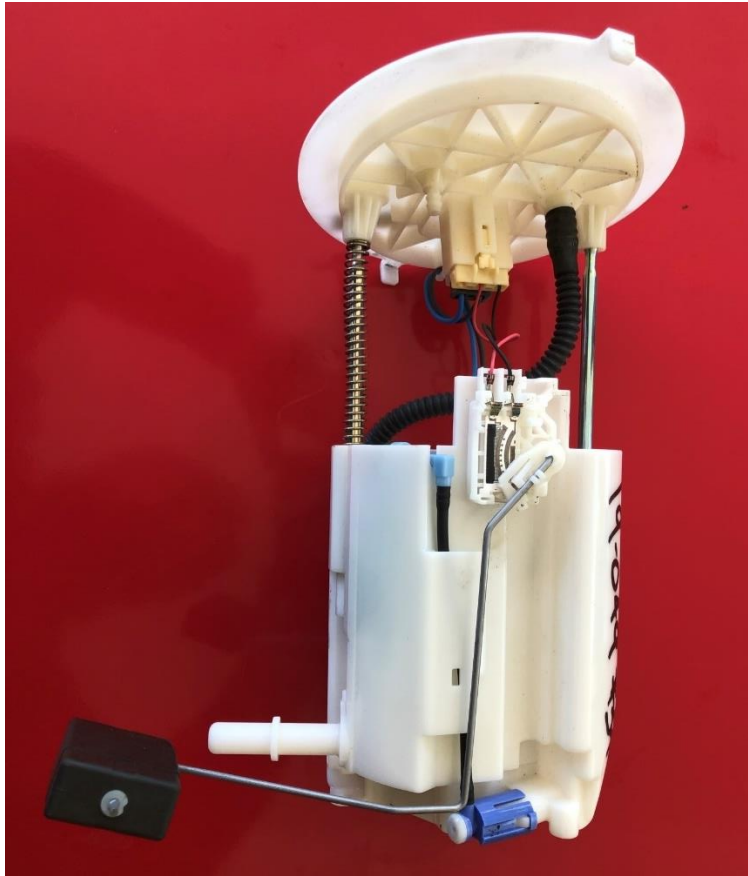

Figure 6

227. As Figure 7 below demonstrates, the fuel pump module drops into the fuel tank through an access hole on the topside of the tank. A retainer ring ensures that the flange and O-ring create a tight seal against the tank surface, preventing fuel escape.

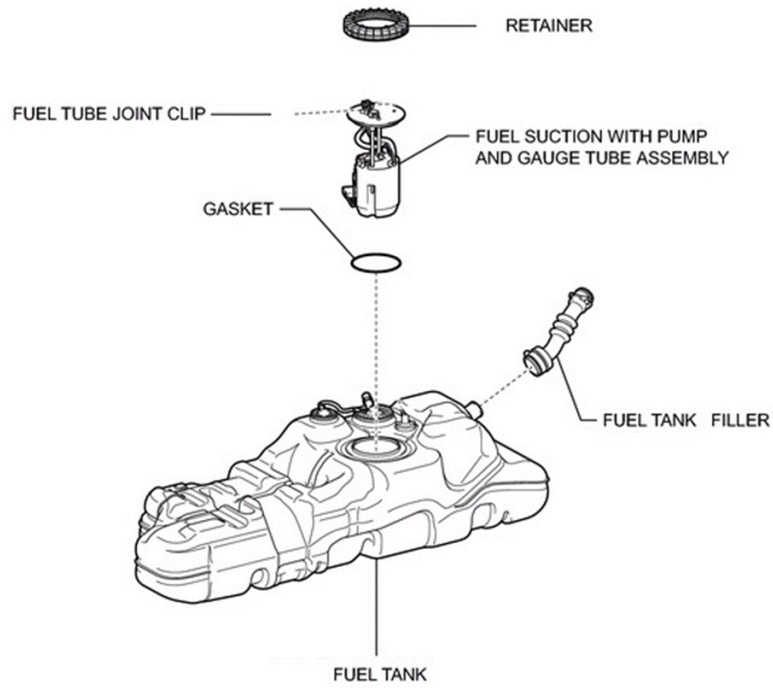

Figure 7

228. Figure 8 below depicts the component parts of a Denso fuel pump module.



229. The fuel pump module's housing protects the fragile internal components that fit together like puzzle pieces within the module.

230. As Figures 9 and 10 below demonstrate, the Denso fuel pump module is held together with plastic tabs and clips.



Figure 9

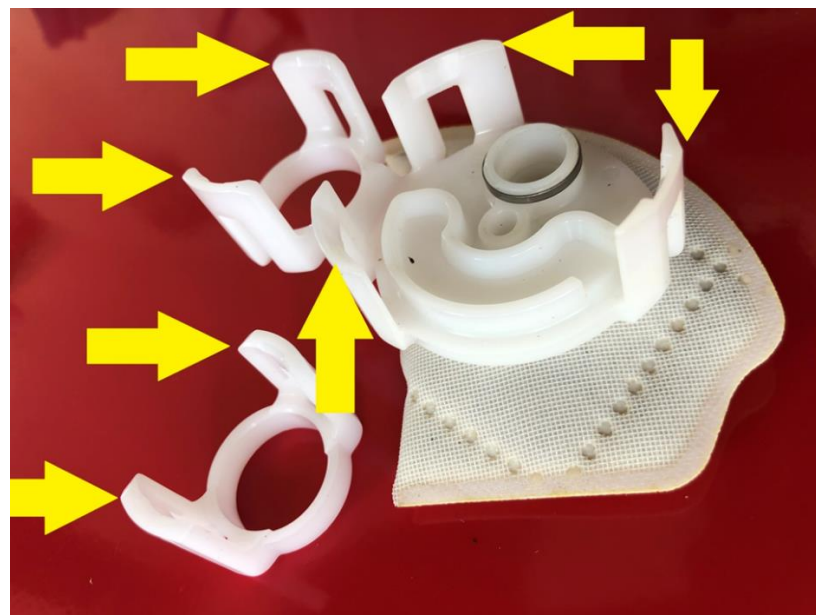

Figure 10

231. Fuel exposure weakens these plastic tabs and clips depleting durability and elasticity.

232. As Figure 11 below demonstrates, the fuel pump modules contain numerous small and fragile parts, such as O-rings, that require precise installation. Disassembling the fuel pump module exposes these critical components to contamination, dislocation and breakage, thereby affecting vehicle performance in the near term, and generally strains and weakens the components and connectors, substantially shortening the life and reliability of the fuel pump assembly.



Figure 11

233. Because of these concerns (and others), it is industry standard to replace the fuel pump module as a complete unit rather than remove and replace discrete failed internal components. Replacing the fuel pump module as a complete unit greatly reduces technician error frequency.

234. However, as Subaru's July 16, 2020, Service Bulletin³⁷ demonstrates, Subaru ignored industry norms and instructed technicians to disassemble the fuel pump module to replace

³⁷ Subaru's July 16, 2020 Service Bulletin WRD-20R, instructing technicians as to how to perform the Recall Repair, is attached as Exhibit H. Service Bulletin WRG-21 issued as part of its expanded 2021 recall provides the same instructions, and is attached as Exhibit I.

the fuel pump (i.e., the electric motor and impeller) when performing the “remedy” under the Recall. Rather than replace the entire fuel pump module, Subaru’s Recall directs technicians to replace only the fuel pump motor, an extremely delicate process requiring the technician to disassemble the fuel pump module, remove the motor, replace the old motor with a new one, and then reassemble the fuel pump module. This process involves bending tabs and clips, which in turn invite hairline cracks, breakage and incomplete catching of the tabs and clips that hold the fuel pump module together. These common and likely labor errors create seal failure and resultant fuel leaks and/or fuel pressure loss due to cavitation³⁸ or recycling of fuel.

235. First, Subaru’s Recall Repair instructs technicians to remove the fuel pump module from the fuel tank and disassemble it to extract the fuel pump motor.

³⁸ Cavitation is a phenomenon in which rapid changes of pressure in a liquid lead to the formation of small vapor-filled cavities in places where the pressure is relatively low. When subjected to higher pressure, these cavities, called “bubbles” or “voids,” collapse and can generate a shock wave that strong enough to damage component parts.

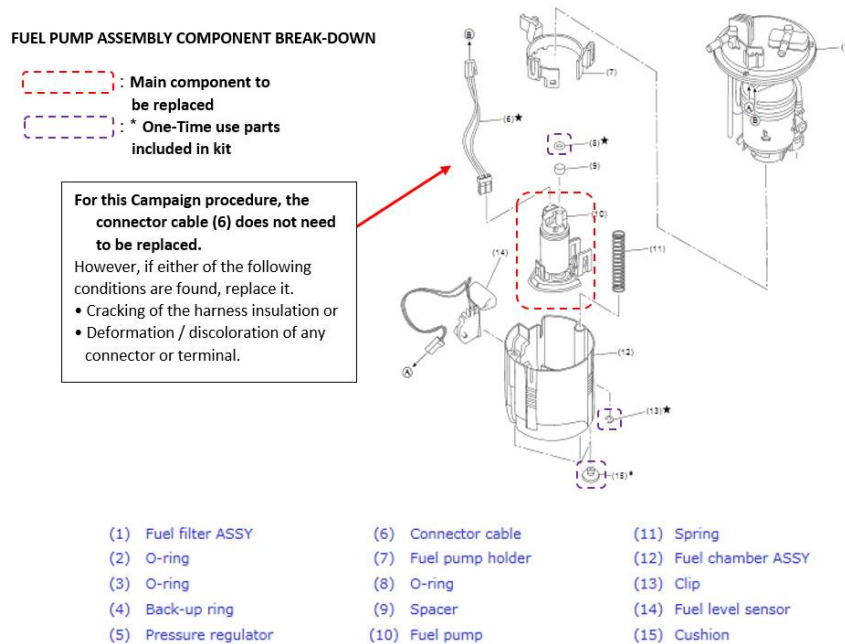

*The 3 rubber cushions (15) on the bottom of the fuel chamber and included in the kit must be replaced as they are 1-time use.

236. Following removal of the recalled fuel pump, Subaru instructs technicians to install a new one. Once the new fuel pump is installed inside of the original fuel pump module, Subaru instructs technicians to reassemble the fuel pump module and insert in the fuel tank.

237. Subaru acknowledged the potential for the technician error component damage. For example, Subaru warned that nuts and studs “may be damaged” if not handled properly, that the filter assembly bore may be scratched by removing the O-ring, and that various components, from O-rings and gaskets to fuel routing lines, may easily become pinched.

238. Even if the technician manages to complete the Recall Repair without causing immediate damage to and/or failure of the fuel pump module, such as immediate and substantial fuel leaks, the process still damages and/or weakens each of the components that are touched, impacted or otherwise involved in the process. The fuel pump module is not to be tampered with and is not designed or manufactured to be disassembled for repairs or replacement of internal components. Each of the plastic tabs and clips, rings, wires, fuel connectors, electric connections

and other parts and components in the fuel pump module are supposed to left in place, not clicked and unclicked, bent and twisted, disconnected and reconnected, or otherwise removed and put back into place. The Subaru mandated process set forth for the Recall Repair exposes these connectors, junctions, parts and components to stresses and forces that substantially weakens and compromises the integrity and durability of these components. These plastic tabs, wire clips, rings, wires, fuel connectors and electrical connections in the fuel pump module are more prone to failure and will fail sooner than such components that were not interfered with once the Recall Repair is completed. Such damage will lead to the premature failure of the fuel pump module, causing the same risks, problems and conditions as those associated with the Fuel Pump Defect - starting with impeded engine performance and ultimately leading to stalling - but will more likely manifest after any relevant warranty coverage has passed.

239. Despite acknowledging risk of component damage when performing the Recall Repair, Subaru failed to adequately train technicians on methods to prevent such damage. For example, Subaru failed to train technicians on the complicated procedures required to adequately preserve tabs, clips, and other fragile components of the fuel pump module. Instead, Subaru expected technicians to develop their repair skills in the field, using Class Vehicles.

240. In another example of the inadequacy of the Recall Repair, Subaru instructed technicians to reuse fuel filters, ignoring a logical opportunity to replace worn, used fuel filters with new ones. This obvious cost-saving decision can lead to fuel filter contamination (especially in a shop environment), which in turn increases the risk of the fuel pump module clogging and the fuel not reaching the engine, potentially resulting in the dangerous stalling events associated with the Fuel Pump Defect.

241. Subaru's Recall Repair is consistent for substantially all Recalled Vehicles.

242. Subaru's Recall Repair not only deviates from industry norms, but it also departs from Subaru's typical practice. For example, outside of this Recall, customers who bring their vehicles to a technician for fuel pump repair typically receive a new fuel pump module. In fact, recycling of original fuel pump module parts does not occur outside of this Recall.

243. The cost to owners of Affected Vehicles to complete a full and complete replacement of the fuel pump assembly is estimated to require over an hour of labor (approximately \$150) and up to \$575 in parts. Without making such an investment, an owner or lessee of an Affected Vehicle will not be put in the place they should have been as purchasers or lessees but for the Fuel Pump Defect.

244. Confirming the risks posed by the recall repair, many owners have filed incident reports with NHTSA, noting the overwhelming smell of gasoline in their vehicles, fuel leakage from the fuel pump, and other dangerous conditions, including failure to start and stalling.³⁹

245. Rather than spend the money necessary to address the defect, or at least warn its customers that they have cars equipped with faulty fuel pumps, Defendants have shifted the significant and serious risk of inoperable vehicles, accidents, injury, and even death onto its customers.

246. Defendants have not recommended or advised that consumers stop driving Affected Vehicles pending repair or replacement of the Fuel Pump Defect. Even though they know and admit that the Fuel Pump Defect could cause high-speed stalls and other dangerous conditions, Defendants are unwilling to spend the money necessary to provide alternative transportation to its

³⁹ See e.g. NHTSA Complaints 11338379 (no start, smell of gasoline), 11338331 (stall on highway), 11350937 (corrosion of wiring from fuel leak), 11363767 (running rough), 11325641 (engine dies), 11324815 (erratic acceleration entering highway), and 11340309 (stall on highway).

customers. Instead, Defendants make them choose between driving a car with a known dangerous defect or driving nothing at all. On information and belief, most owners of Affected Vehicles have no idea that the low-pressure fuel pumps in their supposedly safe and reliable Subaru vehicles have a known safety defect and have been the subject of a massive recall. To this day, Subaru has not notified a substantial number of them of the 2020 safety recall.

D. NHTSA Complaints Reveal That the Fuel Pump Defect Poses Serious Safety Risks

247. Affected Vehicle owner complaints to NHTSA describe harrowing traffic events and near misses, making perfectly clear that this is not a defect that Subaru can continue to ignore.

248. Indeed, despite knowledge of the defective fuel pumps for years, Defendants failed to disclose and delayed disclosure to the NHTSA in response to substantial complaints by owners and lessees.

1. Pre-2019 Vehicles with the Defective Pump

249. These complaints go back several years, further demonstrating both Subaru's knowledge of the defect and that the defect affects more vehicles than those recalled by Subaru.

For example, on January 17, 2017, a 2013 Subaru Outback owner reported to NHTSA as follows:⁴⁰

ON MULTIPLE OCCASIONS, THE VEHICLE STALLED, AS IN THE ENGINE DIED. THIS IS AN INTERMITTENT PROBLEM. USUALLY IT HAPPENS WHEN THE VEHICLE IS STARTED, THE ENGINE WILL DIE, THIS WILL HAPPEN 2-3 TIMES ON EACH OCCURRENCE. IT DOES EVENTUALLY START AND RUN CORRECTLY. A SIMILAR ISSUE OCCURS WHEN COMING TO A STOP. THE ENGINE WILL "FLUTTER" ALMOST DIE AND THEN RESUME NORMAL OPERATION. SO FAR IT HAS NOT LEFT US STRANDED, HOWEVER, I AM CONCERNED AS TO WHAT THE PROBLEM MIGHT BE AND AT WHAT POINT WILL IT STALL AND NOT START AGAIN. I PLAN ON TAKING IT TO MY DEALERSHIP AND HAVE THEM LOOK AT IT, HOWEVER, THE ENGINE LIGHT HAS

⁴⁰ NHTSA Complaint 10945876. All NHTSA complaints and reports are copied and pasted as-is; all emphases added.

NOT COME ON SO I DON'T EXPECT THE COMPUTER HAS STORED ANY CODES FOR THE MECHANIC TO BE ABLE TO TROUBLESHOOT.

250. On April 17, 2017, a 2013 Subaru Outback owner reported to NHTSA as follows:⁴¹

ISSUE: OCCASIONAL NON-RESPONSE WHEN DEPRESSING THE ACCELERATOR.

1ST OCCURRENCE ABOUT THREE WEEKS AGO HAPPEN WHEN I STOPPED FOR A LIGHT AND THEN ATTEMPTED TO ACCELERATE. DEPRESSING THE PEDAL HAS NO RESPONSE, ATTEMPTED THIS THREE TIMES. THE RPM GAUGE REFLECTED IT WAS RUNNING. I TURNED ON THE CAR AND STARTED IT AGAIN AND IT WORKED.

2ND OCCURRENCE HAPPENED AGAIN AFTER A STOP. SAME AS ABOVE.

3RD OCCURRENCE MAY 6 2017 RETURNING FROM BWI IN BALTIMORE ON THE INTERSTATE, I WAS IN HEAVY TRAFFIC. I HAD TO SLOW QUICKLY FOR A TRUCK AND THEN SAW AN OPENING IN THE LEFT LANE AND PULLED OUT INTO THE LEFT LANE AND ATTEMPTED TO ACCELERATE WITH NO RESPONSE. ***A CAR MOVING FAST IN THE LEFT LANE ALMOST HIT ME SINCE I COULD NOT ACCELERATE.*** I PUMPED THE ACCELERATOR TWICE AND IT THEN ACCELERATED.

4TH OCCURRENCE MAY 6TH 2017 DEPARTING A PARKING LOT I WAS MOVING SLOWLY THEN ATTEMPTED TO ACCELERATE AND EXPERIENCED A DELAYED RESPONSE. PUMPED THE PEDAL TWICE TO GET THE RESPONSE.

WENT TO A SUBARU DEALER AFTER THE FIRST TWO OCCURRENCES AND THEY SAID THEY COULD NOT IDENTIFY THE PROBLEM. THE DEALER CALLED AGAIN AND REQUESTED WE BRING THE CAR IN AGAIN APRIL 11TH.

A WEB SEARCH REVEALED ABOUT 24 OTHIS LIKE OCCURRENCES WITH OUTBACK ABOUT THE SAME YEAR AND MAKE.

⁴¹ NHTSA Complaint 10971205.

251. On March 8, 2013, a 2013 Subaru Impreza owner reported to NHTSA as follows:⁴²

VEHICLE WILL NOT START AFTER AN EXTENDED PERIOD OF ATTEMPTS. APPEARS TO HAPPEN MOST OFTEN WHEN VEHICLE IS PARKED (EITHERS INDOORS OR OUTSIDE) FOR MORE THAN SEVERAL HOURS. CAR WILL CRANK OVER FOR 10+ SECONDS AND WILL NOT START. AFTER MULTIPLE ATTEMPTS, CAR HAS STARTED EVENTUALLY.

HAVE COMMUNICATED WITH DEALER AND SIA OFFICES THAT I HAVE NOTICED THE CAR WILL MAKE WHIRRING NOISES THAT COME FROM THE BACK RH SIDE OF VEHICLE - AND ALSO A CLICKING NOISE NEAR CENTER OF DASH WHEN TURNED OFF AND SITTING. THIS WILL GO ON FOR OVER 5 MINUTES AT A TIME, WHICH MUST DRAIN BATTERY SINCE CAR IS NOT TURNED ON OR ENGINE RUNNING. WAS TOLD BY DEALER THAT THIS IS THE EMISSION SYSTEM "PURGING" ITSELF - AND IS CONSIDERED NORMAL FOR THIS VEHICLE. SIA OFFICES CONFIRMED THIS AND ALSO STATED THAT NOTHING IS NOTED IN THE CURRENT OWNERS MANUAL WHICH EXPLAINS THIS FEATURE.

MY CONCERN IS THAT THE CAR IS UNABLE TO START WHEN REQUIRED TO - AND AM GUESSING THAT IT MIGHT BE RELATED TO THIS UNUSUAL FEATURE... . REGARDLESS OF ORIGIN, SAFETY ISSUE WITH CAR NOT STARTING AND BEING READY TO OPERATE WHEN NORMAL STARTING PROCEDURES ARE FOLLOWED.

252. On January 25, 2017, a 2013 Subaru Legacy owner reported to NHTSA as follows:⁴³

THE CAR INTERMITTENTLY LOSES POWER WHEN ACCELERATING FROM A STOPPED POSITION. MOST OFTEN HAPPENS WHEN I AM TURNING LEFT. SUBARU SAYS THESE ARE NO COMPUTER CODES IN THE CHECK ENGINE HISTORY. CAUSE UNKNOWN BUT SPECULATION ADVANCED ABOUT NEURAL NETWORK LEARNING OF THE COMPUTER (SEEMS WORST AFTER RECENT ENGINE REBUILD UNTIL CAR WAS DRIVEN FOR A COUPLE OF DAYS WHISE FREQUENCY OF POWER LOSS DIMINISHED

⁴² NHTSA Complaint 10502043.

⁴³ NHTSA Complaint 10947694.

BUT NOT GO AWAY). . . . FULL GAS TANK VS 1/2 OR LESS , FUEL STARVATION CAUSES POWER DROP (NOTE: ENGINE DOESN'T FULLY DIE & CAN BE COAXED BACK TO LIFE BY PUMPING THE ACCELERATOR), ELECTRONIC IGNITION SYSTEM PERHAPS THE CULPRIT. ***THIS PROBLEM IS DANGEROUS BECAUSE OF THE RANDOM & SUDDEN (WITHOUT WARNING) LOSS OF POWER WHICH ANY DRIVER IMMEDIATELY BEHIND MY CAR WOULD NOT BE EXPECTING & THISEBY CAUSE A REAR-END COLLISION. ALSO, DANGEROUS WHEN ENTERING A LANE OF TRAFFIC & SUDDENLY THE POWER IS GONE JUST WHEN YOU NEED ACCELERATION IN ORDER TO MERGE AT TRAFFIC SPEED INTO YOUR LANE.*** SOMETIMES PROBLEM OCCURS WHEN GOING UP A LOW ANGLE INCLINE (EST. 10-15 DEGREES?) BUT NOT NECESSARILY. WHEN LEAVING A STOPPED POSITION, IF LEFT FOOT IS ON THE BRAKE & RIGHT IS SLIGHTLY ACCELERATING IN ORDER TO PULL AWAY MORE RAPIDLY FROM STOPPED POSITION, THE CONTROLLING COMPUTER WILL SOMETIMES PROVIDE ZERO POWER TO THE ACCELERATOR BUT THIS HAPPENS ONLY OCCASIONALLY & OFTEN WILL WORK JUST FINE TO GIVE THE EXTRA ACCELERATION NEEDED. SUBARU SAYS THIS CONFUSES THEIR COMPUTER & IT WILL SHUT DOWN BUT I HAVE FOUND THAT THIS HAPPENS ABOUT 1/3 OF THE TIME, IN MY EXPERIENCE. DANGER COMES FROM LOSING POWER DURING THE TIME YOU NEED IT THE MOST ESP. LEFT TURNS WHICH CROSS TRAFFIC LANES BEFORE YOU CAN MERGE AND DRIVING COMPLETELY NORMALLY.

253. On March 15, 2020, a 2014 Subaru Outback owner reported to NHTSA as follows:⁴⁴

DELAYED GAS PEDAL RESPONSE=HESITATION TO ACCELERATE WHEN GAS PEDAL ENGAGED FROM A STATIONARY STOP. I HAVE EXPERIENCED THIS FAILURE TO ACCELERATE THE VEHICLE FROM A STOPPED POSITION IN EXCESS OF 25 TIMES OVER A MORE THAN 5 YEAR PERIOD.

⁴⁴ NHTSA Complaint 11318118.

THE SUBARU IS NOT MINE BUT A RELATIVES CAR. IN EARLY FEBRUARY 2019, I WAS STOPPED AT A LIGHT ATTEMPTING TO MAKE A LEFT HAND TURN.

TRAFFIC COMING AT ME WAS UP A HILL WITH A GRADE OF 6% OR MORE WHICH LIMITED THE LINE OF SIGHT FOR SOMEONE WANTING TO MAKE A LEFT HAND TURN AT THAT INTERSECTION. AS I STEPPED ON THE GAS TO MAKE THE TURN THISE WAS NO RESPONSE FROM THE CAR. THE CAR COMING UP THE HILL WAS UPON ME. I PUMPED THE GAS SEVERAL TIMES AND LUCKILY WAS ABLE TO MAKE IT THROUGH THE *INTERSECTION. MY WIFE AND I WERE INCHES AWAY FROM BEING WACKED BY THE OTHIS CAR.* THE CAR APPROACHING HAS A SPEED LIMIT OF 45 MPH BUT WAS MOST LIKELY TRAVELING IN EXCESS OF 45 MPH. ONCE THROUGH THE INTERSECTION, WE PULLED TO THE CURB TO GATHIS OURSELVES.

THAT'S WHEN I SAID ENOUGH IS ENOUGH AND SENT TWO LETTERS TO TOM DOLL OF SUBARU. ONE IN FEBRUARY & APRIL 2019. HE OF COURSE PASS IT ON TO CSERVICE. THE INDIVIDUAL WROTE BACK SAYING NOTHING IS WRONG.

I AM A PROFESSIONAL ENGINEER AND HAVE BEEN FOR MANY YEARS. I POINTED OUT ALL ENGINEERS INCLUDING AUTOMOTIVE ENGINEERS MUST ADHISE TO A CODE OF ETHICS & ADHISE TO THE "HIGHEST STANDARDS OF HONESTY AND INTEGRITY, AND MUST BE DEDICATED TO THE PROTECTION OF THE PUBLIC HEALTH, SAFETY AND WELFARE AND MUST ADHISE TO THE HIGHEST

PRINCIPLES OF ETHICAL CONDUCT." THAT MEANT NOTHING TO SUBARU.

CLEARLY FROM MY EXPERIENCE THISE IS A PROBLEM WITH THE 2014 SUBARU OUTBACK AND IT'S RANDOM FAILURE TO ACCELERATE DUE TO A DELAYED GAS PEDAL RESPONSE.

254. On February 3, 2019, a 2014 Subaru Outback owner reported to NHTSA as follows:⁴⁵

3 TO 15 SECOND HESITATION IN THROTTLE RESPONSE. ***LAST INCIDENT NEARLY RESULTED IN A COLLISION. I STOPPED WAITING FOR TRAFFIC TO CLEAR BEFORE MAKING AN LEFT TURN.*** MADE THE LEFT TURN, GENTLY APPLIED THE THROTTLE PEDAL, NO RESPONSE, PUSHED IT TO MAXIMUM TRAVEL, STILL NO RESPONSE, CAR COMING TOWARD ME IN ONCOMING LANE, THEN MY CAR SUDDENLY ACCELERATED SO THAT A COLLISION WAS AVOIDED. CITY 2 LANE STREET, TURNING LEFT.

255. On August 17, 2017, a 2014 Subaru Outback owner reported to NHTSA as follows:⁴⁶

ACCELERATION FROM A STOP OR SLOW SPEED TAKES 5-6 SECONDS FOR A PROPER RESPONSE. ***TURNING LEFT IS A VERY REAL PROBLEM OR PULLING INTO ON COMING TRAFFIC. I HAVE YET TO HAVE AN ACCIDENT BECAUSE I AM EXTREMELY CAREFUL, BUT HAVE COME FRIGHTINGLY CLOSE A FEW TIMES.*** CAN THIS PROBLEM BEFIXED?

THIS HAPPENS WHEN THE VEHICLE IS STATIONARY, TURNING,BRAKING (SLOWING DOWN AND THEN TRYING TO GO BACK TO NORMAL SPEED. THIS HAPPENS ON INTERSTATES, AROUND TOWN, ETC

256. On April 24, 2017, a 2015 Subaru Outback owner reported to NHTSA as follows:⁴⁷

AT TIMES WHEN YOU PRESS THE ACCELERATOR FROM A STOP IT TAKES 5 OR 6 SECONDS TO RESPOND.I WAS PULLING ON TO THE HIGHWAY TURNING LEFT.***THIS COULD BE A VERY DANGEROUS OR EVEN FATAL INCIDENT IF THESE WAS ONCOMING TRAFFIC.READING FROM THE INTRNET I SEE THAT THIS HAS BEEN A PROBLEM AS FAR BACK AS 2013.SOMEONE NEEDS TO FIX THIS PROBLEM BEFORE SOMEONE DIES.***

⁴⁵ NHTSA Complaint 11318118.

⁴⁶ NHTSA Complaint 11015970.

⁴⁷ NHTSA Complaint 10980329.

257. On May 20, 2015, the owner of a 2014 Subaru Outback filed the following complaint with NHTSA:⁴⁸

VEHICLE HESITATES OCCASIONALLY ON
ACCELERATION COMING OFF A STOP.

258. On October 24, 2014, the owner of both a 2014 Subaru Legacy and a 2013 Subaru Impreza reported to NHTSA as follows:⁴⁹

VEHICLE HAD A 2-5 SECONDS ACCELERATION HESITATION. TAKING OFF FROM A YIELD SIGN AND GOING ACROSS A HWY, THE CAR HAD ENOUGH POWER TO ROLL FORWARD. TRIED FLOORING THE ACCELERATOR, BUT ALSO DID NOT RESPOND TO FULL THROTTLE UNTIL AFTER A FEW SECONDS THE CAR STARTED TO SLOWLY MOVE. THE ENGINE IS ON LOW RPMS AND DOES NOT LAUNCH FORWARD AS TO INDICATE A TRANSMISSION ISSUE IT LOOKS MORE LIKE A FUEL DELIVERY OR THROTTLE SENSOR ISSUE.

I ALSO HAD THIS SAME ISSUE WITH A 2013 SUBARU IMPREZA (TRADED IN THE IMPREZA THINKING IT WAS A QUIRK WITH THE CAR). SUBARU DEALER WAS NOT BEEN ABLE TO REPRODUCE THE ISSUE ON THE IMPREZA OR THE ON THE LEGACY. NO ERROR CODES PRESENT.

I CONTACTED SUBARU OF AMERICA, I WAS INSTRUCTED TO TAKE THE CAR (LEGACY) TO THE DEALER. THE TECHNICIAN WAS NOT ASKED TO ATTACH ANY KIND OF DIAGNOSTIC EQUIPMENT TO POSSIBLY CAPTURE VALUABLE DATA IN THE EVENT THAT THE ISSUE WAS REPRODUCED. WHEN THE PROBLEM HAS MANIFESTED, I HAVE ACCELERATED FROM A COMPLETE STOP OR FROM A SLOW ROLLING YIELD, THEN 2 - 5 SECOND DELAY IN ACCELERATION - VERY SLOW ROLL FORWARD. I SHARED THIS INFORMATION WITH THE DEALER.

MY FAMILY AND I ALMOST GOT HIT A FEW WEEKS AGO BY A CAR GOING AROUND 60 MPH AND I WAS ALMOST HIT WHEN DRIVING THE IMPREZA (LET THE CAR ROLL BACK TO AVOID BEING HIT - I WAS ON SMALL INCLINE

⁴⁸ NHTSA Complaint 10717533.

⁴⁹ NHTSA Complaint 10649644.

LEAVING MY NEIGHBORHOOD AND TRYING TO MERGE ONTO A HWY).

MANY SUBARU OWNERS ARE HAVING THE SAME ISSUE (OLD / NEW VEHICLES). ***THESE ARE SOME BLOGS WHISE CUSTOMERS MENTION HAVING BEEN IN AN ACCIDENT BECAUSE OF THIS ISSUE*** AND PLENTY OF BLOGS WHISE CUSTOMERS REPORT THE PROBLEM AND FRUSTRATION WHEN THE PROBLEM CANNOT BE REPRODUCED AND ARE SENT HOME WITHOUT A FIX.

HOW CAN SAFERCAR.GOV HELP COMMUNICATE THE IMPORTANCE OF THE ISSUE TO SUBARU BEFORE A FATALITY?

259. On November 15, 2014, a 2014 Subaru Legacy owner reported to NHTSA as follows:⁵⁰

I PURCHASED MY BRAND NEW 2014 SUBARU LEGACY ON MAY 16TH 2014. ABOUT ONE WEEK LATER I WAS DRIVING UP THE SLIGHT INCLINE OF THE DRIVEWAY OF THE APARTMENT HOUSE WHISE I LIVE. AS I REACHED THE STREET I STEPPED ON THE ACCELERATOR TO TURN OUT INTO THE TRAFFIC AND THE CAR COMPLETELY LOST POWER. ABOUT 5 SECONDS LATER THE POWER RETURNED AND THE CAR RESPONDED NORMALLY WHEN I STEPPED ON THE ACCELERATOR PEDAL AND I WAS ABLE TO DRIVE THE CAR NORMALLY. THREE OR FOUR DAYS LATER THE SAME THING HAPPENED AGAIN WHILE I WAS DRIVING IN TRAFFIC, AS I TRIED TO ACCELERATE THE CAR'S ENGINE LOST POWER WHEN I STEPPED ON THE ACCELERATOR. THIS SAME LOSS OF POWER NOW HAPPENS ABOUT TWO OR THREE TIMES EACH WEEK. I CURRENTLY HAVE ABOUT 2500 MILES ON THE CAR. I HAVE TAKEN IT TO MY LOCAL SUBARU DEALERSHIP ON THREE SEPARATE OCCASIONS FOR THIS COMPLAINT AND THEY HAVE KEPT THE CAR FOR A TOTAL OF ABOUT THIRTY DAY FOR OBSERVATION, TESTING, AND REPAIR BUT THEY HAVE BEEN UNABLE TO REPRODUCE OR SOLVE THE PROBLEM AND CAN FIND NOTHING WRONG WITH MY CAR. THEY WARNED ME ABOUT DRIVING WITH TWO FEET BECAUSE IF THE BRAKE IS APPLIED AT THE SAME TIME AS THE

⁵⁰ NHTSA Complaint 10655186.

ACCELERATOR A PROBLEM LIKE THIS COULD OCCUR BUT I DO NOT DRIVE USING BOTH FEET AND HAVE ALWAYS DRIVEN USING ONLY ONE FOOT.

260. On August 12, 2017, a 2015 Subaru Outback owner reported to NHTSA as follows:⁵¹

GAS PEDAL SENSOR DOSE NOT RESPOND ON TAKE OFF FROM STOPPED VEHICLE. **HAVE ALMOST BEEN T-BONE 5-6 TIMES**. ALSO FROM A COST TO PUTTING PRESSURE ON PEDAL IT FAILS TO RESPOND. ON LEFT TURNS YOU ARE A SITTING DUCK NOT KNOWING IF PEDAL WILL RESPOND OR YOU ARE SITTING OUT IN FRONT OF SOME CLOSING IN ON YOU AT HIGH RATE SPEED THIS HAS HAPPENED 10 -12 TIMES ON HIGHWAYS AN CITY STREETS

261. On April 6, 2020, a 2015 Subaru Outback owner reported to NHTSA as follows:⁵²

TL* THE CONTACT OWNS A 2015 SUBARU OUTBACK . THE CONTACT STATED THAT THE VEHICLE FAILED TO START. THESE WERE NO WARNING LIGHTS ILLUMINATED. THE LOCAL DEALER WAS NOT CONTACTED. THE MANUFACTURER WAS CONTACTED BUT NO FURTHIS ASSISTANCE WAS PROVIDED. THE FAILURE MILEAGE WAS 69,000.

262. On February 12, 2019, a 2015 Subaru Outback owner reported to NHTSA as follows:⁵³

THE CAR WOULD STALL WHEN COASTING TO A STOP LIGHT OR STOP SIGN A FEW TIMES AND HAVE BEEN BACK TO THE DEALER AND CAN'T REPLICATED THE PROBLEM. **THIS IS A DANGEROUS SITUATION AND CAN CAUSE AN UNSAFE AND HUGE ACCIDENT WITH MY FAMILY. THE CAR WOULD DIE WHILE IN DRIVE AND SOMETIMES CAN'T BE RESTARTED**. IT'S HAPPENING AGAIN AND AFRAID TO DRIVE THE CAR SINCE THE DEALER WILL SAY NOTHING IS WRONG WITH THE CAR. IT LOOKS LIKE IT'S RELATED TO IDLE BEING LOW OR THE CVT ACTING UP WHEN TAKING THE FOOT OFF THE

⁵¹ NHTSA Complaint 11014803.

⁵² NHTSA Complaint 11320331.

⁵³ NHTSA Complaint 11176539.

GAS PEDAL AND TRY TO ACCELERATE FROM A DEAD STOP OR COASTING TO A STOP. THIS HAPPENED A FEW TIMES DURING FACTORY WARRANTY WINDOW.

263. On May 27, 2016, a 2015 Subaru Impreza owner reported to NHTSA as follows:⁵⁴

CAR WILL HAVE A SLOW OR NON RESPONSIVE START FROM A STOP.. THISE WILL BE A COUPLE SECOND LAG FROM THE TIME I PRESS ON THE ACCELERATOR.

264. On January 2, 2019, the owner of a 2016 Subaru Outback filed the following complaint with NHTSA:⁵⁵

ON TWO OCCASIONS WHILE DRIVING ON THE INTERSTATE AT 65-75 MPH WITH NO WARNING THE GAS PEDAL STOPPED RESPONDING TO INPUTS. WHILE MANEUVERING THE VEHICLE TO THE SHOULDER OF THE ROAD THROUGH TRAFFIC THE ENGINE SHUTOFF. ON ONE OCCASION I WAS ABLE TO RESTART THE VEHICLE AND ON THE SECOND OCCASION IT WOULD NOT RESTART. AFTER TOWING THE VEHICLE TO A REPAIR SHOP THE VEHICLE STARTED UP AND RAN WITH NO ISSUES. NO CHECK ENGINE LIGHTS WERE EVER DISPLAYED. THE BATTERY WAS WORKING FINE AND FULLY CHARGED. THE CAR IS IN PERFECT MECHANICAL SHAPE WITH ALL REGULAR SERVICE PERFORMED. THE GAS REMAINING AT TIME OF INCIDENT WAS APPROXIMATELY 1/4 TANK FULL. THE CAUSE IS UNKNOWN TO ME.

265. On July 13, 2018, a 2016 Subaru Outback owner reported to NHTSA as follows:⁵⁶

AFTER STOPPING AT A STOP SIGN ON A CITY STREET, I TRIED TO ACCELERATE BUT THISE WAS A LONG HESITATION FOLLOWED BY A SURGE OF POWER. THIS HAPPENED ON 2 OCCASIONS. I HAD THE SALES MAN DRIVE THE VEHICLE AND ALSO THE SERVICE MANAGER DROVE IT FOR 1 WEEK - NEITHIS TIMES DID THIS ISSUE REPEAT ITSELF. THE DEALERSHIP DID NOT HAVE ANY KNOWLEDGE OF THIS TYPE OF PROBLEM. I REFUSED TO

⁵⁴ NHTSA Complaint 10871184.

⁵⁵ NHTSA Complaint 11164684.

⁵⁶ NHTSA Complaint 11111266.

DRIVE THIS VEHICLE AND RETURNED IT TO THE SUBARU DEALER IN BERLIN, CT.

266. On January 29, 2020, a 2017 Subaru Outback owner reported to NHTSA as follows:⁵⁷

CAR LOST POWER AND ENGINE SHUT DOWN WHILE AT FREEWAY SPEED WITH 1/8 TANK APPARENT REMAINING ON THE GAS GAUGE AND 60 MILES REMAINING ON THE MILES TO GO INDICATOR. ADDED 1 GALLON AT ROADSIDE AND CAR STARTED IMMEDIATELY. ADDED AN ADDITIONAL 15.5 GALLONS AT A STATION 12 MILES FROM POINT THE ENGINE SHUT DOWN. THIS LEAVES BETWEEN 2 AND 2.5 GALLONS OF UNUSED FUEL IN THE TANK AT THE POINT THE CAR SHUT DOWN FROM FUEL STARVATION.

267. On October 30, 2019, a 2017 Subaru Outback owner reported to NHTSA as follows:⁵⁸

TL* THE CONTACT OWNS A 2017 SUBARU OUTBACK. DURING COLD WEATHIS, THE VEHICLE FAILED TO START. THE FAILURE OCCURRED EVER SINCE THE VEHICLE WAS PURCHASED ON APRIL 15, 2017. THE VEHICLE WAS TAKEN TO CAPITAL SUBARU (920 CAPITAL EXPRESSWAY AUTO MALL, SAN JOSE, CA 95136) ON THREE DIFFERENT OCCASIONS, BUT THEY WERE NOT ABLE TO REPLICATE THE FAILURE. THE MANUFACTURER WAS NOT NOTIFIED OF THE FAILURE. THE VEHICLE WAS NOT REPAIRED. THE APPROXIMATE FAILURE MILEAGE WAS 38,718.

268. On May 18, 2019, a 2017 Subaru Outback owner reported to NHTSA as follows:⁵⁹

IN TWO SEPARATE EVENTS THE CAR LOST POWER WHILE ACCELLORATING AT HIGHWAY SPEEDS TO MERGE INTO TRAFFIC FROM A STAND STILL. THE GAS PEDAL BECAME UNRESPONSIVE AND THE TRANMISSION STOPPED SHIFTING. IN THE FIRST INCIDENT THE ENGINE STALLED, AND IN THE SECOND IT SPUTTERED AND ALMOST DIED

⁵⁷ NHTSA Complaint 11302920.

⁵⁸ NHTSA Complaint 11277169.

⁵⁹ NHTSA Complaint 11208473.

DURING A HEAVY MERGE ON AN ON RAMP. NO DIAGNOSTIC CODES WERE THROWN, SO THE MANUFACTURER CLAIMS THISE IS NOTHING WRONG WITH THE CAR. IN THE FIRST INCIDENT THE CAR WAS LEAVING THE TOLL PLAZE ON THE DULLES GREENWAY HEAD TOWARD LEESBURG, VA. UNDER FULL ACELLERATION LEAVING THE TOLL PLAZA AND EFFECTIVELY DRIVING STRAIGHT, THE CAR STARTED SHUFTING ERRATICALLY, AND EVENTUALLY LOST POWER AND STALLED. IN THE SECOND INCIDENT, ABOUT TWO MONTHS LATER, THE CAR WAS ON A DECLINE ON-RAMP MERGING INTO HEAVY TRAFFIC ON RT-270N HEADING TOWARD FREDERICK, MD. THE CAR AGAIN STARTED TO SHIFT ERRATICALLY, THEN BEGAN TO STALL, BUT I WAS ABKE TO USE THE PADDLE SHIFTERS TO SHIFT THE "GEAR" OF THE CVT AND PREVENT STALLING. AFGER ABOUT 30 SECONDS THE CAR WAS OPERATING AS NORMAL. AGAIN, THE DEALER HAS NOT FOUND ANY DIAGNOSTIC CODES, AND INDICATES THISE IS NITHING WRONG WITH THE VEHICLE.

269. On November 7, 2019, a 2017 Subaru Impreza owner reported to NHTSA as follows:⁶⁰

TL* THE CONTACT OWNS A 2017 SUBARU IMPREZA. WHEN THE CONTACT ATTEMPTED TO ACCELERATE, THE VEHICLE LOST POWER. THE CONTACT WAS ABLE TO DRIVE THE VEHICLE TO HIS RESIDENCE. THISE WERE NO WARNING INDICATORS ILLUMINATED. THE VEHICLE WAS LATER TAKEN TO HISITAGE SUBARU OWINGS MILLS (9808 REISTERSTOWN RD, OWINGS MILLS, MD 21117, (888) 553-0026) WHISE THE TECHNICIAN REPLACED THE BATTERY; HOWEVER, THE FAILURE RECURRED. THE VEHICLE WAS NOT TAKEN BACK TO THE DEALER AND WAS NOT REPAIRED. THE VIN WAS INCLUDED IN NHTSA CAMPAIGN NUMBER: 19V743000 (ELECTRICAL SYSTEM). THE MANUFACTURER WAS NOT MADE OF THE FAILURE. THE FAILURE MILEAGE WAS APPROXIMATELY 9,500.

⁶⁰ NHTSA Complaint 11278649.

270. On January 24, 2018, a 2017 Subaru Impreza owner reported to NHTSA as follows:⁶¹

I WAS ABOUT TO MAKE A LEFT TURN AT THE LIGHT WHEN CAR SUDDENLY STALLED. BROUGHT IT TO LIBERTY SUBARU DEALERSHIP THE NEXT DAY AND TECH RELEASE IT AS SAFE TO DRIVE AFTER THEY CLAIMED TO FIX THE MAIN RELAY. A MINUTE AFTER I LEFT THE DEALERSHIP CAR STALLED AGAIN NEAR THE TRAIN TRACKS. **THE 2017 SUBARU IMPREZA IS HAZARDOUS, UNSAFE, AND LIFE THREATENING.** THIS TIME LIBERTY SUBARU SAID THEY HAVE TO REWIRE THE ENGINE. I AM NOT COMFORTABLE DRIVING THIS CAR WITH MY CHILDREN. IT IS NOT SAFE FOR ME, MY FAMILY, AND OTHIS DRIVERS.

271. On April 15, 2019, a 2018 Subaru Outback owner reported to NHTSA as follows:⁶²

WHEN I COME TO A STOP AND WAITING TO MAKE A LEFT TURN, THE VEHICLE WILL STALL WHEN I START TO TURN. **ENGINE IS STILL RUNNING, BUT THE CAR ESSENTIALLY STOPS IN MID TURN. THIS LEAVES ME EXPOSED TO A BROADSIDE COLLISION.** DEALER DOES NOT KNOW WHAT IS CAUSING IT AND IT DOES NOT HAPPEN EVERY TIME. IN THE LAST 1000 MILES IT HAS OCCURRED 4 TIMES. AFTER THE HESITATION, ABOUT 3 - 5 SECONDS, IT STARTS TO MOVE. IT HAS ALSO OCCURRED WHEN MOVING FROM ONE LANE TO ANOTHIS AFTER COMING TO A NEAR STOP DUE TO A CLOSED LANE IN THE ROAD.

272. On March 16, 2019, a 2018 Subaru Outback owner reported to NHTSA as follows:⁶³

FUEL DELIVERY PROBLEM. SOMETIMES WHEN STARTING UP FROM A STOP SIGN AND ALL OF A SUDDEN THISE IS NO POWER AND YOU HAVE TO HIT THE ACCELERATOR A COUPLE OF TIMES TO GET THE CAR TO RESPOND. SOMETIMES THIS OCCURS AT LOW SPEED

⁶¹ NHTSA Complaint 11064614.

⁶² NHTSA Complaint 11196562.

⁶³ NHTSA Complaint 11187279.

GOING LEFT AND ALL OF A SUDDEN THISE IS NO POWER AND YOU HAVE TO HIT THE ACCELERATOR A COUPLE OF TIMES TO GET IT TO RESPOND. THE ENGINE NEVER STALLS OUT. ON THE EXPRESSWAY IT DROPPED OUT OF CRUSE TWICE. I PULLED UP TO A STOP SIGN TO CROSS INTO TRAFFIC AND IT HAD POWER AT FIRST AND THEN NO POWER. ***I WAS THEN IN A PANIC MODE PRESSING ON THE ACCELERATOR AND FINALLY IT RESPONDED. THIS IS WHY I THINK IT IS SERIOUS.***

273. On February 1, 2019, a 2018 Subaru Outback owner reported to NHTSA as follows:⁶⁴

I WAS DRIVING THROUGH AN INTERSECTION WHEN THE ENGINE STALLED WITH 1/8TH OF A TANK OF GAS REMAINING. GAS LIGHT CAME ON ONLY A FEW MILES PRIOR. LUCKILY I WAS ABLE TO COAST INTO A GAS STATION. CAR STARTED AFTER TURNING OFF AND BACK ON. ONLY TOOK 16.9 GALLONS TO TOP OFF. THIS IS THE SECOND TIME THIS HAS HAPPENED. THE PREVIOUS TIME THE MILES TO EMPTY WAS SHOWING 50 WHEN IT STALLED. I WAS TOLD BY THE DEALERSHIP THAT THISE IS NO FIX FOR THE CURRENT RECALL.

274. On December 19, 2018, a 2018 Subaru Outback owner reported to NHTSA as follows:⁶⁵

CAR STALLED AND RAN OUT OF GAS WHEN THE SYSTEM SAID I HAD 20 MILES LEFT. I WAS 2 MILES FROM HOME/GAS STATION. THIS HAPPENED AT A STREET LIGHT ON A BUSY STREET. ***I HAD TO GET OUT AND PUSH THE CAR OUT OF THE WAY IN 5 LANES OF TRAFFIC.***

275. On September 22, 2018, a 2018 Subaru Impreza owner reported to NHTSA as follows:⁶⁶

THE ENGINE DIED WHILE COMING TO A RAPID STOP FROM ABOUT 35-40 MPH. ALL THE LIGHTS ON THE INSTRUMENT PANEL TURNED YELLOW. AFTER PUTTING

⁶⁴ NHTSA Complaint 11173593.

⁶⁵ NHTSA Complaint 11162588.

⁶⁶ NHTSA Complaint 11130767.

THE TRANSMISSION PARK THE ENGINE WOULD NOT RESTART. AFTER NUMEROUS ATTEMPTS, REMOVING AND REPLACING THE KEY, AND ABOUT 2 TO 3 MINUTES THE ENGINE DID START. I WAS UNABLE, AFTER A FEW ATTEMPTS, TO REPRODUCE THE PROBLEM. WE TOOK THE CAR TO THE DEALER. THEY STATED THAT THEY HAD NOT SEEN THIS PROBLEM. THEY DID, HOWEVER, PERFORM A SOFTWARE UPDATE IN THE HOPE THAT IT WOULD SOLVE THE PROBLEM.

276. On June 11, 2018, the owner of a 2018 Subaru Impreza filed the following complaint with NHTSA:⁶⁷

THE CAR HAS STALLED 3 TIMES WHILE DRIVING. AT A STOP SIGN, RED LIGHT AND AT A STOP SIGN. ***THE INCIDENT AT THE TRAFFIC LIGHT CAUSED THE VEHICLE TO START ROLLING BACKWARDS AND ALMOST HIT INTO ANOTHER VEHICLE.*** SUBARU CAN NOT FIND THE PROBLEM BUT ACKNOWLEDGES THE INCIDENTS OF STALLING. THE CAR IS NOT SAFE TO DRIVE AND WAS PURCHASED IN THE LATER HALF OF APRIL 2018.

2. Recalled Vehicles

277. There have also been innumerable reports about the safety risk of the Recalled Vehicles. For example, on February 7, 2020, a 2019 Subaru Ascent owner reported to NHTSA as follows:⁶⁸

VEHICLE LOSES POWER AFTER RAPID ACCELERATION ABOVE 45MPH. A WHOOSHING SOUND OCCURS AND - THEN ACCELERATION IS LIMITED. ALL WARNING LIGHTS FLASH INCLUDING "CHECK ENGINE." THIS HAS OCCURRED ONCE ABOUT A MONTH AGO AND DIAGNOSED AS A POORLY REPLACED GAS CAP—ALTHOUGH IT WAS ACTUALLY ON SECURELY. IT OCCURRED 2 WEEKS LATER 3 MORE TIMES WITHIN TWO DAYS. I BROUGHT IT IN WITH THE LIGHTS ON AND ISSUE STILL OCCURRING TO SUBARU PACIFIC. THEY CLEARED CODES AND TRIED TO RECREATE ISSUE WITHOUT SUCCESS. THEY RELEASED THE CAR BACK TO ME AFTER

⁶⁷ NHTSA Complaint 11101252.

⁶⁸ NHTSA Complaint 11307822.

CORPORATE DEFERRED TO THEM. UPON DRIVING OUT OF DEALERSHIP, THE SAME THING HAPPENED ONLY AFTER ACCELERATION ABOVE 18 MPH—ALL WARNING LIGHTS BACK ON AND SPUTTERING/JERKING/LOSS OF POWER. WHOOSHING SOUND. DEALER IS IN POSSESSION OF THE CAR AGAIN TO LOOK INTO IT. ALSO, THISE TENDS TO BE A GREY-BLUE HUE TO THE EXHAUST EACH TIME CAR STARTS.

278. On July 25, 2019, a 2019 Subaru Ascent owner reported to NHTSA as follows.⁶⁹

WHEN HOLDING SPEED CONSTANT BETWEEN APPROXIMATELY 20-35 MPH, OR UNDER VERY LIGHT ACCELERATION IN THIS RANGE, VEHICLE SEEMS TO JERK, SURGE, PULSE, OR SIMILAR. IT FEELS SIMILAR TO BEING IN THE CAR WITH SOMEONE LEARNING TO DRIVE A MANUAL TRANSMISSION

279. On September 12, 2019, a 2019 Subaru Impreza owner reported to NHTSA as follows:⁷⁰

CAR STOPPED RUNNING WHILE DRIVING DOWN THE STREET. AUTOMOBILE WAS TOWED TO DEALER YESTERDAY (9-11-19). DEALER, CALLED TODAY (9-12-19) SAID PROBLEM IS A BAD FUEL PUMP AND MAY TAKE UP TO A MONTH TO GET THE ORDERED PART DELIVERED AND INSTALLED. NEW VEHICLE PURCHASED APRIL, 2019 A LITTLE LESS THAN 2800 MILES ON ODOMETER.

280. Subaru's knowledge of the Fuel Pump Defect but failure to timely and adequately notify Class members and repair the defect is unconscionable and creates an unreasonable risk of injury or death to Plaintiffs, Class members, and others.

3. Other Subaru Models Not Included in Subaru's Initial Recall

281. Based on the NHTSA complaints, the Fuel Pump Defect is not only in pre-2019 Ascents, Outbacks, Imprezas, and Legacies; it is also in other Subaru models, including the Subaru

⁶⁹ NHTSA Complaint 11234998.

⁷⁰ NHTSA Complaint 11255104.

Forester. For example, on September 4, 2019, a 2019 Subaru Forester owner reported to NHTSA as follows:⁷¹

WHILE DRIVING AROUND 30MPH THE CAR WILL SOMETIMES HESITATE AND THEN LURCH IF THE GAS PEDAL IS VERY LIGHTLY PRESSED. SOMETIMES IT WILL DO IT AT HIGH SPEEDS AS WELL, AROUND 50MPH BUT NOT TYPICALLY AT FREEWAY SPEED. HAPPENS ON MOUNTAIN ROADS AND CITY STREETS. MOST NOTICEABLE WHEN KEEPING SPEED WITH A CAR AHEAD. WHEN PRESSING HARDER ON THE GAS PEDAL IT IS USUALLY NOT NOTICEABLE. WHEN DRIVING IN "SPORT" MODE OR WITH MANUAL PADDLE SHIFTERS SET AT 4TH GEAR OR LOWER IT DOES NOT HAPPEN. THIS IS A CVT SPORT MODEL. DROVE A LOANER OF THE SAME YEAR AND TRIM, WHICH SHOWED SIMILAR BEHAVIOR, ALTHOUGH LESS COMMON. SUBARU CLAIMS IT IS NORMAL BEHAVIOR.

282. On February 7, 2020, a 2019 Subaru Forester owner reported to NHTSA as follows:⁷²

THE CAR OCCASIONALLY ACTS LIKE IT GOING TO STALL, PRIMARILY WHEN TURNING LEFT AT TRAFFIC SIGNALS. THE ACCELERATOR HAS TO BE PUSHED HARD TO OVERCOME THE APPROXIMATELY 1- 1.5 SECOND DELAY BEFORE THE CAR STARTS TO ACCELERATE.

THIS HAS CAUSED NEAR COLLISIONS ON SEVERAL OCCASIONS.

THE ENGINE STOP BUTTON WAS ACTIVATED TO PREVENT ENGINE STOPPING AT CAR IDLE.

283. On April 12, 2019, a 2019 Subaru Forester owner reported to NHTSA the following:⁷³

IN OUR 2 WEEK OLD 2019 FORESTER, WE WERE DRIVING ON THE FREEWAY AT 65MPH AND FELT A SUDDEN JOLT

⁷¹ NHTSA Complaint 11253275.

⁷² NHTSA Complaint 11307743.

⁷³ NHTSA Complaint 11195742.

AND THE CAR SHUT OFF: THE LIGHTS ON THE DASHBOARD WENT OFF, THE HEADLIGHTS WENT OFF, THE TURN SIGNALS WOULD NOT WORK AND THE ACCELERATOR WASN'T WORKING. WE GUIDED THE CAR OFF THE FREEWAY AND SAT ON THE SIDE OF THE FREEWAY. THE DEALER'S MASTER MECHANIC CANNOT FIND ANY CODE THAT TELLS THEM WHAT IS WRONG SO THEY TELL US THISE IS NOTHING TO FIX. ***THIS IS OUTRAGEOUS. THIS WAS A LIFE-THREATENING EVENT SO WE DO NOT FEEL SAFE DRIVING THE CAR FOR OURSELVES AND OTHIS CARS ON THE FREEWAY. SUBARU IS NOT TAKING THIS SERIOUSLY.*** WE READ THISE HAVE BEEN OTHIS "CAR STALL" PROBLEMS SIMILAR TO OURS WITH FORESTERS FROM OTHIS YEARS.

284. On January 16, 2018, a 2018 Subaru Forester owner reported the following to NHTSA:⁷⁴

WHEN ATTEMPTING TO ACCELERATE TO MAKE A LEFT-HAND TURN THE CAR STOPPED - THE ENGINE WOULD NOT GET ABOVE IDLE, EVEN WHEN THE ACCELERATOR WAS PRESSED TO THE FLOOR. THE CAR STOPPED IN ONCOMING TRAFFIC. IT DID ACCELERATE AFTER COMPLETELY REMOVING PRESSURE FROM THE PEDAL AND PUSHING IT PARTIALLY DOWN AGAIN IT BEGAN TO PICK UP SPEED.

285. On September 5, 2018, the owner of a 2018 Subaru Forester filed the following complaint with NHTSA:⁷⁵

TL* THE CONTACT OWNS A 2018 SUBARU FORESTER. WHILE DRIVING APPROXIMATELY 80 MPH, THE VEHICLE SUDDENLY LOST ENGINE POWER. THE VEHICLE WAS COASTED TO AN EXIT RAMP. THE CONTACT STATED THAT THE ENGINE WAS STILL IDLING EXTREMELY LOW AND THE VEHICLE WAS TURNED OFF AND RESTARTED. RIMROCK SUBARU (324 S 24TH ST W, BILLINGS, MT 59102, (406) 651-5200) REPLACED THE FUEL PUMP AND FUEL PUMP CONTROL MODULE; HOWEVER, THE FAILURE CONTINUED. THE DEALER REFERRED THE CONTACT TO THE MANUFACTURER AND OFFERED A TRADE-IN FOR A

⁷⁴ NHTSA Complaint 11063153.

⁷⁵ NHTSA Complaint 11124519.

2018 SUBARU OUTBACK. THE MANUFACTURER WAS NOT CONTACTED. THE VEHICLE WAS NOT REPAIRED. THE APPROXIMATE FAILURE MILEAGE WAS 4,200.

286. On December 17, 2019, a 2017 Subaru Forester owner reported to NHTSA the following:⁷⁶

ON THREE SEPARATE OCCASIONS THUS FAR, WHILE DRIVING APPROXIMATELY 70 MPH ON INTERSTATE 93 IN MASSACHUSETTS AND NEW HAMPSHIRE, MY 2017 SUBARU FORESTER TOURING (WITH 21K MILES) LOST POWER AND COMPLETELY SHUTDOWN. ALL THREE TIMES, I WAS LUCKILY ABLE TO STEER THE VEHICLE TO SAFETY WHILE AVOIDING OTHIS MOTOR VEHICLES AND NEITHIS MYSELF, MY PASSENGERS NOR ANYONE ELSE AROUND US WAS HURT. WHEN THE VEHICLE DECIDES TO SHUTDOWN, IT FEELS LIKE THE CAR DROPS ITSELF INTO NEUTRAL, THE RPMS SHOOT UP TO ABOUT 4500-5000 AND ALL OF THE LIGHTS ON THE DASHBOARD LIGHT UP. THISE IS ABOUT A FIVE SECOND WINDOW TO STEER THE VEHICLE TO SAFETY FROM WHEN YOU FIRST DETECT THAT THE ISSUE IS OCCURRING. AFTER WAITING FOR ABOUT 45 MINUTES AFTER THE INCIDENT, I AM ABLE TO START THE CAR BACK UP AND DRIVE IT. THIS IS A SERIOUS SAFETY CONCERN OF MINE (AND IT IS TERRIFYING WHEN IT HAPPENS) AND I HAVE ALREADY CONTACTED SUBARU OF AMERICA ASKING FOR A SOLUTION.

I AM NOW CURRENTLY ONLY USING THE CAR ON SHORT TRIPS AND IF I HAVE TO GET ON THE HIGHWAY, I STICK TO THE RIGHT LANE AND DO NOT GO OVER 60 MPH.

287. On January 15, 2020, a 2015 Subaru Forester owner reported to NHTSA as follows:⁷⁷

TWO TIMES, WHILE DRIVING ON THE HIGHWAY AT ABOUT 65 MPH, MY CAR LOST THE ABILITY TO ACCELERATE. IT WAS AS THOUGH THE CAR SLIPPED INTO NEUTRAL. I PUSHED THE ACCELERATOR PEDAL AND THE RPM'S WOULD INCREASE, BUT THE CAR

⁷⁶ NHTSA Complaint 11289678.

⁷⁷ NHTSA Complaint 11299582.

WOULDN'T ACCELERATE. IT SIMPLY SLOWED DOWN. BOTH TIMES THE HIGHWAY WAS EMPTY ENOUGH THAT I WAS ABLE TO DRIFT INTO THE SHOULDER.

ONCE I PULLED OVER, I TURNED OFF THE CAR AND WAITED A FEW MINUTES. WHEN I TURNED IT BACK ON, THE CAR STARTED AND ACCELERATION WORKED AS NORMAL.

BOTH TIMES I BROUGHT IT TO A LOCAL SUBARU DEALERSHIP, AND AFTER RUNNING SOME TESTS SAID THEY COULDN'T FIND ANY ISSUES, AND COULDN'T HELP ME ANY FURTHER.

I'VE FOUND OTHER PEOPLE WHO HAVE EXPERIENCED VERY SIMILAR PROBLEMS, BUT IT SEEMS LIKE NO ONE HAS FOUND A SOLUTION.

288. On December 23, 2019, a 2015 Subaru Forester owner reported to NHTSA as follows:⁷⁸

WHILE DRIVING ON HIGHWAY AT 70MPH, THE VEHICLE SUDDENLY LOST POWER. THE ENGINE REVVED BUT NO RESPONSE, LIKE IT WAS IN NEUTRAL. THE ENGINE DID NOT COMPLETELY SHUT OFF, AND I WAS ABLE TO GET OVER TO THE SHOULDER. WHILE COASTING ON THE SHOULDER, THE CAR SPUTTERED AS IF IT WAS OUT OF GAS, BUT I HAD 1/4 TANK. IT THEN BEGAN TO RUN NORMALLY. I PULLED OFF TO A GAS STATION, FILLED IT UP, AND CONTINUED MY TRIP WITHOUT A PROBLEM. ***THE OCCURRENCE WAS VERY DANGEROUS ON A CONGESTED HIGHWAY.***

289. On November 18, 2019, a 2014 Subaru Forester owner reported to NHTSA as follows:⁷⁹

2014 SUBARU FORESTER STOPPED RUNNING WHILE DRIVING DOWN THE FREEWAY AT 70 MILES AN HOUR. ENGINE JUST QUITE RUNNING. ***LOST POWER. HAD TO PULL OVER IN MEDIAN. VERY SCARY. THIS IS SECOND TIME THIS HAS HAPPENED.*** DID NOT THROW A CODE

⁷⁸ NHTSA Complaint 11290811.

⁷⁹ NHTSA Complaint 11280804.

MESSAGE. DEALERSHIP CAN NOT DETECT PROBLEM. FIRST TIME WAS 4 YEARS AGO WHEN DRIVING AT 35 MPH ON CITY STREET COMING INTO TOWN. DID NOT THROW ERROR MESSAGE AT THAT TIME WAS TOLD TO DRIVE IT UNTIL IT DID IT AGAIN.

290. On August 17, 2019, a 2013 Subaru Forester owner reported to NHTSA as follows:⁸⁰

LACK OF POWER WHEN I TRY TO ACCELERATE. THE VEHICLE FEEL DOES'T GO WHEN I PRESS THE GAS FROM GETTING OUT OF STOP FOR A 10 SECONDS.

4. Affected 2020 Vehicles

291. Finally, even as the 2020 models had only been on the market for months when Subaru issues its initial recall, NHTSA complaints, like the fact that each of Denso's fuel pumps used defective materials, revealed what Defendants' already knew, that the Fuel Pump Defect is present in these models as well. For example, on April 21, 2020, a 2020 Subaru Outback owner reported to NHTSA as follows:⁸¹

WHEN DRIVING MY VEHICLE AROUND 50-70 IT WILL HESITATE AND ACTS LIKE IT WANTS TO STOP.

NO WARNING LIGHTS COME ON HAVE TAKING BACK TO THE DEALER. THEY COULDN'T GET IT TO DO THIS. THE VEHICLE IS NOT COLD WHEN THIS HAPPENS. IT CAN BE AFTER I'VE BEEN DRIVING FOR 30 MINUTES OR MORE. THIS HAPPENS ON MAIN ROADS AND HIGHWAYS.

292. The above complaints are just a small subset of the complaints submitted to NHTSA for sudden stalls and pump failures in the Affected Vehicles. The safety implications are obvious, as illustrated by the events described above and Subaru's eventual admission by its decision to issue a safety recall. And Defendants' neglect of the safety of the public is evidenced

⁸⁰ NHTSA Complaint 11244720.

⁸¹ NHTSA Complaint 11321843.

by the fact that, over a year later, Subaru finally expanded its recall to include some of the 2020 model year Affected Vehicles.

293. It cannot reasonably be questioned that Subaru is now, and was long before it first began selling Affected Vehicles, fully aware of the Fuel Pump Defect in the Affected Vehicles. Subaru has acquired that knowledge through at least: (1) NHTSA complaints; (2) warranty claims; (3) non-warranty repair records; (4) testing it claims to undertake in the development of new models; and (5) customer complaints to Subaru and its dealers.

294. For example, Subaru admitted in its Recall Report that it knew of the Fuel Pump Defect in July 2019, when it began receiving field reports of related issues. Subaru also received 245 warranty claims for just the fuel pumps made in Subaru's designated four-month time frame. However, it failed to act on that knowledge by issuing a recall until April 2020, eight months later. Even then, owners of the Recalled Vehicles would not be notified until an additional two months later.

295. Like all vehicle manufacturers, Subaru monitors consumer reports and sentiments about its products that appear on social media, blogs, review sites, enthusiast sites, and other internet resources. Subaru has toll-free numbers and email and other communication systems that are devoted to obtaining information (and complaints) from consumers about their products. Subaru has certainly received numerous complaints about the Fuel Pump Defect in Affected Vehicles, as evidenced, in part, by the NHTSA complaints that expressly indicate contact with Subaru directly and its dealers.

296. Subaru also receives technical information and reports from its dealers and service centers concerning warranty repairs, requests for warranty coverage, and safety complaints from vehicle owners.

E. Subaru Sells, Markets, and Advertises Subaru Brand Vehicles as Safe and Reliable

297. Subaru spends millions of dollars on advertising and focuses that advertising intently on claims of safety and reliability. Subaru knows and intends that consumers, including purchasers of Affected Vehicles, will buy their vehicles because they believe them to be safe and reliable.

298. Subaru's website amplifies this message and emphasizes the safety and dependability of Subaru vehicles, including the Affected Vehicles. Below is a screenshot from Subaru's website showing the portrayal of its vehicles as safe and dependable.



299. On its website, Subaru proclaims that “When you choose a Subaru, you’re not just choosing a car. You’re choosing a company with a lifetime commitment to protecting those you love.” At no point does Subaru disclose the Fuel Pump Defect or the safety risks created by the defect.

300. Subaru made similar representations regarding older model Affected Vehicles as well. In 2013, Subaru was touting the safety and reliability of its vehicles, including the Affected Vehicles; below is a snapshot of its website regarding safety and dependability:⁸²

⁸² <http://web.archive.org/web/20130807123214/http://www.subaru.com/why-subaru/liveloove.html?referralType=allvehicles> (last visited July 7, 2020).



301. Subaru continued this uniform and pervasive marketing message of safety and dependability throughout the Class period—from 2013 to the present.

302. Subaru also emphasized the safety and dependability in advertising for the Affected Vehicles. Subaru’s website contains the sales brochures for its current vehicles, as well as older models. These brochures consistently trumpet the safety and dependability of the Affected Vehicles. For example, below is a screenshot of a 2019 Subaru Outback sales brochure:⁸³



⁸³ https://www.subaru.com/content/dam/subaru/downloads/pdf/brochures/2019/Outback/MY19_OBK_Brochure.pdf (last visited July 7, 2020).

303. Subaru made identical statements regarding the 2019 Subaru Impreza, as illustrated below.⁸⁴

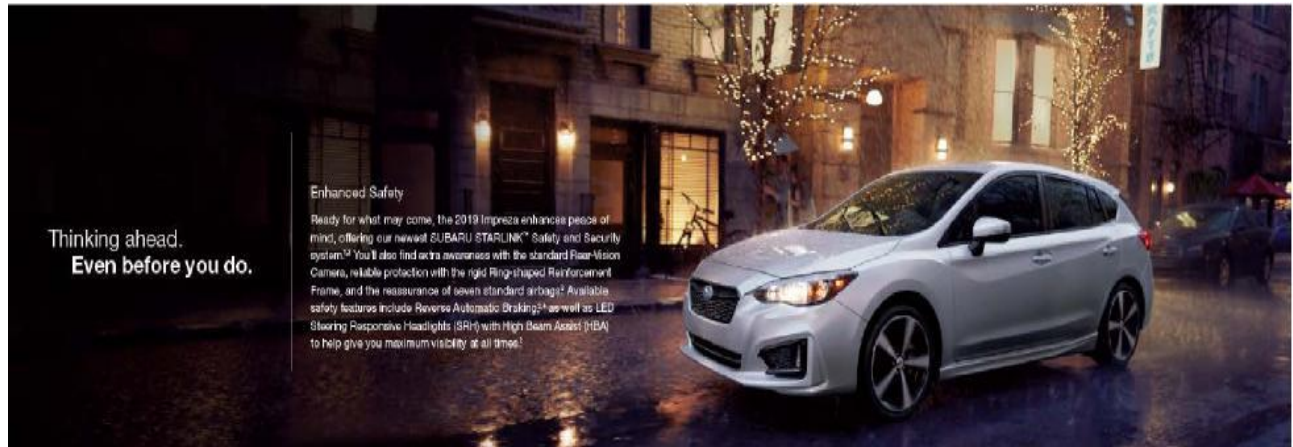

304. Subaru made similar statements regarding *all* Affected Vehicles. For example, below is a screenshot of a 2018 Subaru Impreza sales brochure:⁸⁵

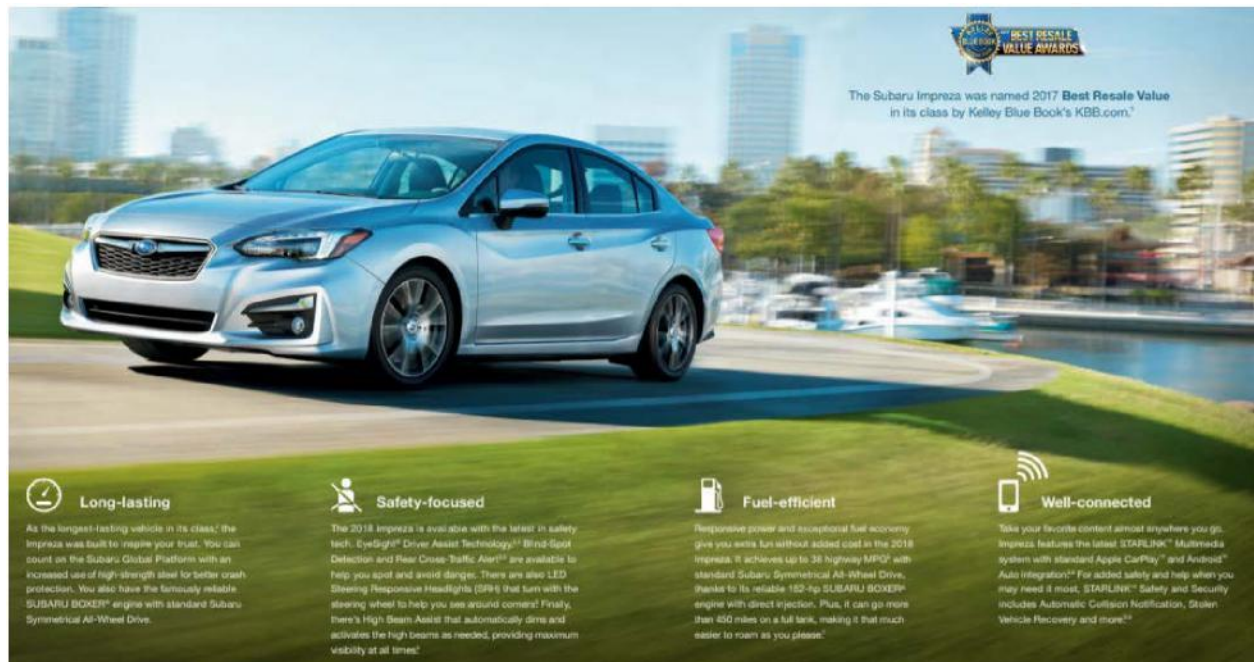

⁸⁴ https://www.subaru.com/content/dam/subaru/downloads/pdf/brochures/2019/Impreza/MY19_IMP_Brochure.pdf (last visited July 7, 2020).

⁸⁵ https://www.subaru.com/content/dam/subaru/downloads/pdf/brochures/2018/Impreza/2018_Subaru_Impreza.pdf (last visited July 7, 2020).

305. Below is a screenshot of a 2017 Subaru Outback sales brochure.⁸⁶

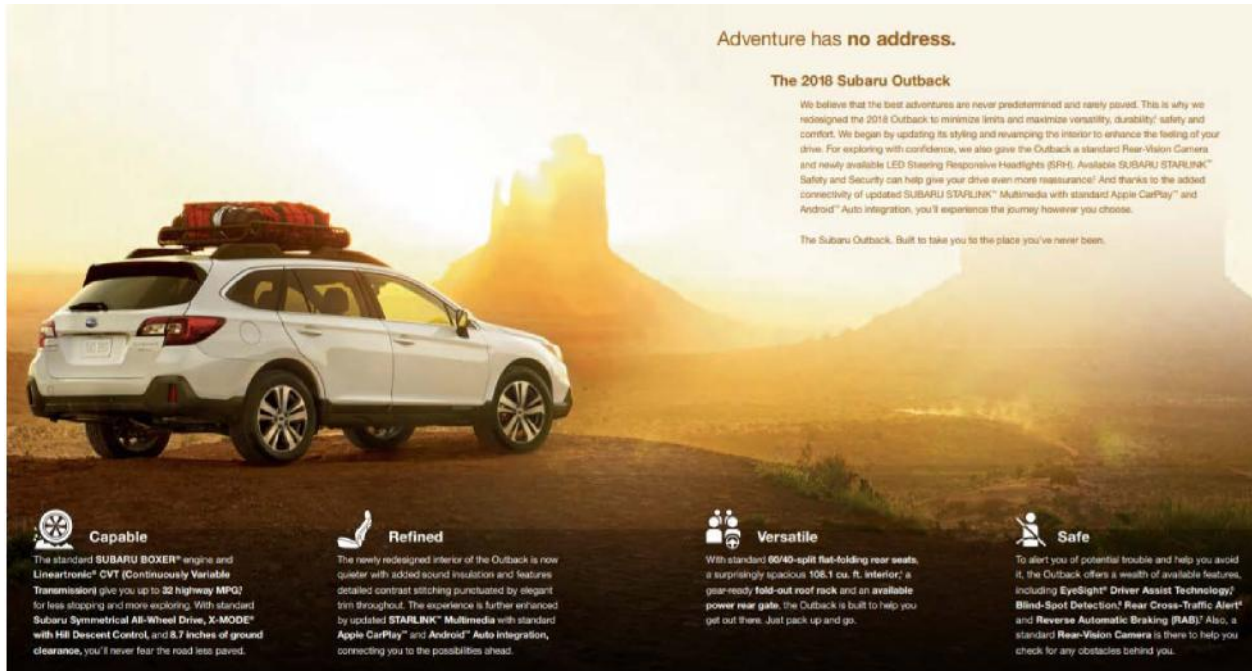

306. Below is a screenshot of a 2016 Subaru Forester sales brochure.⁸⁷



⁸⁶ https://www.subaru.com/content/dam/subaru/downloads/pdf/brochures/2018/Outback/2018_Subaru_Outback.pdf (last visited July 7, 2020).

⁸⁷ https://www.subaru.com/content/dam/subaru/downloads/pdf/brochures/2016/Forester/2016_Forester.pdf (last visited July 7, 2020).

307. Below is a screenshot of a 2015 Subaru Outback sales brochure.⁸⁸

Make every adventure count.

The 2015 Subaru Outback

The 2015 Outback helps you seize every free moment with a plethora of standard drop-everything-and-go features. Forget the aftermarket, every Outback comes standard with retractable roof cross bars with tie-downs, so you'll always arrive fully geared up. Also a standard feature, Subaru Symmetrical All-Wheel Drive featuring push-button X-MODE[®] with Hill Descent Control helps you conquer rougher terrain. When you want to spend more time adventuring and less time preparing, there's no other choice. With the Outback, versatility comes standard.

Efficient
The standard SUBARU BOXER[®] engine gives you up to 33 highway MPG, making it the most fuel-efficient midsize crossover in America!

Capable
Subaru Symmetrical All-Wheel Drive comes standard, as does X-MODE[®] with Hill Descent Control, and the best ground clearance of any midsize crossover. Never fear the road less traveled.

Versatile
With standard 60/40 reclining rear seats, a surprisingly spacious 100.1 cu. ft. interior, and an available power rear gate, the Outback is adventure-ready. Just pick up and go.

Safe
To alert you of potential trouble and help you avoid it, there are a wealth of available features, including the acclaimed EyeSight[®] driver assist technology, Blind Spot Detection and Rear Cross-Traffic Alert.

308. Below is a screenshot of a 2014 Subaru Legacy sales brochure.⁸⁹

Innovative Safety
A 2013 IIHS Top Safety Pick Plus and Top Safety Pick for eight years running (2006-2013), the Legacy is comprehensively engineered to help keep you safe on the road. Protecting the passenger area, there's a Ring-shaped Reinforcement Frame, six standard airbags* and the SUBARU BOXER[®] engine that's designed to push down and away from the passenger area in a collision. There's also EyeSight[®], an available driver-assist system that monitors the road ahead and if necessary will deliver a warning or even apply brakes to help your Legacy avoid an accident!

CVT
The Lineartronic[®] CVT can reduce the amount you spend on fuel by eliminating the need to shift, thereby preserving momentum with smooth continuous power. In automatic mode, it infinitely adjusts the transmission to match your immediate driving needs. Or use the paddle shifters and 6-speed manual mode for quick access to power and torque on the fly.

Suspension
Its tuned suspension enhances handling by reducing body roll. The double-wishbone rear suspension deflects the worst of the bumps without unsettling the chassis. With MacPherson struts up front, it's a light, yet supple ride that always leaves you feeling in touch and in control.

AWD Control
The traction and balance of Subaru Symmetrical All-Wheel Drive and the stability of the SUBARU BOXER[®] engine provide you with the responsiveness to seize the road and readiness to react to hazards. Legacy also comes standard with VDC electronic stability control, which can detect a loss of control and intervene to help keep you on your intended path.

Power
With a choice of a 173-hp 2.5-liter engine with available Lineartronic[®] CVT, or a 256-hp 3.6-liter engine with 5-speed automatic transmission, you are sure to find a Legacy that matches your performance needs.

Technology
Available features like dual-zone digital climate control help keep you comfortable, while a USB for your iPod[®], HD Radio[®], SiriusXM[®] Satellite Radio[®] and Bluetooth[®] hands-free connectivity keep you connected and entertained.

*The Safety Pick Plus award must meet other criteria for recipient consideration in the event of a distribution within the same performance class. IIHS award. Ratings based on crash test results. Always wear your seat belt. ©2013 Subaru. All rights reserved. All other trademarks are the property of their respective owners. Always use your seat belt. Always use proper driving techniques. The driver is always responsible for safe and lawful driving. System effectiveness depends on many factors.

⁸⁸ <https://cdn.dealereprocess.net/cdn/brochures/subaru/2015-outback.pdf> (last visited July 7, 2020).

⁸⁹ <https://cdn.dealereprocess.org/cdn/brochures/subaru/2014-legacy.pdf> (last visited July 7, 2020).

- a. Failed to disclose, at and after the time of purchase, lease, and/or service, the Fuel Pump Defect, despite its knowledge;
- b. Failed to disclose, at and after the time of purchase, lease, and/or service, that the Fuel Pumps were defective and not fit for their ordinary purpose, despite its knowledge; and
- c. Failed to disclose and actively concealed the existence and pervasiveness of the Fuel Pump Defect, despite its knowledge.

F. Denso Marketed Itself as Synonymous with Safety and Quality

314. Likewise, Denso claimed to put the safety of drivers first with an emphasis on quality. On its website, Denso represented that it is committed to making high-quality products that contribute to a higher quality of life for all people:⁹¹



⁹¹ <https://www.denso.com/global/en/about-us/our-strengths> (last visited December 1, 2020)

315. Denso also stated that it focuses on “Meticulous quality control,” and that “DENSO focuses on safety because cars carry people.”⁹²

Manufacturing

Innovative products and components can only be realized if they can be manufactured. At DENSO, our technicians and engineers painstakingly refine every detail of our manufacturing systems to enable the creation of the best technologies and products.



Meticulous quality control

DENSO focuses on safety because cars carry people. We were one of the first parts manufacturers to build our own test courses to evaluate our products, ensuring that people could confidently drive cars using our components. Our advanced test facilities are comparable with those of major carmakers and include such advances as high-low temperature wind tunnel laboratories and anechoic chambers that simulate the diverse conditions drivers encounter every day.

316. In its corporate brochure, Denso states that it seeks to create a world that is accident free, a goal belied by the Fuel Pump Defect and its response to that defect:⁹³

⁹² *Id.*

⁹³ https://www.denso.com/-/media/global/en/about-us/download/files/DENSO_brochure_en.pdf (last visited December 1, 2020).

Advanced Safety and Automated Driving

Provided Value

Realizing a safe society without accidents, and free and comfortable mobility

DENSO aims to create a mobile society without accidents and in which all people can move safely and with peace of mind. Guided by this aim, DENSO has developed reliable, high-quality safety technologies. By enhancing our long-cultivated sensing technologies as well as our AI and information technologies, we will further contribute to the development of automated driving. Maintaining our firm commitment to quality, which we have adopted since our founding, we will deliver genuine peace of mind for the future of the mobile society.



317. Similarly, Denso routinely touts its parts as high quality, reliable, and valuable. For example, this very phrase is the answer to the question “Why Denso?”⁹⁴

Home

WHY DENSO

Quality, Reliability and Value

Quality, Reliability and Value. At DENSO we've taken everything we have learned as an OE manufacturer and applied it to our aftermarket product lines. Every component that leaves our factories has been designed with precision, manufactured to OE standards and subjected to rigorous safety and performance tests.

DENSO factories are QS9000 and ISO9000 certified worldwide, just one of the many reasons why zero defects for parts produced in the millions is a reality for DENSO. A recipient of the prestigious Deming Award for quality in 1961, we've spent over five decades perfecting our technology and processes, a claim that few automotive manufacturers can make.

The OE-standard quality and reliability of DENSO aftermarket components add up to a tremendous value for our customers.

⁹⁴ <https://densoautoparts.com/why-denso.aspx> (last visited January 12, 2021).

G. Plaintiffs and Class Members Would Not Have Purchased or Leased, or Would Have Paid Less for, Affected Vehicles Had They Known of the Fuel Pump Defect

318. No owner or lessee of an Affected Vehicle would have purchased their vehicle, or at least would have paid less for their Affected Vehicle, had they known that the fuel delivery system might unexpectedly fail, or had they known that Subaru would fail to fix a known defect in the low-pressure fuel pump.

319. As a result of the Fuel Pump Defect in Affected Vehicles and the costs of repairs required to ameliorate it, Plaintiffs and all owners of Affected Vehicles (the “Class”) have suffered injury in fact, incurred damages, and have suffered harm as a result of Subaru’s acts and omissions. Plaintiffs and Class members seek remedies under the consumer protection statutes of the states in which they reside and/or purchased their Affected Vehicles, and also seek recovery for Subaru’s breach of express warranty, breach of implied warranty, breach of the duty of good faith and fair dealing, and fraudulent concealment.

320. Plaintiffs and each Class member suffered injury as they purchased their Affected Vehicle under the express and implied warranties that their vehicles would operate safely throughout the useful life of such vehicles. A vehicle containing the Fuel Pump Defect does not operate as warranted and for its intended purpose because it does not operate safely or reliably. In addition, an Affected Vehicle is worth less than a correctly operating/non-faulty Affected Vehicle.

H. Subaru Has Manipulated Its Warranty to Minimize Its Obligation to Fix the Fuel Pump Defect in Affected Vehicles

321. In connection with the sale of new vehicles, including the Affected Vehicles, Subaru provides a warranty for the lesser of three years or 36,000 miles.

322. The warranty states:

These warranties cover any repairs needed to correct defects in material or workmanship reported during the applicable warranty period and which occur under normal use

BASIC COVERAGE is 3 years or 36,000 miles, whichever comes first. Subject to the exclusions listed in this warranty, it covers the entire vehicle.

323. Subaru also offers a five-year 60,000-mile powertrain warranty. Subaru offers extended warranty options, including 8-years/120,000 miles and 10-years/10,000 miles.

324. In order to obtain repairs under the warranty, owners and lessees of covered vehicles are told by Subaru to present their vehicles to certified Subaru retailers.

325. Subaru is not honoring the plain language of its warranty agreement. Even when owners of Affected Vehicles have presented their cars to Subaru service centers and complained of issues traceable to the Fuel Pump Defect, Subaru has: (1) failed to notify them of the Fuel Pump Defect in their Affected Vehicles; and/or (2) notified them of the recall associated with the Fuel Pump Defect, but refused to repair the defect or provide alternative/replacement transportation that is not defective. Likewise, Affected Vehicle owners who do not complain of issues relating to the Fuel Pump Defect are never informed of the Fuel Pump Defect in Affected Vehicles, and are never offered a repair. Subaru has also failed to notify Affected Vehicle owners of the 2020 recall.

I. Allegations Establishing Agency Relationship Between Manufacturer Subaru and Subaru Dealerships

326. Upon information and belief, Subaru impliedly or expressly acknowledged that Subaru-authorized dealerships are its sales agents, the dealers have accepted that undertaking, Subaru has the ability to control authorized Subaru dealers, and Subaru acts as the principal in that relationship, as is shown by the following:

- i. Manufacturer Subaru can terminate the relationship with its dealers at will;
- ii. The relationships are indefinite;
- iii. Manufacturer Subaru is in the business of selling vehicles as are its dealers;
- iv. Manufacturer Subaru provides tools and resources for Subaru dealers to sell vehicles;

- v. Manufacturer Subaru supervises its dealers regularly;
- vi. Without Manufacturer Subaru, the relevant Subaru dealers would not exist;
- vii. Manufacturer Subaru requires the following of its dealers:
 - a. Reporting of sales;
 - b. Computer network connection with Manufacturer Subaru;
 - c. Training of dealers' sales and technical personnel;
 - d. Use of Manufacturer Subaru-supplied computer software;
 - e. Participation in Manufacturer Subaru's training programs;
 - f. Establishment and maintenance of service departments in Subaru dealerships;
 - g. Certify Subaru pre-owned vehicles;
 - h. Reporting to Manufacturer Subaru with respect to the vehicle delivery, including reporting Class members' names, addresses, preferred titles, primary and business phone numbers, e-mail addresses, vehicle VIN numbers, delivery date, type of sale, lease/finance terms, factory incentive coding, if applicable, vehicles' odometer readings, extended service contract sale designations, if any, and names of delivering dealership employees; and
 - i. Displaying Manufacturer Subaru logos on signs, literature, products, and brochures within Subaru dealerships.
- viii. Dealerships bind Manufacturer Subaru with respect to:
 - a. Warranty repairs on the vehicles the dealers sell; and
 - b. Issuing service contracts administered by Manufacturer Subaru.
- ix. Manufacturer Subaru further exercises control over its dealers with respect to:
 - a. Financial incentives given to Subaru dealer employees;
 - b. Locations of dealers;
 - c. Testing and certification of dealership personnel to ensure compliance with Manufacturer Subaru's policies and procedures; and

- d. Customer satisfaction surveys, pursuant to which Manufacturer Subaru allocates the number of Subaru cars to each dealer, thereby directly controlling dealership profits.
- x. Subaru dealers sell Subaru vehicles on Manufacturer Subaru's behalf, pursuant to a "floor plan," and Manufacturer Subaru does not receive payment for its cars until the dealerships sell them.
- xi. Dealerships bear Subaru's brand names, use Subaru's logos in advertising and on warranty repair orders, post Subaru-brand signs for the public to see, and enjoy a franchise to sell Manufacturer Subaru's products, including the Affected Vehicles.
- xii. Manufacturer Subaru requires Subaru dealers to follow the rules and policies of Manufacturer Subaru in conducting all aspects of dealer business, including the delivery of Manufacturer Subaru's warranties described above, and the servicing of defective vehicles such as the Affected Vehicles.
- xiii. Manufacturer Subaru requires its dealers to post Subaru's brand names, logos, and signs at dealer locations, including dealer service departments, and to identify themselves and to the public as authorized Subaru dealers and servicing outlets for Manufacturer Subaru cars.
- xiv. Manufacturer Subaru requires its dealers to use service and repair forms containing Manufacturer Subaru's brand names and logos.
- xv. Manufacturer Subaru requires Subaru dealers to perform Manufacturer Subaru's warranty diagnoses and repairs, and to do the diagnoses and repairs according to the procedures and policies set forth in writing by Manufacturer Subaru.
- xvi. Manufacturer Subaru requires Subaru dealers to use parts and tools either provided by Manufacturer Subaru, or approved by Manufacturer Subaru, and to inform Subaru when dealers discover that unauthorized parts have been installed on one of Manufacturer Subaru's vehicles.
- xvii. Manufacturer Subaru requires dealers' service and repair employees to be trained by Subaru in the methods of repair of Subaru-brand vehicles.
- xviii. Manufacturer Subaru audits Subaru dealerships' sales and service departments and directly contacts the customers of said dealers to determine their level of satisfaction with the sale and repair services provided by the dealers; dealers are then granted financial incentives or reprimanded depending on the level of satisfaction.

- xix. Manufacturer Subaru requires its dealers to provide Subaru with monthly statements and records pertaining, in part, to dealers' sales and servicing of Manufacturer Subaru's vehicles.
- xx. Manufacturer Subaru provides technical service bulletins and messages to its dealers detailing chronic defects present in product lines, and repair procedures to be followed for chronic defects.
- xxi. Manufacturer Subaru provides its dealers with specially trained service and repair consultants with whom dealers are required by Manufacturer Subaru to consult when dealers are unable to correct a vehicle defect on their own.
- xxii. Manufacturer Subaru requires Subaru-brand vehicle owners to go to authorized Subaru dealers to obtain servicing under Subaru warranties.
- xxiii. Subaru dealers are required to notify Manufacturer Subaru whenever a car is sold or put into warranty service.

VI. TOLLING OF THE STATUTE OF LIMITATIONS

A. Discovery Rule Tolling

327. Class members had no way of knowing about Subaru's deception with respect to the Fuel Pump Defect in the Affected Vehicles.

328. Within the time period of any applicable statutes of limitation, Plaintiffs and members of the proposed classes could not have discovered through the exercise of reasonable diligence that Subaru was concealing the Fuel Pump Defect in the Affected Vehicles and misrepresenting the safety, quality, and reliability of the Affected Vehicles.

329. Plaintiffs and the other Class members did not discover, and did not know of, facts that would have caused a reasonable person to suspect that Subaru did not report information within their knowledge to federal and state authorities, the dealerships, or consumers; nor would a reasonable and diligent investigation have disclosed that Subaru had concealed information about the true nature of the Fuel Pump Defect in the Affected Vehicles, which was discovered by Plaintiffs only shortly before this action was filed. Nor, in any event, would such an investigation

on the part of Plaintiffs and other Class members have disclosed that Subaru valued profits over the safety of its customers, their friends and family, and innocent bystanders.

330. For these reasons, all applicable statutes of limitation have been tolled by operation of the discovery rule with respect to the claims asserted herein.

B. Fraudulent Concealment Tolling

331. All applicable statutes of limitation have also been tolled by Subaru's knowing and active fraudulent concealment and denial of the facts alleged herein throughout the time period relevant to this action.

332. Instead of disclosing the existence of the Fuel Pump Defect, Subaru falsely represented that the Affected Vehicles were safe, dependable, reliable, and of high quality.

C. Estoppel

333. Subaru was under a continuous duty to disclose to Plaintiffs and the other Class members the true character, quality, and nature of the fuel delivery system in the Affected Vehicles.

334. Subaru knowingly, affirmatively, and actively concealed or recklessly disregarded the true nature, quality, and character of the fuel delivery system in the Affected Vehicles.

335. Based on the foregoing, Subaru is estopped from relying on any statutes of limitations in defense of this action.

VII. CHOICE OF LAW ALLEGATIONS

336. Because this Complaint is brought in New Jersey, New Jersey's choice of law regime governs the state law allegations in this Complaint. Under New Jersey's choice of law rules, New Jersey law applies to the claims of all Class members, regardless of their state of residence or state of purchase.

337. Because Subaru is headquartered in New Jersey, and made all decisions related to these claims in this State, New Jersey has a substantial connection to, and materially greater interest in, the rights, interests, and policies involved in this action compared to any other state. Application of New Jersey law to the claims of all Class members would accordingly not be arbitrary or unfair.

VIII. CLASS ALLEGATIONS

338. Pursuant to Fed. R. Civ. P. 23(b)(2) and (b)(3), as applicable, and (c)(4), Plaintiffs seek certification of a Class (“the Class”) defined as follows:

All persons or entities in the United States who owned and/or leased a Subaru vehicle with the Denso low-pressure fuel pump, including with part number prefix 42022-.

339. In addition or as an alternative to the Nationwide Class, and pursuant to Federal Rule of Civil Procedure Rule 23(c)(5) and/or the respective state statute(s), Plaintiffs may seek to represent all members of the following Subclass of the Class, as well as any subclasses or issue classes as Plaintiffs may propose and/or this Court may designate at the time of class certification, including but not limited to claims under the consumer protection and unfair and deceptive trade practices statutes of each of the jurisdictions below in each of those jurisdictions:

All persons or entities who owned and/or leased a Subaru vehicle with the Denso low-pressure fuel pump, including with part number prefix 42022- in the United States and its territories since January 1, 2006 to the present within Alabama, Alaska, Arizona, Arkansas, California, Colorado, Connecticut, Delaware, District of Columbia, Florida, Georgia, Idaho, Illinois, Indiana, Iowa, Kansas, Kentucky, Louisiana, Maine, Maryland, Massachusetts, Michigan, Minnesota, Missouri, Montana, Nebraska, Nevada, New Hampshire, New Jersey, New Mexico, New York, North Carolina, Ohio, Oklahoma, Oregon, Pennsylvania, Rhode Island, South Carolina, South Dakota, Tennessee, Texas, Utah, Vermont, Virginia, Washington, West Virginia, and Wisconsin.

340. Plaintiffs reserve their rights before the Court determines whether certification is appropriate to redefine the proposed class, or to propose subclasses, if necessary or alternatively, including but not limited to state subclasses (*i.e.*, the Alabama Subclass, the Washington Subclass, etc.) and/or entity subclasses.

341. Collectively, unless otherwise so stated, the above-defined classes and subclasses are referred to herein as the “Class.”

342. Excluded from the Classes are individuals who have personal injury claims resulting from the fuel delivery system in the Affected Vehicles. Also excluded from the Classes is Subaru and its subsidiaries and affiliates; all persons who make a timely election to be excluded from the Classes; governmental entities; and the Judge to whom this case is assigned and his/her immediate family. Plaintiffs reserve the right to revise the definition of any of the Classes based upon information learned through discovery.

343. Certification of Plaintiffs’ claims for classwide treatment is appropriate because Plaintiffs can prove the elements of their claims on a classwide basis using the same evidence as would be used to prove those elements in individual actions alleging the same claims.

344. This action has been brought and may be properly maintained on behalf of each of the Classes proposed herein under Federal Rule of Civil Procedure 23.

345. **Numerosity**. Federal Rule of Civil Procedure 23(a)(1): The members of each of the Classes are so numerous and geographically dispersed that individual joinder of all Class members is impracticable. While Plaintiffs are informed and believe—based on publicly available sales data for the Affected Vehicles—that there are at least 200,000 members of the Classes, the precise number of members of the Classes is unknown to Plaintiffs but may be ascertained from Subaru’s books and records, as well as the recall reports that Subaru has

submitted to NHTSA. Members of the Classes may be notified of the pendency of this action by recognized, Court-approved notice dissemination methods, which may include U.S. Mail, electronic mail, Internet postings, and/or published notice.

346. **Commonality and Predominance**: Federal Rule of Civil Procedure 23(a)(2) & (b)(3): This action involves common questions of law and fact which predominate over any questions affecting individual members of the Classes, including, without limitation:

- a. Whether Subaru engaged in the conduct alleged herein;
- b. Whether Subaru designed, advertised, marketed, distributed, leased, sold, or otherwise placed the Affected Vehicles into the stream of commerce in the United States;
- c. Whether the Affected Vehicles contain a defect in their fuel delivery system and if so, whether it is a safety defect;
- d. Whether Subaru knew about the defect in the fuel delivery system of the Affected Vehicles and, if so, how long Subaru has known;
- e. When Subaru discovered the Fuel Pump Defect in the Affected Vehicles, and what, if anything, they did in response;
- f. Whether Subaru has sought to minimize their warranty expenses by refusing to repair the Fuel Pump Defect in the Affected Vehicles;
- g. Whether Subaru engaged in breach of contract and fraudulent concealment as asserted herein;
- h. Whether Plaintiffs and the other Class members overpaid for their Affected Vehicles;
- i. Whether Plaintiffs experienced out-of-pocket losses from replacing parts as a result of the Fuel Pump Defect, and if so, how much; and
- j. Whether Plaintiffs and the other members of the Classes are entitled to damages and other monetary relief and, if so, in what amount.

347. **Typicality**: Federal Rule of Civil Procedure 23(a)(3): Plaintiffs' claims are typical of the other members of the Classes' claims because, among other things, all members of the Classes were comparably injured through Subaru's wrongful conduct as described above.

348. **Adequacy**: Federal Rule of Civil Procedure 23(a)(4): Plaintiffs are adequate Class representatives because their interests do not conflict with the interests of the other members of the Classes they seek to represent; Plaintiffs have retained counsel competent and experienced in complex class action litigation; and Plaintiffs intend to prosecute this action vigorously. The Classes' interests will be fairly and adequately protected by Plaintiffs and their counsel.

349. **Declaratory Relief**: Federal Rule of Civil Procedure 23(b)(2): Subaru has acted or refused to act on grounds generally applicable to Plaintiffs and the other members of the Classes, thereby making appropriate declaratory relief, with respect to each Class as a whole.

350. **Superiority**: Federal Rule of Civil Procedure 23(b)(3): A class action is superior to any other available means for the fair and efficient adjudication of this controversy and no unusual difficulties are likely to be encountered in the management of this class action. The damages or other financial detriment suffered by Plaintiffs and the other members of the Classes are relatively small compared to the burden and expense that would be required to individually litigate their claims against Subaru, so it would be impracticable for the members of the Classes to individually seek redress for Subaru's wrongful conduct. Even if members of the Classes could afford individual litigation, the court system could not. Individualized litigation creates a potential for inconsistent or contradictory judgments and increases the delay and expense to all parties and the court system. By contrast, the class action device presents far fewer management difficulties and provides the benefits of single adjudication, economy of scale, and comprehensive supervision by a single court.

A. Claims Brought on Behalf of the Nationwide Class

COUNT I

**VIOLATIONS OF 15 U.S.C. § 2301, *ET SEQ.*
THE MAGNUSON-MOSS WARRANTY ACT
(As to Subaru)**

351. Plaintiffs reallege and incorporate by reference all paragraphs as though fully set forth herein.

352. Plaintiffs bring this cause of action for themselves and on behalf of the Class. In the alternative, Plaintiffs bring this claim on behalf of each state subclass under the law of each state in which Class or subclass members owned and/or leased a Subaru vehicle with the Denso low-pressure fuel pump, including with part number prefix 42022-.⁹⁵

353. Plaintiffs are each a “consumer” within the meaning of the Magnuson-Moss Warranty Act, 15 U.S.C. § 2301(3).

354. Subaru is a “supplier” and “warrantor” within the meaning of the Magnuson-Moss Warranty Act, 15 U.S.C. § 2301(4)–(5).

355. The Affected Vehicles are “consumer products” within the meaning of the Magnuson-Moss Warranty Act, 15 U.S.C. § 2301(1).

356. 15 U.S.C. § 2301(d)(1) provides a cause of action for any consumer who is damaged by the failure of a warrantor to comply with a written or implied warranty.

357. Subaru’s written warranty within the meaning of the Magnuson-Moss Warranty Act, 15 U.S.C. § 2301(6). The Affected Vehicles’ implied warranties are covered under 15 U.S.C. § 2301(7).

358. Subaru breached these warranties, as described in more detail above. Without limitation, the Affected Vehicles are equipped with a defective fuel delivery system that fails to function as expected, and can cause loss of power and stalls, leading to vehicle accidents and

⁹⁵ Accordingly, “Class members” or “absent Class members” also refers to the absent members of any Subclass.

collisions. The Affected Vehicles share a common design defect in that the fuel delivery system fails to operate as represented by Subaru.

359. Plaintiffs and the other Class members have had sufficient direct dealings with either Subaru or its agents (e.g., dealerships and technical support) to establish privity of contract between Subaru on one hand, and Plaintiffs and each of the other Class members on the other hand. Nonetheless, privity is not required here because Plaintiffs and each of the other Class members are intended third-party beneficiaries of contracts between Subaru and its dealers, and specifically, of Subaru's implied warranties. The dealers were not intended to be the ultimate consumers of the Affected Vehicles and have no rights under the warranty agreements provided with the Affected Vehicles; the warranty agreements were designed for and intended to benefit the consumers only.

360. Affording Subaru a reasonable opportunity to cure its breach of written warranties would be unnecessary and futile here.

361. At the time of sale or lease of each Affected Vehicle, Subaru knew, should have known, or was reckless in not knowing of its misrepresentations and omissions concerning the Affected Vehicles' inability to perform as warranted, but nonetheless failed to rectify the situation and/or disclose the defective design. Subaru has expressly admitted the existence of the Fuel Pump Defect and that it is a safety defect, but notwithstanding its recall of nearly 200,000 Affected Vehicles, it has not offered a fix or indicated that a fix is available. Under the circumstances, the remedies available under any informal settlement procedure would be inadequate and any requirement that Plaintiffs resort to an informal dispute resolution procedure and/or afford Subaru a reasonable opportunity to cure its breach of warranties is excused and thereby deemed satisfied.

362. Plaintiffs and the other Class members would suffer economic hardship if they returned their Affected Vehicles but did not receive the return of all payments made by them. Because Subaru is refusing to acknowledge any revocation of acceptance and return immediately any payments made, Plaintiffs and the other Class members have not re-accepted their Affected Vehicles by retaining them.

363. The amount in controversy of Plaintiffs' individual claims meets or exceeds the sum of \$25. The amount in controversy of this action exceeds the sum of \$50,000, exclusive of interest and costs, computed on the basis of all claims to be determined in this lawsuit.

364. Plaintiffs, individually and on behalf of the other Class members, seek all damages permitted by law, including diminution in value of the Affected Vehicles, in an amount to be proven at trial.

COUNT II

FRAUDULENT CONCEALMENT/OMISSION (BASED ON COMMON LAW) (As to all Defendants)

365. Plaintiffs restate and reallege, and incorporate herein by reference, the preceding paragraphs as if fully set forth herein and further allege as follows:

366. Plaintiffs bring this Count on behalf of themselves and the Nationwide Class or, in the alternative, on behalf of the State Subclasses.

367. Defendants intentionally concealed that the Affected Vehicles contained fuel pumps that are defective, that the fuel pumps were not of the high quality represented or suitable for their ordinary purpose, that the Fuel Pump Defect rendered the Affected Vehicles unsafe and unreliable to operate, and that Defendants acted with reckless disregard for the truth and denied

Plaintiffs and the other Class members information that is highly relevant to their purchasing decision.

368. Subaru further affirmatively misrepresented to Plaintiffs and the public in advertising and other forms of communication, including standard and uniform material provided with each Affected Vehicle and on its website, that the Affected Vehicles it was selling had no significant defects, that the Affected Vehicles were safe, reliable, and of high quality, and would perform and operate in a safe manner.

369. Subaru knew about the defect in the Affected Vehicles when these representations were made.

370. Denso repeatedly represented the quality and standards of its fuel pumps to the public.

371. Denso knew about the Fuel Pump Defect when these representations were made.

372. The Affected Vehicles purchased by Plaintiffs and the other Class members contained defective fuel pumps.

373. The truth about the defective Affected Vehicles was known only to Defendants; Plaintiffs and the other Class members did not know of these facts and Defendants actively concealed these facts from Plaintiffs and Class members.

374. Plaintiffs and the other Class members reasonably relied upon Defendant's deception. They had no way of knowing that their vehicles contained defective fuel pumps, which Defendants concealed. As consumers, Plaintiffs and Class members did not, and could not, unravel Defendants' deception on their own. Rather, Defendant intended to deceive Plaintiffs and Class members by concealing the true facts about the Affected Vehicles and the fuel pumps.

375. Defendants' false representations and omissions were material to consumers because they concerned the safety of the Affected Vehicles, which played a significant role in the value of the Affected Vehicles.

376. Defendants had a duty to disclose the Fuel Pump Defect, the defective design of the fuel pump and impeller used, that the Fuel Pump Defect rendered the Affected Vehicles unsafe and unreliable to operate, and violations with respect to the Affected Vehicles because they concerned the safety of the Affected Vehicles, the details of the true facts were known and/or accessible only to Defendants, because Defendants had exclusive knowledge as to such facts, and because Defendants knew these facts were not known to or reasonably discoverable by Plaintiffs or Class members.

377. Defendants also had a duty to disclose because it made material representations about the safety and reliability of the Affected Vehicles and quality of the vehicles' engine and fuel pump, without telling consumers that the Affected Vehicles had a fundamental system defect that would affect the safety, quality, and reliability of the Affected Vehicles. Defendant's partial disclosures were misleading, deceptive, and incomplete because they failed to inform consumers of the additional facts regarding the Fuel Pump Defect as set forth herein. These omitted and concealed facts were material because they directly impact the safety and value of the Affected Vehicles purchased by Plaintiffs and Class members.

378. Having volunteered to provide information to Plaintiffs and Class members, Subaru had the duty to disclose not just the partial truth, but the entire truth. These omitted and concealed facts were material because they directly impact the value of the Affected Vehicles purchased or leased by Plaintiffs and Class members. Whether a manufacturer's products are defective and unsafe to operate, and whether that manufacturer tells the truth with respect to such defect and

safety are material concerns to a consumer. Subaru represented to Plaintiffs and Class members that they were purchasing or leasing safe and reliable vehicles, when in fact, Subaru knew they were purchasing or leasing defective vehicles with the Fuel Pump Defect that causes engine failure and increased risk of crash.

379. As alleged in this Complaint, at all relevant times, Subaru, with Denso's knowledge and complicity, has held out the Affected Vehicles to be safe and reliable and that the fuel pump was not defective. Defendants disclosed certain details about the engine and fuel pump, but nonetheless intentionally failed to disclose the important facts that the Denso impeller used an unsuitable material for its intended use; that the impeller's material had an inferior long-term dimensional stability (it deforms, swells and changes shape), resulting in premature and unexpected failure due to component distortion and the resultant swelling induced friction; that the impeller's material had inadequate heat resistance, potentially resulting in dimensional distortion and loss of structural integrity when exposed to high temperatures or repeated temperature cycling (i.e., the intended and repeated temperature changes of operation); that the impeller's material was highly porous, which may lead not only to absorption of gasoline, but also fuel contaminants may become lodged in the impeller's pores, leading to Fuel Pump failure; and that when the plastic used absorbed liquid, such as gasoline, the plastics' intended dimensions changed—making other disclosures about the engine and fuel pump deceptive.

380. Defendants actively concealed and/or suppressed these material facts, in whole or in part, to pad and protect profits and to avoid the perception that Subaru's vehicles were not safe to operate, which perception would hurt the brand's image and cost Defendants money, and it did so at the expense of Plaintiffs and Class members.

381. Defendants have still not made full and adequate disclosures and continues to defraud Plaintiffs and Class members by concealing material information regarding the Fuel Pump Defect in the Affected Vehicles.

382. Plaintiffs and Class members were unaware of the omitted material facts referenced herein, and they would not have acted as they did if they had known of the concealed and/or suppressed facts, in that they would not have purchased or paid as much for the Affected Vehicles with the Fuel Pump Defect, and/or would have taken other affirmative steps in light of the information concealed from them. Plaintiffs' and Class members' actions were justified. Subaru was in exclusive control of the material facts, and such facts were not generally known to the public, Plaintiffs, or Class members.

383. Because of the concealment and/or suppression of facts, Plaintiffs and Class members sustained damage because they own Affected Vehicles that are diminished in value as a result of Defendants' concealment of the true safety and quality of the Affected Vehicles. Had Plaintiffs and Class members been aware of the Fuel Pump Defect, and Defendants' disregard for the truth, Plaintiffs and Class members would have paid less for their Affected Vehicles or would not have purchased them at all.

384. The value of Plaintiffs' and Class members' Affected Vehicles has diminished as a result of Subaru's fraudulent concealment of the Fuel Pump Defect, which has made any reasonable consumer reluctant to purchase an Affected Vehicle, let alone pay what otherwise would have been fair market value for the Affected Vehicle.

385. Accordingly, Defendants are liable to Plaintiffs and Class members for damages in an amount to be proven at trial.

386. Defendants' acts were done wantonly, maliciously, oppressively, deliberately, with intent to defraud, and in reckless disregard of Plaintiffs' and Class members' rights, in order to enrich Defendants. Defendants' conduct warrants an assessment of punitive damages in an amount sufficient to deter such conduct in the future, which amount is to be determined according to proof.

COUNT III

BREACH OF CONTRACT (COMMON LAW) (As to Subaru)

387. Plaintiffs restate and reallege, and incorporate herein by reference, the preceding paragraphs as if fully set forth herein and further allege as follows.

388. Plaintiffs assert this Count on behalf of themselves and the Nationwide Class or, in the alternative, on behalf of the state Subclasses.

389. Subaru's misrepresentations and omissions alleged herein, including but not limited to, Subaru's concealment and suppression of material facts concerning the Affected Vehicles, including the reliability and durability of the fuel delivery system, caused Plaintiffs and the other Class members to make their purchases or leases of their Affected Vehicles.

390. Absent those misrepresentations and omissions, Plaintiffs and the other Class members would not have purchased or leased these Affected Vehicles, would not have purchased or leased these Affected Vehicles at the prices they paid, and/or would have purchased or leased different vehicles that did not contain the Defective Fuel Pump. Accordingly, Plaintiffs and other Class members overpaid for their Affected Vehicles and did not receive the benefit of their bargain.

391. Each and every sale or lease of an Affected Vehicle constitutes a contract between Subaru and the purchaser or lessee. Subaru breached these contracts by selling or leasing to Plaintiffs and the other Class members defective Affected Vehicles and by misrepresenting or

failing to disclose material facts concerning the safety, durability, performance, and quality of the Affected Vehicles.

392. As a direct and proximate result of Subaru's breach of contract, Plaintiffs and other Class members have been damaged in an amount to be proven at trial, which shall include, but is not limited to, all compensatory damages, incidental and consequential damages, and other damages allowed by law.

COUNT IV

STRICT PRODUCT LIABILITY

(As to all Defendants)

393. Plaintiffs restate and reallege, and incorporate herein by reference, the preceding paragraphs as if fully set forth herein and further allege as follows.

394. Plaintiffs assert this Count on behalf of themselves and the Nationwide Class or, in the alternative, on behalf of the state Subclasses.

395. By placing unreasonably dangerous products in the stream of commerce, Defendants are strictly liable.

396. Defendants are strictly liable for designing, engineering, testing, validating, manufacturing, and placing into the stream of commerce unreasonably dangerous fuel pump and the Affected Vehicles with the unreasonably dangerous fuel pumps.

397. The Affected Vehicles, including the fuel pumps, are being used in an intended and/or foreseeable manner. Plaintiff and the other Class members have not misused or materially altered the Affected Vehicles or fuel pumps which are in the same or substantially similar condition as they were at the time of purchase/lease.

398. The Affected Vehicles and fuel pumps are unreasonably dangerous and defective because they were designed, engineered, tested, validated, manufactured, and placed in the stream

of commerce with the Fuel Pump Defect that can cause Affected Vehicles to suddenly and unexpectedly stall or lose engine power.

399. The Fuel Pump Defect causes an unreasonably dangerous condition when Affected Vehicles are used for their intended and foreseeable purpose of providing safe and reliable transportation and places Plaintiff, and other Class members, and others on the road at an unreasonable and substantial risk for injury or death.

400. Defendants were aware of feasible alternative designs which would minimize or eliminate the Fuel Pump Defect and the risk it poses. Such alternative designs were known and available when the Affected Vehicles and fuel pumps were designed, engineered, tested, validated, manufactured, and placed in the stream of commerce.

401. Defendants failed to design, test, validate, manufacture, and place in the stream of commerce Affected Vehicles and a fuel pump that are free from the Fuel Pump Defect and the unreasonable safety risks it poses.

402. The Fuel Pump Defect causes damage to property other than the product, as explained in more detail above.

403. As a direct and proximate result of Defendants' actions as described herein, Plaintiff and the other members of the Class have been damaged in an amount to be determined at trial.

COUNT V

NEGLIGENT RECALL/UNDERTAKING (As to Subaru)

404. Plaintiffs restate and reallege, and incorporate herein by reference, the preceding paragraphs as if fully set forth herein and further allege as follows.

405. Plaintiffs assert this Count on behalf of themselves and the Nationwide Class or, in the alternative, on behalf of the state Subclasses.

406. Prior to the events made the basis of this action, Subaru designed, engineered, manufactured, marketed, and placed the Affected Vehicles in the stream of commerce.

407. On April 16, 2020 Subaru initiated a voluntary recall of the Recalled Vehicles. Subaru's recall was voluntary and not initiated by NHTSA.

408. Subaru owed a duty to use reasonable care to Plaintiffs and Class Members based on its undertaking of the Recall.

409. As described above, Subaru breached its duty by conducting the Recall negligently and/or wantonly by, among other things, failing to notify Plaintiffs and other Class members of the Fuel Pump Defect, failing to direct Class Members to stop driving their vehicles, and failing to offer Class Members a free loaner vehicle of comparable make, model, or value as their vehicles until Subaru is able to devise a remedy that is safe and dependable (if ever) and implement it in each Affected Vehicle. Subaru's failure to do so continues to expose Plaintiffs and other Class members to the risk of injury and death.

410. For the reasons set for the above, Subaru knew, or should have known through the exercise of ordinary care, the Recall was not being performed in a reasonable manner.

411. As a direct and proximate result, Plaintiffs and the other Class members have been and continue to be damaged in an amount to be determined at trial.

COUNT VI

VIOLATIONS OF THE NEW JERSEY CONSUMER FRAUD ACT (N.J. STAT. ANN. § 56:8-1, *ET SEQ.*) (As to all Defendants)

412. Plaintiffs Mutschler and Ferguson (“Plaintiffs,” for purposes of the next four counts) restate and reallege, and incorporate herein by reference, the preceding paragraphs as if fully set forth herein and further allege as follows:

413. Plaintiffs assert this Count on behalf of themselves and the Nationwide Class or, in the alternative, on behalf of the New Jersey Subclass.

414. Defendants and Plaintiffs are “persons” within the meaning of N.J. Stat. Ann. § 56:8-1(d).

415. Defendants engaged in “sales” of “merchandise” within the meaning of N.J. Stat. Ann. § 56:8-1(c), (d).

416. The New Jersey Consumer Fraud Act, N.J. Stat. Ann. § 56:8-1, et seq. (“N.J. CFA”), makes unlawful “[t]he act, use or employment by any person of any unconscionable commercial practice, deception, fraud, false pretense, false promise, misrepresentations, or the knowing concealment, suppression or omission, in connection with the sale or advertisement of any merchandise or real estate, or with the subsequent performance of such person as aforesaid, whether or not any person has in fact been misled, deceived or damaged thereby.” N.J. Stat. Ann. § 56:8-2. Defendants engaged in unconscionable commercial practice or deceptive acts or practices that violated the New Jersey CFA as described above and below, and did so with the intent that Plaintiffs rely upon their acts of concealment, suppression, and/or omission.

417. Defendants’ conduct proximately caused injuries to Plaintiffs and the other Class members.

418. Defendants intentionally, affirmatively, and knowingly misrepresented material facts regarding the Fuel Pump Defect and Affected Vehicles with intent to mislead Plaintiffs and the Class.

419. Defendants knew or should have known that its conduct violated the New Jersey CFA.

420. Plaintiffs and other Class members were injured and suffered ascertainable loss, injury in fact, and/or actual damage as a proximate result of Defendants' conduct in that Plaintiffs and the other Class members overpaid for their Affected Vehicles and did not receive the benefit of their bargain, and their Affected Vehicles have suffered a diminution in value. These injuries are the direct and natural consequence of Defendants' misrepresentations, fraud, deceptive practices, and omissions including, but not limited to, the use of a defective fuel pump in the manufacture of the Affected Vehicles and failure to implement a full and complete repair of that defect. As alleged in this Complaint, at all relevant times, the Recall Repair proposed by Subaru does not sufficiently address or fix the Fuel Pump Defect. Defendants are fully aware that the Recall Repair is an inadequate remedy and leaves Plaintiffs and Class members with an incomplete fix. The cost to Plaintiffs and Class members to replace the fuel pump module in the Affected Vehicles, which is the only complete and adequate repair of the defective fuel pump, is approximately \$500 to \$600. Defendants' violations present a continuing risk to Plaintiffs as well as to the general public. Defendants' unlawful acts and practices complained of herein affect the public interest.

421. Pursuant to N.J. Stat. Ann. § 56:8-19, Plaintiffs and the other Class members seek an order enjoining Defendants' unlawful conduct, actual damages, treble damages, attorneys' fees, costs, and any other just and proper relief available under the New Jersey CPA.

COUNT VII

BREACH OF IMPLIED WARRANTY OF MERCHANTABILITY (N.J. STAT. ANN. § 12A:2-314) (As to Subaru)

422. Plaintiffs restate and reallege, and incorporate herein by reference, the preceding paragraphs as if fully set forth herein and further allege as follows:

423. Plaintiffs assert this Count on behalf of themselves and the Nationwide Class or, in the alternative, on behalf of the New Jersey Subclass.

424. Subaru is a merchant with respect to motor vehicles within the meaning of N.J. Stat. Ann. § 12A:2-314.

425. Under N.J. Stat. Ann. § 12A:2-314, a warranty that the Affected Vehicles were in merchantable condition was implied by law in the transactions when Plaintiffs purchased or leased an Affected Vehicle from Defendants.

426. The Affected Vehicles, when sold and at all times thereafter, were not merchantable and are not fit for the ordinary purpose for which cars are used.

427. Subaru marketed the Affected Vehicles as safe, reliable, and high quality automobiles that would function as reasonably expected by consumers and in accordance with industry standards. Such representations formed the basis of the bargain in Plaintiffs' and the state Subclass members' decisions to purchase the Affected Vehicles.

428. Plaintiffs and other New Jersey Subclass members purchased the Affected Vehicles from Defendants, or through Subaru's authorized agents for retail sales. At all relevant times, Subaru was the manufacturer, distributor, warrantor, and/or seller of the Affected Vehicles.

429. Subaru knew or had reason to know of the specific use for which the Affected Vehicles were purchased.

430. Because of the Fuel Pump Defect, the Affected Vehicles were not in merchantable condition when sold and are not fit for the ordinary purpose of providing safe and reliable transportation.

431. Subaru knew about the defect in the Affected Vehicles, allowing Defendants to cure their breach of warranty if they chose.

432. Subaru's attempt to disclaim or limit the implied warranty of merchantability vis-à-vis consumers is unconscionable and unenforceable here. Specifically, Defendants' warranty limitations are unenforceable because they knowingly sold a defective product without informing consumers about the defect. The time limits contained in Defendants' warranty periods were also unconscionable and inadequate to protect Plaintiffs and other New Jersey Subclass members. Among other things, Plaintiffs and other New Jersey Subclass members had no meaningful choice in determining these time limitations, the terms of which unreasonably favored Subaru. A gross disparity in bargaining power existed between Subaru and New Jersey Subclass members, and Subaru knew of the defect at the time of sale.

433. Plaintiffs and New Jersey Subclass members have complied with all obligations under the warranty, or otherwise have been excused from performance of said obligations as a result of Subaru's conduct described herein. Affording Subaru a reasonable opportunity to cure the breach of written warranties therefore would be unnecessary and futile.

434. Subaru was provided notice of these issues by numerous complaints filed against it, internal investigations, postings on websites, and other sources.

435. Accordingly, Subaru is liable to Plaintiffs and New Jersey Subclass members for damages in an amount to be proven at trial.

COUNT VIII

**BREACH OF COVENANT OF GOOD FAITH AND FAIR DEALING
(BASED ON NEW JERSEY STATE LAW)
(As to Subaru)**

436. Plaintiffs incorporate by reference all preceding allegations as though fully set forth herein.

437. Plaintiffs assert this Count on behalf of themselves and the Nationwide Class or, in the alternative, on behalf of the New Jersey Subclass.

438. Plaintiffs and other Class members entered into contracts with Subaru in connection with the sale of the Affected Vehicles.

439. Plaintiffs and other Class members gave fair and reasonable consideration and performed all their material obligations under the contracts.

440. Implied in all contracts is a covenant of good faith and fair dealing, imposing a duty on the parties to act in good faith and deal fairly with one another.

441. Plaintiffs and other Class members had a reasonable expectation that, when they purchased their Affected Vehicles from Subaru, the Affected Vehicles would be free of defects, especially defects that affected the safety and operability of the Affected Vehicles.

442. Subaru used its discretion to place inferior low-pressure fuel pumps into the Affected Vehicles without informing Plaintiffs and New Jersey Subclass members that the inferior technology would create a safety defect in the Affected Vehicles.

443. Plaintiffs and New Jersey Subclass members had no reason to know Subaru had placed inferior low-pressure fuel pumps into the Affected Vehicles.

444. By creating and promoting an automobile with a latent safety defect, Subaru breached the covenant of good faith and fair dealing and breached its contractual duty to Plaintiffs and New Jersey Subclass members.

445. As a direct and proximate result of Subaru's breach, Plaintiffs and New Jersey Subclass members suffered damages, including being induced to purchase the defective Affected Vehicles.

COUNT IX

**UNJUST ENRICHMENT
(COMMON LAW)
(As to Subaru)**

446. Plaintiffs incorporate by reference all preceding allegations as though fully set forth herein.

447. Plaintiffs assert this Count on behalf of themselves and the Nationwide Class or, in the alternative, on behalf of the New Jersey Subclass.

448. Subaru received and retained a benefit from the Plaintiffs and other Class members, and inequity has resulted.

449. Subaru benefitted from selling and leasing the Affected Vehicles for more than they were worth as a result of Subaru's actions, at a profit, and Plaintiffs and Affected Members have overpaid for the Affected Vehicles and been forced to pay other costs.

450. Thus, all Plaintiffs and Class members conferred a benefit on Subaru.

451. It is inequitable for Subaru to retain these benefits.

452. Plaintiffs and Class members were not aware of the true facts about the Affected Vehicles prior to purchase or lease, and did not benefit from Subaru's conduct.

453. Subaru knowingly accepted the benefits of its unjust conduct. And, as a result of Subaru's conduct, the amount of its unjust enrichment should be determined in an amount according to proof.

B. Claims Brought on Behalf of the Alabama Subclass

COUNT X

**VIOLATIONS OF ALABAMA’S DECEPTIVE TRADE PRACTICES ACT
(ALA. CODE § 8-19-1 *ET SEQ.*)
(As to all Defendants)**

454. Plaintiffs Griffin, Oakley, and Whitley (for the purposes of the next two counts, “Plaintiffs”) incorporates by reference all paragraphs as though fully set forth herein.

455. The Alabama Deceptive Trade Practices Act, Ala. Code. § 8-19-5, prohibits “[e]ngaging in . . . unconscionable, false, or deceptive act[s] or practice[s] in business, commerce, or trade.”

456. In the course of their business, Defendants concealed and suppressed material facts concerning the Fuel Pump Defect. Defendants falsely represented the quality of the Affected Vehicles and omitted material facts regarding the fuel pump, as well as the durability and overall value of the Affected Vehicles, for the purpose of inducing Plaintiffs and other Alabama Subclass members to purchase the Affected Vehicles, and to increase Defendants’ revenue and profits.

457. The facts concealed and omitted by Defendants were material in that a reasonable consumer would have considered them to be important in deciding whether to purchase or lease the Affected Vehicles or pay a lower price. Had Plaintiffs and other Alabama Subclass members known of the Fuel Pump Defect, she would not have purchased or leased those vehicles, or would have paid substantially less for the vehicles than she did.

458. Plaintiff and the other Class members were injured and suffered ascertainable loss, injury in fact, and/or actual damages as a proximate result of Defendants’ conduct in that Plaintiff and the other Class members overpaid for their Affected Vehicles and did not get the benefit of her bargain, and her Affected Vehicles have suffered a diminution in value. These injuries are the direct and natural consequence of Subaru’s misrepresentations, fraud, deceptive practices, and

omissions. Defendants' violations present a continuing risk to Plaintiffs as well as to the general public. Defendants' unlawful acts and practices complained of herein affect the public interest.

459. Defendants are liable to Plaintiffs and Alabama Class members for treble her actual damages, punitive damages given that Defendants' conduct was malicious, wanton, willful, oppressive, or exhibited a reckless indifference to the rights of others, and fees and costs.

COUNT XI

BREACH OF IMPLIED WARRANTY OF MERCHANTABILITY (ALA. CODE §§ 7-2-314 AND 7-2A-314) (As to Subaru)

460. Plaintiffs incorporate by reference all paragraphs as though fully set forth herein.

461. Plaintiffs bring this Count on behalf of the Alabama Subclass members.

462. Subaru is a merchant with respect to motor vehicles under Ala. Code §§ 7-2-314 and 7-2A-314.

463. Under Ala. Code §§ 7-2-314 and 7-2A-314, a warranty that the Affected Vehicles were in merchantable condition was implied by law in the transactions when purchased or leased their Affected Vehicles from Subaru.

464. The Affected Vehicles, when sold and at all times thereafter, were not merchantable and are not fit for the ordinary purpose for which cars are used.

465. Subaru marketed the Affected Vehicles as safe, reliable, and high quality automobiles that would function as reasonably expected by consumers and in accordance with industry standards. Such representations formed the basis of the bargain in Plaintiffs' and Alabama Subclass members' decisions to purchase the Affected Vehicles.

466. Plaintiffs and other Alabama Subclass members purchased the Affected Vehicles from Subaru, or through Subaru's authorized agents for retail sales. At all relevant times, Subaru was the manufacturer, distributor, warrantor, and/or seller of the Affected Vehicles.

467. Subaru knew or had reason to know of the specific use for which the Affected Vehicles were purchased.

468. Because of the Fuel Pump Defect, the Affected Vehicles were not in merchantable condition when sold and are not fit for the ordinary purpose of providing safe and reliable transportation.

469. Subaru knew about the defect in the Affected Vehicles, allowing Subaru to cure their breach of warranty if it chose to do so.

470. Subaru's attempt to disclaim or limit the implied warranty of merchantability vis-à-vis consumers is unconscionable and unenforceable here. Specifically, Subaru's warranty limitations are unenforceable because they knowingly sold a defective product without informing consumers about the defect. The time limits contained in Subaru's warranty periods were also unconscionable and inadequate to protect Plaintiffs and other Alabama Subclass members. Among other things, Plaintiffs and other Alabama Subclass members had no meaningful choice in determining these time limitations, the terms of which unreasonably favored Subaru. A gross disparity in bargaining power existed between Subaru and Pennsylvania Subclass members, and Subaru knew of the defect at the time of sale.

471. Plaintiffs and Alabama Subclass members have complied with all obligations under the warranty, or otherwise have been excused from performance of said obligations as a result of Subaru's conduct described herein. Affording Subaru a reasonable opportunity to cure the breach of written warranties therefore would be unnecessary and futile.

472. Subaru was provided notice of these issues by numerous complaints filed against it, internal investigations, postings on websites, and other sources.

473. As a direct and proximate result of Subaru's breach of the implied warranty of merchantability, Plaintiffs and the Class have been damaged in an amount to be proven at trial.

C. Claims Brought on Behalf of the Arkansas Subclass

COUNT XII

**VIOLATIONS OF THE DECEPTIVE TRADE PRACTICE ACT
(ARK. CODE ANN. § 4-88-101 *ET SEQ.*)
(As to all Defendants)**

474. Plaintiff Mein De Vera (for purposes of the next two counts, "Plaintiff") incorporates by reference all paragraphs though fully set forth herein.

475. Plaintiff bring this Count on behalf of the Arkansas Subclass members.

476. Defendants, Plaintiff, and other Class Members are "persons" within the meaning of the Arkansas Deceptive Trade Practices Act ("Arkansas DTPA"), Ark. Code Ann. § 4-88-102(5).

477. The Affected Vehicles are "goods" within the meaning of Ark. Code. Ann. § 4-88-102(4).

478. The Arkansas DTPA prohibits "[d]eceptive and unconscionable trade practices," which include, but are not limited to, a list of enumerated items, including "[e]ngaging in any other unconscionable, false, or deceptive act or practice in business, commerce, or trade." Ark. Code Ann. § 4-88-107(a)(10). The Arkansas DTPA also prohibits the following when utilized in connection with the sale or advertisement of any goods: "(1) The act, use, or employment by any person of any deception, fraud, or false pretense; or (2) The concealment, suppression, or omission of any material fact with intent that others rely upon the concealment, suppression, or omission." Ark. Code Ann. § 4-88-108.

479. The facts concealed and omitted by Defendants were material in that a reasonable consumer would have considered them to be important in deciding whether to purchase or lease the Affected Vehicles or pay a lower price. Had Plaintiff and other Arkansas Subclass members known of the Fuel Pump Defect, they would not have purchased or leased those vehicles, or would have paid substantially less for the vehicles than they did.

480. Defendants' conduct proximately caused injuries to Plaintiff and the other Arkansas Subclass members.

481. Plaintiff and the other Arkansas Subclass members were injured and suffered ascertainable loss, injury in fact, and/or actual damage as a proximate result of Subaru's conduct in that Plaintiff and the other Arkansas Subclass members overpaid for their Affected Vehicles and did not receive the benefit of their bargain, and their Affected Vehicles have suffered a diminution in value. These injuries are the direct and natural consequence of Subaru's misrepresentations, fraud, deceptive practices, and omissions.

482. Defendants' violations present a continuing risk to Plaintiff as well as to the general public. Defendants' unlawful acts and practices complained of herein affect the public interest.

483. Plaintiff and the Class seek monetary relief against Defendants in an amount to be determined at trial. Plaintiff and the Class also seek punitive damages because Subaru engaged in aggravated and outrageous conduct with an evil mind. Indeed, Defendants carried out despicable conduct with willful and conscious disregard of the rights of others. Defendants' unlawful conduct constitutes malice, oppression, and fraud warranting punitive damages.

484. Plaintiff also seek attorneys' fees and any other just and proper relief available.

COUNT XIII

BREACH OF THE IMPLIED WARRANTY OF MERCHANTABILITY
(ARK. CODE ANN. §§ 4-2-314, 4-2A-212)
(As to Subaru)

485. Plaintiff incorporates by reference all paragraphs as though fully set forth herein.

486. Plaintiff bring this Count on behalf of the Arkansas Class members.

487. Subaru is a merchant with respect to motor vehicles within the meaning of the Ark. Code Ann. §§ 4-2-314.

488. Under Ark. Code Ann. § 4-2-314, a warranty that the Affected Vehicles were in merchantable condition was implied by law in the transactions when Plaintiff and the Class purchased or leased their Affected Vehicles from Subaru.

489. The Affected Vehicles, when sold and at all times thereafter, were not merchantable and are not fit for the ordinary purpose for which cars are used.

490. Subaru marketed the Affected Vehicles as safe, reliable, and high quality automobiles that would function as reasonably expected by consumers and in accordance with industry standards. Such representations formed the basis of the bargain in Plaintiff's and Arkansas Subclass members' decisions to purchase the Affected Vehicles.

491. Plaintiff and other Arkansas Subclass members purchased the Affected Vehicles from Subaru, or through Subaru's authorized agents for retail sales. At all relevant times, Subaru was the manufacturer, distributor, warrantor, and/or seller of the Affected Vehicles.

492. Subaru knew or had reason to know of the specific use for which the Affected Vehicles were purchased.

493. Because of the Fuel Pump Defect, the Affected Vehicles were not in merchantable condition when sold and are not fit for the ordinary purpose of providing safe and reliable transportation.

494. Subaru knew about the defect in the Affected Vehicles, allowing Subaru to cure their breach of warranty if it chose to do so.

495. Subaru's attempt to disclaim or limit the implied warranty of merchantability vis-à-vis consumers is unconscionable and unenforceable here. Specifically, Subaru's warranty limitations are unenforceable because they knowingly sold a defective product without informing consumers about the defect. The time limits contained in Subaru's warranty periods were also unconscionable and inadequate to protect Plaintiff and other Arkansas Subclass members. Among other things, Plaintiff and other Arkansas Subclass members had no meaningful choice in determining these time limitations, the terms of which unreasonably favored Subaru. A gross disparity in bargaining power existed between Subaru and Arkansas Subclass members, and Subaru knew of the defect at the time of sale.

496. Plaintiff and Arkansas Subclass members have complied with all obligations under the warranty, or otherwise have been excused from performance of said obligations as a result of Subaru's conduct described herein. Affording Subaru a reasonable opportunity to cure the breach of written warranties therefore would be unnecessary and futile.

497. Subaru was provided notice of these issues by numerous complaints filed against it, internal investigations, postings on websites, and other sources.

498. As a direct and proximate result of Subaru's breach of the implied warranty of merchantability, Plaintiff and the Class have been damaged in an amount to be proven at trial.

D. Claims Brought on Behalf of the California Subclass

COUNT XIV

**VIOLATIONS OF THE CALIFORNIA UNFAIR COMPETITION LAW
(CAL. BUS. & PROF. CODE § 17200, ET SEQ.)
(As to all Defendants)**

499. Plaintiffs Adnan, Woo, and Bancod-Wile (for purposes of the next five counts, “Plaintiffs”) restates and realleges, and incorporates herein by reference, the preceding paragraphs as if fully set forth herein and further alleges as follows.

500. Plaintiffs bring this claim on behalf of themselves and the California Subclass.

501. California’s Unfair Competition Law (“UCL”), Business and Professions Code § 17200, prohibits any “unlawful, unfair, or fraudulent business act or practices.”

502. In the course of their business, Defendants concealed and suppressed material facts concerning the Fuel Pump Defect. Subaru falsely represented the quality of the Affected Vehicles and omitted material facts regarding the fuel pump, as well as the durability and overall value of the Affected Vehicles, for the purpose of inducing Plaintiffs and other California Subclass members to purchase the Affected Vehicles, and to increase Defendants revenue and profits.

503. The facts concealed and omitted by Subaru were material in that a reasonable consumer would have considered them to be important in deciding whether to purchase or lease the Affected Vehicles or pay a lower price. Had Plaintiffs and other California Subclass members known of the Fuel Pump Defect, they would not have purchased or leased those vehicles, or would have paid substantially less for the vehicles than they did.

504. Defendants’ violations present a continuing risk to Plaintiffs as well as to the general public. Defendants’ unlawful acts and practices complained of herein affect the public interest.

505. Pursuant to CAL. BUS. & PROF. CODE § 17200, Plaintiffs and the California Subclass seek any such orders or judgments as may be necessary to restore to Plaintiffs and California Subclass members any money acquired by unfair competition, including restitution and/or restitutionary disgorgement, as provided in CAL. BUS.& PROF. CODE §§ 17203 and 3345, and any other just and proper relief available under the UCL.

COUNT XV

VIOLATIONS OF THE CALIFORNIA CONSUMER LEGAL REMEDIES ACT (CAL. CIV. CODE § 1750, ET SEQ.) (As to Subaru)

506. Plaintiffs restate and reallege, and incorporates herein by reference, the preceding paragraphs as if fully set forth herein and further alleges as follows.

507. Plaintiffs bring this claim on behalf of themselves and the California Subclass.

508. California’s Consumers Legal Remedies Act (“CLRA”), CAL. CIV. CODE § 1750, et seq., proscribes “unfair methods of competition and unfair or deceptive acts or practices undertaken by any person in a transaction intended to result or which results in the sale or lease of goods or services to any consumer.”

509. The Affected Vehicles are “goods” as defined in CAL. CIV. CODE § 1761(a).

510. Plaintiffs and the California Subclass members are “consumers” as defined in CAL. CIV. CODE § 1761(d), and Plaintiffs, the California Subclass members, and Subaru are “persons” as defined in CAL. CIV. CODE § 1761(c).

511. As alleged above, Subaru made representations concerning the reliability and safety of the Affected Vehicles that were misleading.

512. In purchasing or leasing the Affected Vehicles, Plaintiffs, and California Subclass members were deceived by Subaru’s failure to disclose the Fuel Pump Defect.

513. Subaru's conduct, as described herein, was and is in violation of the CLRA and violates at least the following enumerated CLRA provisions:

- a. CAL. CIV. CODE § 1770(a)(2): Misrepresenting the approval or certification of goods;
- b. CAL. CIV. CODE § 1770(a)(3): Misrepresenting the certification by another;
- c. CAL. CIV. CODE § 1770(a)(5): Representing that goods have sponsorship, approval, characteristics, uses, benefits, or quantities which they do not have;
- d. CAL. CIV. CODE § 1770(a)(7): Representing that goods are of a particular standard, quality, or grade, if they are of another;
- e. CAL. CIV. CODE § 1770(a)(9): Advertising goods with intent not to sell them as advertised; and
- f. CAL. CIV. CODE § 1770(a)(16): Representing that goods have been supplied in accordance with a previous representation when they have not.

514. Subaru intentionally and knowingly failed to disclose and misrepresented material facts regarding the Affected Vehicles with an intent to mislead Plaintiffs and California Subclass members.

515. In purchasing or leasing the Affected Vehicles, Plaintiffs and the California Subclass members were deceived by Subaru's failure to disclose the defect, as described above.

516. Plaintiffs and the California Subclass members reasonably relied upon Subaru's material omissions and false misrepresentations. They had no way of knowing that Subaru's representations were false and gravely misleading. Plaintiffs and the California Subclass members did not, and could not, unravel Subaru's deception on their own.

517. Subaru knew or should have known that its conduct violated the CLRA.

518. Subaru owed Plaintiffs and the California Subclass members a duty to disclose the truth about its emissions systems manipulation because Subaru:

519. a. possessed exclusive knowledge about the fuel systems in the Affected Vehicles, including the defect; and

520. b. intentionally concealed the foregoing from Plaintiffs and the California Subclass members.

521. Subaru had a duty to disclose that the Affected Vehicles were defective, because, having volunteered to provide information to Plaintiffs and the California Subclass members, Subaru had the duty to disclose not just the partial truth, but the entire truth.

522. Subaru also had a duty to disclose that the Affected Vehicles were defective because the defect creates a safety issue.

523. Further, Plaintiffs and the California Subclass members relied on Subaru's material omissions and representations that the Affected Vehicles they were purchasing were free from defects.

524. Plaintiffs and the California Subclass members were unaware of the omitted material facts referenced herein, and they would not have acted as they did if they had known of the concealed and/or suppressed facts, in that they would not have purchased the Affected Vehicles, or would have paid less for them. Plaintiffs' and the California Subclass members' actions were justified. Subaru was in exclusive control of the material facts, and such facts were not generally known to the public, Plaintiffs, or the California Subclass members.

525. Subaru's conduct proximately caused injuries to Plaintiffs and the California Subclass members.

526. Plaintiffs and the California Subclass members were injured and suffered ascertainable loss, injury-in-fact, and/or actual damage as a proximate result of Subaru's conduct in that Plaintiffs and the other Class members overpaid for their Affected Vehicles and did not receive the benefit of their bargain, and their Affected Vehicles have suffered a diminution in value. These injuries are the direct and natural consequence of Subaru's misrepresentations and omissions.

527. Subaru's violations present a continuing risk to Plaintiffs as well as to the general public. Subaru's unlawful acts and practices complained of herein affect the public interest.

528. Subaru knew, should have known, or was reckless in not knowing of the defect in the fuel system and that the Affected Vehicles were not suitable for their intended use.

529. The facts concealed and omitted by Subaru from Plaintiffs and the California Subclass members are material in that a reasonable consumer would have considered them to be important in deciding whether to purchase or lease the Affected Vehicles or pay a lower price. Had Plaintiffs and the California Subclass members known about the defective nature of the Affected Vehicles, they would not have purchased or leased the Affected Vehicles or would not have paid the prices they paid.

530. Plaintiffs' and the California Subclass members' injuries were proximately caused by Subaru's unlawful and deceptive business practices.

531. Plaintiffs and the California Subclass members are entitled to recover actual and punitive damages under the CLRA pursuant to CAL. CIV. CODE § 1780(a), and an additional award of up to \$5,000 to each Plaintiffs and California Subclass member who is a "senior citizen."

COUNT XVI

**VIOLATIONS OF THE CALIFORNIA FALSE ADVERTISING LAW
(CAL. BUS. & PROF. CODE § 17500, ET SEQ.)
(As to Subaru)**

532. Plaintiffs restate and reallege, and incorporates herein by reference, the preceding paragraphs as if fully set forth herein and further alleges as follows.

533. Plaintiffs bring this claim on behalf of themselves and the California Subclass.

534. CALIFORNIA BUS.& PROF. CODE § 17500 states: “It is unlawful for any ... corporation ... with intent directly or indirectly to dispose of real or personal property ... to induce the public to enter into any obligation relating thereto, to make or disseminate or cause to be made or disseminated ... from this state before the public in any state, in any newspaper or other publication, or any advertising device, ... or in any other manner or means whatever, including over the Internet, any statement ... which is untrue or misleading, and which is known, or which by the exercise of reasonable care should be known, to be untrue or misleading.”

535. Subaru caused to be made or disseminated through California and the United States, through advertising, marketing and other publications, statements that were untrue or misleading, and which were known, or which by the exercise of reasonable care should have been known to Subaru, to be untrue and misleading to consumers, including Plaintiffs and the California Subclass members.

536. Subaru has violated CAL. BUS. & PROF. CODE § 17500 because the misrepresentations and omissions regarding the reliability and safety of the Affected Vehicles as set forth in this Complaint were material and likely to deceive a reasonable consumer.

537. Plaintiffs and the California Subclass members have suffered an injury in fact, including the loss of money or property, as a result of Subaru’s unfair, unlawful, and/or deceptive

practices. In purchasing or leasing their Affected Vehicles, Plaintiffs and the California Subclass members relied on the misrepresentations and/or omissions of Subaru with respect to the reliability and safety of the Affected Vehicles.

538. All of the wrongful conduct alleged herein occurred, and continues to occur, in the conduct of Subaru's business. Subaru's wrongful conduct is part of a pattern or generalized course of conduct that is still perpetuated and repeated, both in the State of California and nationwide.

539. Plaintiffs, individually and on behalf of the California Subclass, request that this Court enter such orders or judgments as may be necessary to restore to Plaintiffs and the California Subclass members any money Subaru acquired by unfair competition, including restitution and/or restitutionary disgorgement and for such other relief as may be appropriate.

COUNT XVII

BREACH OF IMPLIED WARRANTIES (CAL. COM. CODE §§ 2314, 10103, AND 10212) (As to Subaru)

540. Plaintiffs restate and reallege, and incorporates herein by reference, the preceding paragraphs as if fully set forth herein and further alleges as follows.

541. Plaintiffs bring this claim on behalf of themselves and the California Subclass.

542. Subaru is and was at all relevant times a "merchant" with respect to the Affected Vehicles under CAL. COM. CODE §§ 2104(1) and 10103(c), and "seller" of the Affected Vehicles under § 2103(1)(d).

543. With respect to leases, Subaru is and was at all relevant times "lessors" of motor vehicles under CAL. COM. CODE § 10103(a)(16).

544. The Affected Vehicles are and were at all relevant times "goods" within the meaning of CAL. COM. CODE §§ 2105(1) and 10103(a)(8).

545. A warranty that the Affected Vehicles were in merchantable condition and fit for their ordinary purpose is implied by law pursuant to CAL. COM. CODE §§ 2314 and 10212.

546. In addition, a warranty that the Affected Vehicles were fit for their particular purpose is implied by law pursuant to CAL. COM. CODE § 2315. Subaru knew at the time of sale that Plaintiffs and the California Subclass intended to use the Affected Vehicles for a purpose requiring a particular standard of performance, reliability and safety, and that Plaintiffs and the California Subclass were relying on Subaru's skill and judgment to furnish suitable products for this particular purpose.

547. The Affected Vehicles, when sold and at all times thereafter, were not merchantable and are not fit for the ordinary purpose for which cars are used.

548. Subaru marketed the Affected Vehicles as safe, reliable, and high quality automobiles that would function as reasonably expected by consumers and in accordance with industry standards. Such representations formed the basis of the bargain in Plaintiffs' and California Subclass members' decisions to purchase the Affected Vehicles.

549. Plaintiffs and other California Subclass members purchased the Affected Vehicles from Subaru, or through Subaru's authorized agents for retail sales. At all relevant times, Subaru was the manufacturer, distributor, warrantor, and/or seller of the Affected Vehicles.

550. Subaru knew or had reason to know of the specific use for which the Affected Vehicles were purchased.

551. Because of the Fuel Pump Defect, the Affected Vehicles were not in merchantable condition when sold and are not fit for the ordinary purpose of providing safe and reliable transportation.

552. Subaru knew about the defect in the Affected Vehicles, allowing Subaru to cure their breach of warranty if it chose to do so.

553. Subaru's attempt to disclaim or limit the implied warranty of merchantability vis-à-vis consumers is unconscionable and unenforceable here. Specifically, Subaru's warranty limitations are unenforceable because they knowingly sold a defective product without informing consumers about the defect. The time limits contained in Subaru's warranty periods were also unconscionable and inadequate to protect Plaintiffs and other California Subclass members. Among other things, Plaintiffs and other California Subclass members had no meaningful choice in determining these time limitations, the terms of which unreasonably favored Subaru. A gross disparity in bargaining power existed between Subaru and California Subclass members, and Subaru knew of the defect at the time of sale.

554. Plaintiffs and California Subclass members have complied with all obligations under the warranty, or otherwise have been excused from performance of said obligations as a result of Subaru's conduct described herein. Affording Subaru a reasonable opportunity to cure the breach of written warranties therefore would be unnecessary and futile.

555. Subaru was provided notice of these issues by numerous complaints filed against it, internal investigations, postings on websites, and other sources.

556. Accordingly, Subaru is liable to Plaintiffs and California Subclass members for damages in an amount to be proven at trial.

COUNT XVIII

**VIOLATIONS OF SONG-BEVERLY CONSUMER WARRANTY ACT
FOR BREACH OF IMPLIED WARRANTIES
(CAL. CIV. CODE §§ 1791.1 AND 1792)
(As to Subaru)**

557. Plaintiffs reallege and incorporates by reference all preceding allegations as though fully set forth herein.

558. Plaintiffs bring this claim on behalf of himself and the California Subclass.

559. Plaintiffs and the California Subclass members who purchased or leased Affected Vehicles in California are “buyers” within the meaning of CAL. CIV. CODE § 1791.

560. The Affected Vehicles are “consumer goods” within the meaning of CAL. CIV. CODE § 1791(a).

561. Subaru is a “manufacturer” of the Affected Vehicles within the meaning of CAL. CIV. CODE § 1791(j).

562. Subaru impliedly warranted to Plaintiffs and California Subclass members that the Affected Vehicles were “merchantable” within the meaning of CAL. CIV. CODE §§ 1791.1(a) and 1792; however, the Affected Vehicles do not have the quality that a buyer would reasonably expect.

563. CAL. CIV. CODE § 1791.1(a) states: “Implied warranty of merchantability” or “implied warranty that goods are merchantable” means that the consumer goods meet each of the following:

- i. Pass without objection in the trade under the contract description.
- ii. Are fit for the ordinary purposes for which such goods are used.
- iii. Are adequately contained, packaged, and labeled.
- iv. Conform to the promises or affirmations of fact made on the container or label.

341. The Affected Vehicles, when sold and at all times thereafter, were not merchantable and are not fit for the ordinary purpose for which cars are used.

564. Subaru marketed the Affected Vehicles as safe, reliable, and high quality automobiles that would function as reasonably expected by consumers and in accordance with industry standards. Such representations formed the basis of the bargain in Plaintiffs' and California Subclass members' decisions to purchase the Affected Vehicles.

565. Plaintiffs and other California Subclass members purchased the Affected Vehicles from Subaru, or through Subaru's authorized agents for retail sales. At all relevant times, Subaru was the manufacturer, distributor, warrantor, and/or seller of the Affected Vehicles.

566. Subaru knew or had reason to know of the specific use for which the Affected Vehicles were purchased.

567. Because of the Fuel Pump Defect, the Affected Vehicles were not in merchantable condition when sold and are not fit for the ordinary purpose of providing safe and reliable transportation.

568. Subaru knew about the defect in the Affected Vehicles, allowing Subaru to cure their breach of warranty if it chose to do so.

569. Subaru's attempt to disclaim or limit the implied warranty of merchantability vis-à-vis consumers is unconscionable and unenforceable here. Specifically, Subaru's warranty limitations are unenforceable because they knowingly sold a defective product without informing consumers about the defect. The time limits contained in Subaru's warranty periods were also unconscionable and inadequate to protect Plaintiffs and other California Subclass members. Among other things, Plaintiffs and other California Subclass members had no meaningful choice in determining these time limitations, the terms of which unreasonably favored Subaru. A gross disparity in bargaining power existed between Subaru and California Subclass members, and Subaru knew of the defect at the time of sale.

570. Plaintiffs and California Subclass members have complied with all obligations under the warranty, or otherwise have been excused from performance of said obligations as a result of Subaru's conduct described herein. Affording Subaru a reasonable opportunity to cure the breach of written warranties therefore would be unnecessary and futile.

571. Subaru was provided notice of these issues by numerous complaints filed against it, internal investigations, postings on websites, and other sources.

572. Accordingly, Subaru is liable to Plaintiffs and California Subclass members for damages in an amount to be proven at trial..

573. Under CAL. CIV. CODE §§ 1791.1(d) and 1794, Plaintiffs and the California Subclass members are entitled to damages and other legal and equitable relief including, at their election, the purchase price of their Affected Vehicles, or the overpayment or diminution in value of their Affected Vehicles.

574. Under CAL. CIV. CODE § 1794, Plaintiffs and the California Subclass members are entitled to costs and attorneys' fees.

E. Claims Brought on Behalf of the Connecticut Subclass

COUNT XIX

**VIOLATION OF THE CONNECTICUT UNFAIR TRADE PRACTICES ACT
(CONN. GEN. STAT. § 42-110A *ET SEQ.*)
(As to all Defendants)**

575. Plaintiff Martin Torresquintero ("Plaintiff," for purposes of the next two counts) incorporates by reference all paragraphs as though full set forth herein.

576. Plaintiff brings this Count on behalf of the Connecticut Subclass members.

577. Plaintiff is a person under the Connecticut Unfair Trade Practices Act ("Connecticut UTPA"). Conn. Gen. Stat. § 42-110a(3).

578. The Connecticut UTPA prohibits all “unfair methods of competition and unfair or deceptive acts or practices in the conduct of trade or commerce” Conn. Gen. Stat § 42-110b(a).

579. Defendants engaged in unfair and deceptive practices through the course of their representations and omissions relating to Affected Vehicles and their conduct of their recall, As alleged above.

580. The facts concealed and omitted by Defendants were material in that a reasonable consumer would have considered them to be important in deciding whether to purchase or lease the Affected Vehicles or pay a lower price. Had Plaintiff and other Connecticut Subclass members known of the Fuel Pump Defect, they would not have purchased or leased those vehicles, or would have paid substantially less for the vehicles than they did.

581. Defendants’ conduct proximately caused injuries to Plaintiff and the other Rhode Island Subclass members.

582. Plaintiff and the other Connecticut Subclass members were injured and suffered ascertainable loss, injury in fact, and/or actual damage as a proximate result of Defendants’ conduct in that Plaintiff and the other Connecticut Subclass members overpaid for their Affected Vehicles and did not receive the benefit of their bargain, and their Affected Vehicles have suffered a diminution in value. These injuries are the direct and natural consequence of Subaru’s misrepresentations, fraud, deceptive practices, and omissions.

583. Defendants’ violations present a continuing risk to Plaintiff as well as to the general public. Defendants’ unlawful acts and practices complained of herein affect the public interest.

584. Plaintiff and the Class members are entitled to recover actual and punitive damages, declaratory and injunctive relieve, and attorneys’ fees and costs. Conn. Gen. Stat. § 42-110g.

COUNT XX

**BREACH OF IMPLIED WARRANTY OF MERCHANTABILITY
(CONN. GEN. STAT. § 42A-2-314)
(As to Subaru)**

585. Plaintiff incorporates by reference all paragraphs as though fully set forth herein.

586. Plaintiff brings this Count on behalf of the Connecticut Subclass members.

587. Subaru is a merchant with respect to motor vehicles under Conn. Gen. Stat. § 42a-2-314.

588. Under Conn. Gen. Stat. § 42a-2-314, a warranty that the Affected Vehicles were in merchantable condition was implied by law in the transactions when Plaintiff and Class members purchased or leased their Affected Vehicles from Subaru.

589. The Affected Vehicles, when sold and at all times thereafter, were not merchantable and are not fit for the ordinary purpose for which cars are used.

590. Subaru marketed the Affected Vehicles as safe, reliable, and high quality automobiles that would function as reasonably expected by consumers and in accordance with industry standards. Such representations formed the basis of the bargain in Plaintiff's and Connecticut Subclass members' decisions to purchase the Affected Vehicles.

591. Plaintiff and other Connecticut Subclass members purchased the Affected Vehicles from Subaru, or through Subaru's authorized agents for retail sales. At all relevant times, Subaru was the manufacturer, distributor, warrantor, and/or seller of the Affected Vehicles.

592. Subaru knew or had reason to know of the specific use for which the Affected Vehicles were purchased.

593. Because of the Fuel Pump Defect, the Affected Vehicles were not in merchantable condition when sold and are not fit for the ordinary purpose of providing safe and reliable transportation.

594. Subaru knew about the defect in the Affected Vehicles, allowing Subaru to cure their breach of warranty if it chose to do so.

595. Subaru's attempt to disclaim or limit the implied warranty of merchantability vis-à-vis consumers is unconscionable and unenforceable here. Specifically, Subaru's warranty limitations are unenforceable because they knowingly sold a defective product without informing consumers about the defect. The time limits contained in Subaru's warranty periods were also unconscionable and inadequate to protect Plaintiff and other Connecticut Subclass members. Among other things, Plaintiff and other Connecticut Subclass members had no meaningful choice in determining these time limitations, the terms of which unreasonably favored Subaru. A gross disparity in bargaining power existed between Subaru and Connecticut Subclass members, and Subaru knew of the defect at the time of sale.

596. Plaintiff and Connecticut Subclass members have complied with all obligations under the warranty, or otherwise have been excused from performance of said obligations as a result of Subaru's conduct described herein. Affording Subaru a reasonable opportunity to cure the breach of written warranties therefore would be unnecessary and futile.

597. Subaru was provided notice of these issues by numerous complaints filed against it, internal investigations, postings on websites, and other sources.

598. As a direct and proximate result of Subaru's breach of the implied warranty of merchantability, Plaintiff and the Class have been damaged in an amount to be proven at trial

F. Claims Brought on Behalf of the Florida Subclass

COUNT XXI

**VIOLATIONS OF THE FLORIDA DECEPTIVE AND
UNFAIR TRADE PRACTICES ACT ("FDUTPA")
(FLA. STAT. ANN. § 501.201, *ET SEQ.*)
(As to all Defendants)**

599. Plaintiff Gilles Cohen (for purposes of the next three counts, “Plaintiff”) restates and realleges, and incorporates herein by reference, the preceding paragraphs as if fully set forth herein and further alleges as follows:

600. Plaintiff brings this Count on behalf of himself and all similarly situated residents of the state of Florida for violations of Florida’s Deceptive and Unfair Trade Practices Act.

601. Plaintiff and other Florida Subclass members who purchased their vehicles new are “consumers” within the meaning of the Florida Deceptive and Unfair Trade Practices Act, Fla. Stat. Ann. § 501.203(7).

602. Defendants engaged in “trade or commerce” within the meaning of Fla. Stat. Ann. § 501.203(8).

603. The FDUTPA prohibits “[u]nfair methods of competition, unconscionable acts or practices, and unfair or deceptive acts or practices in the conduct of any trade or commerce.” Fla. Stat. Ann. § 501.204(1). Defendants participated in unfair and deceptive trade practices that violated the FDUTPA as described herein. In the course of their business, Defendants concealed and suppressed material facts concerning the Fuel Pump Defect. Defendants falsely represented the quality of the Affected Vehicles and omitted material facts regarding the fuel pump, as well as the durability and overall value of the fuel pumps and the Affected Vehicles, for the purpose of inducing Plaintiff and other Florida Subclass members to purchase the Affected Vehicles, and to increase Defendants’ revenue and profits.

604. The facts concealed and omitted by Defendants were material in that a reasonable consumer would have considered them to be important in deciding whether to purchase or lease the Affected Vehicles or pay a lower price. Had Plaintiff and other Florida Subclass members

known of the Fuel Pump Defect, they would not have purchased or leased those vehicles, or would have paid substantially less for the vehicles than they did.

605. Defendants' conduct proximately caused injuries to Plaintiff and the other Florida Subclass members.

606. Plaintiff and the other Florida Subclass members were injured and suffered ascertainable loss, injury in fact, and/or actual damage as a proximate result of Defendants' conduct in that Plaintiff and the other Florida Subclass members overpaid for their Affected Vehicles and did not receive the benefit of their bargain, and their Affected Vehicles have suffered a diminution in value. These injuries are the direct and natural consequence of Defendants' misrepresentations, fraud, deceptive practices, and omissions.

607. Defendants' violations present a continuing risk to Plaintiff as well as to the general public. Defendants' unlawful acts and practices complained of herein affect the public interest.

608. Accordingly, Defendants are liable to Plaintiff and the other Florida Subclass members for damages in an amount to be proven at trial.

COUNT XXII

BREACH OF IMPLIED WARRANTY OF MERCHANTABILITY (FLA. STAT. ANN. §§ 672.314 AND 680.212) (As to Subaru)

609. Plaintiff restates and realleges, and incorporates herein by reference, the preceding paragraphs as if fully set forth herein and further alleges as follows:

610. Plaintiff brings this Count on behalf of himself and all other similarly situated residents of the state of Florida for violations of implied warranty of merchantability under Florida law.

611. Subaru was at all times a “merchant” with respect to motor vehicles under Fla. Stat. Ann. §§ 672.104(1) and 680.1031(3)(k), and a “seller” of motor vehicles under § 672.103(1)(d).

612. With respect to leases, Subaru is and was at all relevant times a “lessor” of motor vehicles under Fla. Stat. Ann. § 680.1031(1)(p).

613. The Affected Vehicles are and were at all relevant times “goods” within the meaning of Fla. Stat. Ann. §§ 672.105(1) and 680.1031(1)(h).

614. A warranty that the Affected Vehicles were in merchantable condition and fit for the ordinary purpose for which the vehicles are used is implied by law, pursuant to Fla. Stat. Ann. §§ 672.314 and 680.212.

615. The Affected Vehicles, when sold and at all times thereafter, were not merchantable and are not fit for the ordinary purpose for which cars are used.

616. Subaru marketed the Affected Vehicles as safe, reliable, and high quality automobiles that would function as reasonably expected by consumers and in accordance with industry standards. Such representations formed the basis of the bargain in Plaintiff’s and Florida Subclass members’ decisions to purchase the Affected Vehicles.

617. Plaintiff and other Florida Subclass members purchased the Affected Vehicles from Subaru, or through Subaru’s authorized agents for retail sales. At all relevant times, Subaru was the manufacturer, distributor, warrantor, and/or seller of the Affected Vehicles.

618. Subaru knew or had reason to know of the specific use for which the Affected Vehicles were purchased.

619. Because of the Fuel Pump Defect, the Affected Vehicles were not in merchantable condition when sold and are not fit for the ordinary purpose of providing safe and reliable transportation.

620. Subaru knew about the defect in the Affected Vehicles, allowing Subaru to cure their breach of warranty if it chose to do so.

621. Subaru's attempt to disclaim or limit the implied warranty of merchantability vis-à-vis consumers is unconscionable and unenforceable here. Specifically, Subaru's warranty limitations are unenforceable because they knowingly sold a defective product without informing consumers about the defect. The time limits contained in Subaru's warranty periods were also unconscionable and inadequate to protect Plaintiff and other Florida Subclass members. Among other things, Plaintiff and other Florida Subclass members had no meaningful choice in determining these time limitations, the terms of which unreasonably favored Subaru. A gross disparity in bargaining power existed between Subaru and Florida Subclass members, and Subaru knew of the defect at the time of sale.

622. Plaintiff and Florida Subclass members have complied with all obligations under the warranty, or otherwise have been excused from performance of said obligations as a result of Subaru's conduct described herein. Affording Subaru a reasonable opportunity to cure the breach of written warranties therefore would be unnecessary and futile.

623. Subaru was provided notice of these issues by numerous complaints filed against it, internal investigations, postings on websites, and other sources.

624. Accordingly, Subaru is liable to Plaintiff and Florida Subclass members for damages in an amount to be proven at trial.

COUNT XXXIII

**BREACH OF COVENANT OF GOOD FAITH AND FAIR DEALING
(BASED ON FLORIDA STATE LAW)
(As to Subaru)**

625. Plaintiff incorporates by reference all preceding allegations as though fully set forth herein.

626. Plaintiff brings this Count on behalf of himself and all similarly situated residents of the state of Florida.

627. Plaintiff and Florida Subclass members entered into contracts with Subaru in connection with the sale of the Affected Vehicles.

628. Plaintiff and Florida Subclass members gave fair and reasonable consideration and performed all their material obligations under the contracts.

629. Implied in all contracts is a covenant of good faith and fair dealing, imposing a duty on the parties to act in good faith and deal fairly with one another.

630. Plaintiff and Florida Subclass members had a reasonable expectation that when they purchased their Affected Vehicles from Subaru, the Affected Vehicles would be free of defects, especially defects that affected the safety and operability of the Affected Vehicles.

631. Subaru made the decision to place inferior low-pressure fuel pumps into the Affected Vehicles without informing Plaintiff and Florida Subclass members that the inferior technology would create a safety defect in the Affected Vehicles.

632. Plaintiff and Florida Subclass members had no reason to know Subaru had placed inferior low-pressure fuel pumps into the Affected Vehicles.

633. By creating and promoting an automobile with a latent safety defect, Subaru breached the covenant of good faith and fair dealing and breached its contractual duty to Plaintiff and Florida Subclass members.

634. As a direct and proximate result of Subaru's breach, Plaintiff and Florida Subclass members suffered damages, including being induced to purchase the defective Affected Vehicles.

G. Claims Brought on Behalf of the Hawaii Subclass

COUNT XXIV

**VIOLATIONS OF HAWAII'S UNFAIR DECEPTIVE ACTS
AND PRACTICES STATUTE
(H.R.S. § 480-1 *ET SEQ.*)
(As to all Defendants)**

635. Plaintiff Anderson (for the purposes of the next two counts, “Plaintiff”) incorporates by reference all paragraphs as though fully set forth herein.

636. Plaintiff brings this Count on behalf of the Hawaii Class members.

637. Plaintiff and other Class members are “consumers” for the purposes of the Hawaii’s Unfair and Deceptive Acts and Practices Statute (“HUDAPS”). H.R.S. § 480-1.

638. HUDAPS declares that all “[u]nfair methods of competition and unfair or deceptive acts or practices in the conduct of any trade or commerce are unlawful.” H.R.S. § 480.2(a). Defendants engaged in unlawful trade practices, and unfair or deceptive acts or practices that violated the HUDAPS.

639. In the course of their business, Defendants concealed and suppressed material facts concerning the Fuel Pump Defect. Defendants falsely represented the quality of the Affected Vehicles and omitted material facts regarding the fuel pump, as well as the durability and overall value of the Affected Vehicles, for the purpose of inducing Plaintiff and other Hawaii Subclass members to purchase the Affected Vehicles, and to increase Defendants’ revenue and profits.

640. The facts concealed and omitted by Defendant were material in that a reasonable consumer would have considered them to be important in deciding whether to purchase or lease the Affected Vehicles or pay a lower price. Had Plaintiff and other Hawaii Subclass members known of the Fuel Pump Defect, she would not have purchased or leased those vehicles, or would have paid substantially less for the vehicles than she did.

641. Plaintiff and the other Class members were injured and suffered ascertainable loss, injury in fact, and/or actual damages as a proximate result of Defendants' conduct in that Plaintiff and the other Class members overpaid for their Affected Vehicles and did not get the benefit of her bargain, and her Affected Vehicles have suffered a diminution in value. These injuries are the direct and natural consequence of Subaru's misrepresentations, fraud, deceptive practices, and omissions. Defendants' violations present a continuing risk to Plaintiff as well as to the general public. Defendants' unlawful acts and practices complained of herein affect the public interest.

642. Defendants are liable to Plaintiff and Hawaii Class members for treble her actual damages, reasonable fees and costs, injunctive and such other relief this Court deems appropriate. H.R.S. § 480-13(b)(1), (b)(2), and (c).

COUNT XXV

VIOLATIONS OF HAWAII'S UNIFORM DECEPTIVE TRADE PRACTICES ACT (H.R.S. § 4801A-1 *ET SEQ.*) (As to all Defendants)

643. Plaintiff Anderson (for the purposes of the next three counts, "Plaintiff") incorporates by reference all paragraphs as though fully set forth herein.

644. Plaintiff brings this Count on behalf of the Hawaii Class members.

645. Defendants are each "persons" for the purposes of the Plaintiff and other Class members are "consumers" for the purposes of the Hawaii's Uniform Deceptive Trade Practices Act ("HUDTPA"). H.R.S. § 481A-2.

646. Defendants violated the HUDTPA by misrepresenting and omitting material facts regarding the Affected Vehicles, and by engaging in the following proscribed practices in transactions that were intended to result in the sale of Defendants' products: representing the products have characteristics they do not have; representing their products as being of a particular

standard, quality or grade when they are of another; advertising their products with intent not to sell them as advertised; and engaging in any conduct which similarly creates a likelihood of confusion or misunderstanding. H.R.S. § 481A-3.

647. In the course of their business, Defendants concealed and suppressed material facts concerning the Fuel Pump Defect. Defendants falsely represented the quality of the Affected Vehicles and omitted material facts regarding the fuel pump, as well as the durability and overall value of the Affected Vehicles, for the purpose of inducing Plaintiff and other Hawaii Subclass members to purchase the Affected Vehicles, and to increase Defendants' revenue and profits.

648. The facts concealed and omitted by Defendant were material in that a reasonable consumer would have considered them to be important in deciding whether to purchase or lease the Affected Vehicles or pay a lower price. Had Plaintiff and other Hawaii Subclass members known of the Fuel Pump Defect, she would not have purchased or leased those vehicles, or would have paid substantially less for the vehicles than she did.

649. Plaintiff and the other Class members were injured and suffered ascertainable loss, injury in fact, and/or actual damages as a proximate result of Defendants' conduct in that Plaintiff and the other Class members overpaid for their Affected Vehicles and did not get the benefit of her bargain, and her Affected Vehicles have suffered a diminution in value. These injuries are the direct and natural consequence of Subaru's misrepresentations, fraud, deceptive practices, and omissions. Defendants' violations present a continuing risk to Plaintiff as well as to the general public. Defendants' unlawful acts and practices complained of herein affect the public interest.

650. Defendants should be enjoined and ordered to extend repair remedies to all members of the Subclass and awarding restitution and disgorgement. H.R.S. § 481A-4(a). Plaintiffs should be awarded fees and costs. H.R.S. § 481A-4(b).

COUNT XXVI

BREACH OF IMPLIED WARRANTY OF MERCHANTABILITY

(H.R.S. § 490:2-314)

(As to Subaru)

651. Plaintiff incorporate by reference all paragraphs as though fully set forth herein.

652. Plaintiff brings this Count on behalf of the Hawaii Subclass members.

653. Defendant is a merchant with respect to motor vehicles under H.R.S. § 490:2-314.

654. Under H.R.S. § 490:2-314, a warranty that the Affected Vehicles were in merchantable condition was implied by law in the transactions when purchased or leased their Affected Vehicles from Subaru.

655. The Affected Vehicles, when sold and at all times thereafter, were not merchantable and are not fit for the ordinary purpose for which cars are used.

656. Subaru marketed the Affected Vehicles as safe, reliable, and high quality automobiles that would function as reasonably expected by consumers and in accordance with industry standards. Such representations formed the basis of the bargain in Plaintiff's and Pennsylvania Subclass members' decisions to purchase the Affected Vehicles.

657. Plaintiffs and other Hawaii Subclass members purchased the Affected Vehicles from Subaru, or through Subaru's authorized agents for retail sales. At all relevant times, Subaru was the manufacturer, distributor, warrantor, and/or seller of the Affected Vehicles.

658. Subaru knew or had reason to know of the specific use for which the Affected Vehicles were purchased.

659. Because of the Fuel Pump Defect, the Affected Vehicles were not in merchantable condition when sold and are not fit for the ordinary purpose of providing safe and reliable transportation.

660. Subaru knew about the defect in the Affected Vehicles, allowing Subaru to cure their breach of warranty if it chose to do so.

661. Subaru's attempt to disclaim or limit the implied warranty of merchantability vis-à-vis consumers is unconscionable and unenforceable here. Specifically, Subaru's warranty limitations are unenforceable because they knowingly sold a defective product without informing consumers about the defect. The time limits contained in Subaru's warranty periods were also unconscionable and inadequate to protect Plaintiff and other Hawaii Subclass members. Among other things, Plaintiff and other Hawaii Subclass members had no meaningful choice in determining these time limitations, the terms of which unreasonably favored Subaru. A gross disparity in bargaining power existed between Subaru and Hawaii Subclass members, and Subaru knew of the defect at the time of sale.

662. Plaintiff and Hawaii Subclass members have complied with all obligations under the warranty, or otherwise have been excused from performance of said obligations as a result of Subaru's conduct described herein. Affording Subaru a reasonable opportunity to cure the breach of written warranties therefore would be unnecessary and futile.

663. Subaru was provided notice of these issues by numerous complaints filed against it, internal investigations, postings on websites, and other sources.

664. As a direct and proximate result of Subaru's breach of the implied warranty of merchantability, Plaintiff and the Class have been damaged in an amount to be proven at trial

H. Claims Brought on Behalf of the Illinois Subclass

COUNT XXVII

**VIOLATION OF THE ILLINOIS CONSUMER FRAUD
AND DECEPTIVE BUSINESS PRACTICES ACT
(815 ILL. COMP. STAT. 505/1 ET. SEQ.)
(As to all Defendants)**

665. Plaintiff Kravchenko (for purposes of the next three counts, “Plaintiff”) incorporate by reference all paragraphs as though fully set forth herein.

666. Plaintiff brings this Count on behalf of the Illinois Subclass members.

667. Defendants are each a “person” as that term is defined in 815 Ill. Comp. Stat. 505/1(c).

668. Plaintiff and the Subclass Members are “consumers” as that term is defined in 815 Ill. Comp. Stat. 505/1(e).

669. The purpose of the Illinois Consumer Fraud and Deceptive Business Practices Act (“Illinois CFA”) is to enjoin trade practices which confuse or deceive the consumer. The Illinois CFA prohibits “unfair or deceptive acts or practices, including but not limited to the use or employment of any deception, fraud, false pretense, false promise, misrepresentation or the concealment, suppression, or omission of such material fact ... in the conduct of trade or commerce ... whether any person has in fact been misled, deceived or damaged thereby.” 815 Ill. Comp. Stat. 505/2.

670. The facts concealed and omitted by Defendants were material in that a reasonable consumer would have considered them to be important in deciding whether to purchase or lease the Affected Vehicles or pay a lower price. Had Plaintiff and other Illinois Subclass members known of the Fuel Pump Defect, they would not have purchased or leased those vehicles, or would have paid substantially less for the vehicles than they did.

671. Defendants’ conduct proximately caused injuries to Plaintiff and the other Illinois Subclass members.

672. Plaintiff and the other Illinois Subclass members were injured and suffered ascertainable loss, injury in fact, and/or actual damage as a proximate result of Defendants’

conduct in that Plaintiff and the other Illinois Subclass members overpaid for their Affected Vehicles and did not receive the benefit of their bargain, and their Affected Vehicles have suffered a diminution in value. These injuries are the direct and natural consequence of Defendants' misrepresentations, fraud, deceptive practices, and omissions.

673. Defendants' violations present a continuing risk to Plaintiff as well as to the general public. Subaru's unlawful acts and practices complained of herein affect the public interest. Subaru's violations present a continuing risk to Plaintiff as well as to the general public. Defendants' unlawful acts and practices complained of herein affect the public interest.

674. Pursuant to 815 Ill. Comp. Stat. 505/10a(a), Plaintiff and the Class members seek monetary relief against Defendants in the amount of actual damages, as well as punitive damages because Subaru acted with fraud and/or malice and/or was grossly negligent.

675. Plaintiff also seeks attorneys' fees, and any other just and proper relief available under 815 Ill. Comp. Stat. § 505/1 et. seq.

COUNT XXVIII

BREACH OF THE IMPLIED WARRANTY FOR MERCHANTABILITY (810 ILL. COMP. STAT. 5/2-314) (As to Subaru)

676. Plaintiff incorporate by reference all paragraphs as though fully set forth herein.

677. Plaintiff bring this Count on behalf of the Illinois Subclass members.

678. Subaru is a merchant with respect to motor vehicles within the meaning of the 810 Ill. Comp. Stat. 5/2-314.

679. Under 810 Ill. Comp. Stat. 5/2-314, a warranty that the Affected Vehicles were in merchantable condition was implied by law in the transactions when Plaintiff and other Class members purchased or leased their Affected Vehicles.

680. The Affected Vehicles, when sold and at all times thereafter, were not merchantable and are not fit for the ordinary purpose for which cars are used.

681. Subaru marketed the Affected Vehicles as safe, reliable, and high quality automobiles that would function as reasonably expected by consumers and in accordance with industry standards. Such representations formed the basis of the bargain in Plaintiff's and Illinois Subclass members' decisions to purchase the Affected Vehicles.

682. Plaintiff and other Illinois Subclass members purchased the Affected Vehicles from Subaru, or through Subaru's authorized agents for retail sales. At all relevant times, Subaru was the manufacturer, distributor, warrantor, and/or seller of the Affected Vehicles.

683. Subaru knew or had reason to know of the specific use for which the Affected Vehicles were purchased.

684. Because of the Fuel Pump Defect, the Affected Vehicles were not in merchantable condition when sold and are not fit for the ordinary purpose of providing safe and reliable transportation.

685. Subaru knew about the defect in the Affected Vehicles, allowing Subaru to cure their breach of warranty if it chose to do so.

686. Subaru's attempt to disclaim or limit the implied warranty of merchantability vis-à-vis consumers is unconscionable and unenforceable here. Specifically, Subaru's warranty limitations are unenforceable because they knowingly sold a defective product without informing consumers about the defect. The time limits contained in Subaru's warranty periods were also unconscionable and inadequate to protect Plaintiff and other Illinois Subclass members. Among other things, Plaintiff and other Illinois Subclass members had no meaningful choice in determining these time limitations, the terms of which unreasonably favored Subaru. A gross

disparity in bargaining power existed between Subaru and Illinois Subclass members, and Subaru knew of the defect at the time of sale.

687. Plaintiff and Illinois Subclass members have complied with all obligations under the warranty, or otherwise have been excused from performance of said obligations as a result of Subaru's conduct described herein. Affording Subaru a reasonable opportunity to cure the breach of written warranties therefore would be unnecessary and futile.

688. Subaru was provided notice of these issues by numerous complaints filed against it, internal investigations, postings on websites, and other sources.

689. As a direct and proximate result of Subaru's breach of the implied warranty of merchantability, Plaintiff and the Class have been damaged in an amount to be proven at trial.

I. Claims Brought on Behalf of the Maryland Subclass

COUNT XXIX

**VIOLATIONS OF THE MARYLAND CONSUMER PROTECTION ACT
(MD. CODE ANN. COM. LAW. § 13-101 ET SEQ.)
(As to all Defendants)**

690. Plaintiffs Efantis and Fontenot (for purposes of the next two counts, "Plaintiffs") incorporate by reference all paragraphs as though fully set forth herein.

691. Plaintiffs bring this Count on behalf of the Maryland Subclass members.

692. Defendants, Plaintiffs, and other Class members are "persons" within the meaning of Md. Code Ann., Com. Law § 13-101(h).

693. The Maryland Consumer Protection Act ("Maryland Act") provides that a person may not engage in any unfair or deceptive trade practice in the sale or lease of any consumer good. Md. Code Ann., Com. Law Code § 13-303. These include "(1) false, falsely disparaging, or misleading oral or written statement, visual description, or other representations of any kind which has the capacity, tendency, or effect of deceiving or misleading consumers; (2) Representation

that: (i) consumer goods have a sponsorship, approval, accessory, characteristic, ingredient, use, benefit, or quality which they do not have: . . . (iv) Consumer goods, consumer realty, or consumer services are of a particular standard, quality, grade, style, or model which they are not;” and (6) false or misleading representation of fact which concerns; (i) The reason for or the existence of a price reduction; or (ii) A price comparison to a price of a competitor or to one’s price at a past or future time;” and (9) Deception, fraud, false pretense, false promise, misrepresentation, or knowing concealment, suppression, or omission of any material fact with the intent that a consumer rely on the same in connection with: (i) The promotion or sale of any consumer goods.” Subaru participated in misleading, false, deceptive acts that violated the Maryland CPA. By concealing the known defects in Plaintiffs’ Affected Vehicles, Subaru engaged in deceptive business practices prohibited by the Maryland CPA.

694. In the course of their business, Defendants concealed and suppressed material facts concerning the Fuel Pump Defect. Defendants falsely represented the quality of the Affected Vehicles and omitted material facts regarding the fuel pump, as well as the durability and overall value of the Affected Vehicles, for the purpose of inducing Plaintiffs and other Maryland Subclass members to purchase the Affected Vehicles, and to increase Defendants’ revenue and profits.

695. The facts concealed and omitted by Defendants were material in that a reasonable consumer would have considered them to be important in deciding whether to purchase or lease the Affected Vehicles or pay a lower price. Had Plaintiffs and other Maryland Subclass members known of the Fuel Pump Defect, they would not have purchased or leased those vehicles, or would have paid substantially less for the vehicles than they did.

696. Defendants’ violations present a continuing risk to Plaintiffs as well as to the general public. Defendants’ unlawful acts and practices complained of herein affect the public

interest. As a direct and proximate result of Subaru's breach of the implied warranty of merchantability, Plaintiffs and the Class have been damaged in an amount to be proven at trial.

COUNT XXX

**BREACH OF IMPLIED WARRANTY OF MERCHANTABILITY
(MD. CODE COM. LAW § 2-314)
(As to Subaru)**

697. Plaintiffs incorporate by reference all paragraphs as though fully set forth herein.

698. Plaintiffs bring this Count on behalf of the Maryland Class members.

699. Subaru is a merchant with respect to motor vehicles within the meaning of the Md. Code Com. Law § 2-314.

700. Under Md. Code Com. Law § 2-314, a warranty that the Affected Vehicles were in merchantable condition was implied by law in the transactions when Plaintiffs purchased or leased their Affected Vehicles from Subaru.

701. The Affected Vehicles, when sold and at all times thereafter, were not merchantable and are not fit for the ordinary purpose for which cars are used.

702. Subaru marketed the Affected Vehicles as safe, reliable, and high quality automobiles that would function as reasonably expected by consumers and in accordance with industry standards. Such representations formed the basis of the bargain in Plaintiffs' and Maryland Subclass members' decisions to purchase the Affected Vehicles.

703. Plaintiffs and other Maryland Subclass members purchased the Affected Vehicles from Subaru, or through Subaru's authorized agents for retail sales. At all relevant times, Subaru was the manufacturer, distributor, warrantor, and/or seller of the Affected Vehicles.

704. Subaru knew or had reason to know of the specific use for which the Affected Vehicles were purchased.

705. Because of the Fuel Pump Defect, the Affected Vehicles were not in merchantable condition when sold and are not fit for the ordinary purpose of providing safe and reliable transportation.

706. Subaru knew about the defect in the Affected Vehicles, allowing Subaru to cure their breach of warranty if it chose to do so.

707. Subaru's attempt to disclaim or limit the implied warranty of merchantability vis-à-vis consumers is unconscionable and unenforceable here. Specifically, Subaru's warranty limitations are unenforceable because they knowingly sold a defective product without informing consumers about the defect. The time limits contained in Subaru's warranty periods were also unconscionable and inadequate to protect Plaintiffs and other Maryland Subclass members. Among other things, Plaintiffs and other Maryland Subclass members had no meaningful choice in determining these time limitations, the terms of which unreasonably favored Subaru. A gross disparity in bargaining power existed between Subaru and Maryland Subclass members, and Subaru knew of the defect at the time of sale.

708. Plaintiffs and Maryland Subclass members have complied with all obligations under the warranty, or otherwise have been excused from performance of said obligations as a result of Subaru's conduct described herein. Affording Subaru a reasonable opportunity to cure the breach of written warranties therefore would be unnecessary and futile.

709. Subaru was provided notice of these issues by numerous complaints filed against it, internal investigations, postings on websites, and other sources.

710. As a direct and proximate result of Subaru's breach of the implied warranty of merchantability, Plaintiffs and the Class have been damaged in an amount to be proven at trial.

J. Claims Brought on Behalf of the Massachusetts Subclass

COUNT XXXI

**VIOLATION OF THE MASSACHUSETTS CONSUMER PROTECTION ACT
(MASS. GEN. LAWS ANN. CH 93A, § 1 *ET SEQ.*)
(As to all Defendants)**

711. Plaintiff Paula Weeks (“Plaintiff,” for purposes of the next two counts) incorporates by reference all paragraphs as though full set forth herein.

712. Plaintiff brings this Count on behalf of the Massachusetts Subclass members.

713. Defendant is a person under the Massachusetts Consumer Protection Act (Massachusetts CPA). Mass. Gen. Laws Ann. Ch 93A, § 1(a).

714. The Massachusetts CPA prohibits all “unfair methods of competition and unfair or deceptive acts or practices in the conduct of trade or commerce” Mass. Gen. Laws Ann. Ch 93A, § 2(a).

715. Defendants engaged in unfair and deceptive practices through the course of its representations and omissions relating to Affected Vehicles and its conduct of its recall, as alleged above.

716. The facts concealed and omitted by Defendants were material in that a reasonable consumer would have considered them to be important in deciding whether to purchase or lease the Affected Vehicles or pay a lower price. Had Plaintiff and other Massachusetts Subclass members known of the Fuel Pump Defect, they would not have purchased or leased those vehicles, or would have paid substantially less for the vehicles than they did.

717. Defendants’ conduct proximately caused injuries to Plaintiff and the other Massachusetts Subclass members.

718. Plaintiff and the other Massachusetts Subclass members were injured and suffered ascertainable loss, injury in fact, and/or actual damage as a proximate result of Defendants’

conduct in that Plaintiff and the other Massachusetts Subclass members overpaid for their Affected Vehicles and did not receive the benefit of their bargain, and their Affected Vehicles have suffered a diminution in value. These injuries are the direct and natural consequence of Defendants' misrepresentations, fraud, deceptive practices, and omissions.

719. Defendants' violations present a continuing risk to Plaintiff as well as to the general public. Defendants' unlawful acts and practices complained of herein affect the public interest.

720. Plaintiff and the Class members are entitled to recover up to treble damages and attorneys' fees and costs. Mass. Gen. Laws Ann. Ch 93A, § 9.

COUNT XXXII

BREACH OF IMPLIED WARRANTY OF MERCHANTABILITY (MASS. GEN. LAWS ANN. CH 106, § 2-314) (As to Subaru)

721. Plaintiff incorporates by reference all paragraphs as though fully set forth herein.

722. Plaintiff bring this Count on behalf of the Massachusetts Subclass members.

723. Subaru is a merchant with respect to motor vehicles under Mass. Gen. Laws. Ann. ch 106, § 2-314.

724. Under Mass. Gen. Laws. Ann. ch 106, § 2-314., a warranty that the Affected Vehicles were in merchantable condition was implied by law in the transactions when Plaintiff and Class members purchased or leased their Affected Vehicles from Subaru.

725. The Affected Vehicles, when sold and at all times thereafter, were not merchantable and are not fit for the ordinary purpose for which cars are used.

726. Subaru marketed the Affected Vehicles as safe, reliable, and high quality automobiles that would function as reasonably expected by consumers and in accordance with industry standards. Such representations formed the basis of the bargain in Plaintiff's and Massachusetts Subclass members' decisions to purchase the Affected Vehicles.

727. Plaintiff and other Massachusetts Subclass members purchased the Affected Vehicles from Subaru, or through Subaru's authorized agents for retail sales. At all relevant times, Subaru was the manufacturer, distributor, warrantor, and/or seller of the Affected Vehicles.

728. Subaru knew or had reason to know of the specific use for which the Affected Vehicles were purchased.

729. Because of the Fuel Pump Defect, the Affected Vehicles were not in merchantable condition when sold and are not fit for the ordinary purpose of providing safe and reliable transportation.

730. Subaru knew about the defect in the Affected Vehicles, allowing Subaru to cure their breach of warranty if it chose to do so.

731. Subaru's attempt to disclaim or limit the implied warranty of merchantability vis-à-vis consumers is unconscionable and unenforceable here. Specifically, Subaru's warranty limitations are unenforceable because they knowingly sold a defective product without informing consumers about the defect. The time limits contained in Subaru's warranty periods were also unconscionable and inadequate to protect Plaintiff and other Massachusetts Subclass members. Among other things, Plaintiff and other Massachusetts Subclass members had no meaningful choice in determining these time limitations, the terms of which unreasonably favored Subaru. A gross disparity in bargaining power existed between Subaru and Massachusetts Subclass members, and Subaru knew of the defect at the time of sale.

732. Plaintiff and Massachusetts Subclass members have complied with all obligations under the warranty, or otherwise have been excused from performance of said obligations as a result of Subaru's conduct described herein. Affording Subaru a reasonable opportunity to cure the breach of written warranties therefore would be unnecessary and futile.

733. Subaru was provided notice of these issues by numerous complaints filed against it, internal investigations, postings on websites, and other sources.

734. As a direct and proximate result of Subaru's breach of the implied warranty of merchantability, Plaintiff and the Class have been damaged in an amount to be proven at trial.

K. Claims Brought on Behalf of the Minnesota Subclass

COUNT XXIII

**VIOLATION OF THE MINNESOTA PREVENTION OF CONSUMER FRAUD ACT
(MINN. STAT. § 325F.68 *ET SEQ.*)
(As to all Defendants)**

735. Plaintiff John Micklo (for purposes of the next three counts, "Plaintiff") incorporates by reference all paragraphs as though fully set forth herein.

736. Plaintiff brings this Count on behalf of the Minnesota Subclass members.

737. The Affected Vehicles constitute "merchandise" within the meaning of Minn. Stat. § 325F.68(2).

738. The Minnesota Prevention of Consumer Fraud Act ("Minnesota CFA") prohibits "[t]he act, use, or employment by any person of any fraud, false pretense, false promise, misrepresentation, misleading statement or deceptive practice, with the intent that others rely thereon in connection with the sale of any merchandise, whether or not any person has in fact been misled, deceived, or damaged thereby." Minn. Stat. § 325F.69.

739. In the course of their business, Defendants concealed and suppressed material facts concerning the Fuel Pump Defect. Defendants falsely represented the quality of the Affected Vehicles and omitted material facts regarding the fuel pump, as well as the durability and overall value of the Affected Vehicles, for the purpose of inducing Plaintiff and other Minnesota Subclass members to purchase the Affected Vehicles, and to increase Defendants' revenue and profits.

740. The facts concealed and omitted by Defendants were material in that a reasonable consumer would have considered them to be important in deciding whether to purchase or lease the Affected Vehicles or pay a lower price. Had Plaintiff and other Minnesota Subclass members known of the Fuel Pump Defect, they would not have purchased or leased those vehicles, or would have paid substantially less for the vehicles than they did.

741. Defendants' violations present a continuing risk to Plaintiff as well as to the general public. Defendants' unlawful acts and practices complained of herein affect the public interest.

742. Pursuant to Minn. Stat. § 8.31(3a), Plaintiff and Minnesota Subclass seek actual damages, attorneys' fees, and any other just and proper relief available under the Minnesota CFA.

743. Plaintiff also seeks punitive damages under Minn. Stat. § 549.20(1)(a) given the clear and convincing evidence that Defendants' acts show deliberate disregard for the rights of others.

COUNT XXXIV

BREACH OF IMPLIED WARRANTY OF MERCHANTABILITY (MINN. STAT. § 336.2-314) (As to Subaru)

744. Plaintiff incorporates by reference all paragraphs as though fully set forth herein.

745. Plaintiff brings this Count on behalf of the Minnesota Subclass members.

746. Subaru is a merchant with respect to motor vehicles within the meaning of the Minn. Stat. § 336.2-314.

747. Under Minn. Stat. § 336.2-314, a warranty that the Affected Vehicles were in merchantable condition was implied by law in the transactions when Plaintiff and Minnesota Subclass members purchased or leased their Affected Vehicles from Subaru.

748. The Affected Vehicles, when sold or leased and at all times thereafter, were not merchantable and are not fit for the ordinary purpose for which vehicles are used.

749. The Affected Vehicles, when sold and at all times thereafter, were not merchantable and are not fit for the ordinary purpose for which cars are used.

750. Subaru marketed the Affected Vehicles as safe, reliable, and high quality automobiles that would function as reasonably expected by consumers and in accordance with industry standards. Such representations formed the basis of the bargain in Plaintiff's and Minnesota Subclass members' decisions to purchase the Affected Vehicles.

751. Plaintiff and other Minnesota Subclass members purchased the Affected Vehicles from Subaru, or through Subaru's authorized agents for retail sales. At all relevant times, Subaru was the manufacturer, distributor, warrantor, and/or seller of the Affected Vehicles.

752. Subaru knew or had reason to know of the specific use for which the Affected Vehicles were purchased.

753. Because of the Fuel Pump Defect, the Affected Vehicles were not in merchantable condition when sold and are not fit for the ordinary purpose of providing safe and reliable transportation.

754. Subaru knew about the defect in the Affected Vehicles, allowing Subaru to cure their breach of warranty if it chose to do so.

755. Subaru's attempt to disclaim or limit the implied warranty of merchantability vis-à-vis consumers is unconscionable and unenforceable here. Specifically, Subaru's warranty limitations are unenforceable because they knowingly sold a defective product without informing consumers about the defect. The time limits contained in Subaru's warranty periods were also unconscionable and inadequate to protect Plaintiff and other Minnesota Subclass members.

Among other things, Plaintiff and other Minnesota Subclass members had no meaningful choice in determining these time limitations, the terms of which unreasonably favored Subaru. A gross disparity in bargaining power existed between Subaru and Minnesota Subclass members, and Subaru knew of the defect at the time of sale.

756. Plaintiff and Minnesota Subclass members have complied with all obligations under the warranty, or otherwise have been excused from performance of said obligations as a result of Subaru's conduct described herein. Affording Subaru a reasonable opportunity to cure the breach of written warranties therefore would be unnecessary and futile.

757. Subaru was provided notice of these issues by numerous complaints filed against it, internal investigations, postings on websites, and other sources.

758. Accordingly, Subaru is liable to Plaintiff and Minnesota Subclass members for damages in an amount to be proven at trial.

COUNT XXXV

BREACH OF COVENANT OF GOOD FAITH AND FAIR DEALING (BASED ON MINNESOTA STATE LAW) (As to Subaru)

759. Plaintiff incorporates by reference all preceding allegations as though fully set forth herein.

760. Plaintiff brings this Count on behalf of himself and all similarly situated residents of the state of Minnesota.

761. Plaintiff and Minnesota Subclass members entered into contracts with Subaru in connection with the sale of the Affected Vehicles.

762. Plaintiff and Minnesota Subclass members gave fair and reasonable consideration and performed all their material obligations under the contracts.

763. Implied in all contracts is a covenant of good faith and fair dealing, imposing a duty on the parties to act in good faith and deal fairly with one another.

764. Plaintiff and Minnesota Subclass members had a reasonable expectation that when they purchased their Affected Vehicles from Subaru, the Affected Vehicles would be free of defects, especially defects that affected the safety and operability of the Affected Vehicles.

765. Subaru made the decision to place inferior low-pressure fuel pumps into the Affected Vehicles without informing Plaintiff and Minnesota Subclass members that the inferior technology would create a safety defect in the Affected Vehicles.

766. Plaintiff and Minnesota Subclass members had no reason to know Subaru had placed inferior low-pressure fuel pumps into the Affected Vehicles.

767. By creating and promoting an automobile with a latent safety defect, Subaru breached the covenant of good faith and fair dealing and breached its contractual duty to Plaintiff and Minnesota Subclass members.

768. As a direct and proximate result of Subaru's breach, Plaintiff and Minnesota Subclass members suffered damages, including being induced to purchase the defective Affected Vehicles.

L. Claims Brought on Behalf of the Nevada Subclass

COUNT XXXVI

**VIOLATIONS OF THE NEVADA DECEPTIVE TRADE PRACTICES ACT
(NEV.REV. STAT. § 598.0903 *ET SEQ.*)
(As to all Defendants)**

769. Plaintiff Srolev (for the purposes of the next two counts, "Plaintiff") incorporates by reference all paragraphs as though fully set forth herein.

770. Plaintiff brings this Count on behalf of the Nevada Class members.

771. The Nevada Deceptive Trade Practices Act prohibits “Represent[ing] that goods or services for sale or lease are of a particular standard, quality or grade, or that such goods are of a particular style or model, if he or she knows or should know that they are of another standard, quality, grade, style or model.” Nev. Rev. Stat. Ann. § 598.0915(7). NDTPA further prohibits “[k]nowingly makes a false representation as to the characteristics, ingredients, uses, benefits, alterations or quantities of goods or services for sale or lease” Nev. Rev. Stat. Ann. § 598.0915(5).

772. In the course of their business, Defendants concealed and suppressed material facts concerning the Fuel Pump Defect. Defendants falsely represented the quality of the Affected Vehicles and omitted material facts regarding the fuel pump, as well as the durability and overall value of the Affected Vehicles, for the purpose of inducing Plaintiff and other Nevada Subclass members to purchase the Affected Vehicles, and to increase Defendants’ revenue and profits.

773. The facts concealed and omitted by Defendant were material in that a reasonable consumer would have considered them to be important in deciding whether to purchase or lease the Affected Vehicles or pay a lower price. Had Plaintiff and other Nevada Subclass members known of the Fuel Pump Defect, she would not have purchased or leased those vehicles, or would have paid substantially less for the vehicles than she did.

774. Plaintiff and the other Class members were injured and suffered ascertainable loss, injury in fact, and/or actual damages as a proximate result of Defendants’ conduct in that Plaintiff and the other Class members overpaid for their Affected Vehicles and did not get the benefit of her bargain, and her Affected Vehicles have suffered a diminution in value. These injuries are the direct and natural consequence of Defendants’ misrepresentations, fraud, deceptive practices, and

omissions. Defendants' violations present a continuing risk to Plaintiff as well as to the general public. Defendants' unlawful acts and practices complained of herein affect the public interest.

775. Defendants are liable to Plaintiff and Nevada Class members for actual damages. Plaintiff and other Class members are also entitled to an award of punitive damages given that Defendants' conduct was malicious, wanton, willful, oppressive, or exhibited a reckless indifference to the rights of others as well as fees and costs.

COUNT XXXVII

BREACH OF IMPLIED WARRANTY OF MERCHANTABILITY (NEV. REV. STAT. § 104.2314) (As to Subaru)

776. Plaintiff incorporates by reference all paragraphs as though fully set forth herein.

777. Plaintiff brings this Count on behalf of the Nevada Subclass members.

778. Subaru is a merchant with respect to motor vehicles under Nev. Rev. Stat. Ann. § 104.2104.

779. Under Nev. Rev. Stat. Ann. § 104.2314, a warranty that the Affected Vehicles were in merchantable condition was implied by law in the transactions when purchased or leased their Affected Vehicles from Subaru.

780. The Affected Vehicles, when sold and at all times thereafter, were not merchantable and are not fit for the ordinary purpose for which cars are used.

781. Subaru marketed the Affected Vehicles as safe, reliable, and high quality automobiles that would function as reasonably expected by consumers and in accordance with industry standards. Such representations formed the basis of the bargain in Plaintiff's and Nevada Subclass members' decisions to purchase the Affected Vehicles.

782. Plaintiff and other Nevada Subclass members purchased the Affected Vehicles from Subaru, or through Subaru's authorized agents for retail sales. At all relevant times, Subaru was the manufacturer, distributor, warrantor, and/or seller of the Affected Vehicles.

783. Subaru knew or had reason to know of the specific use for which the Affected Vehicles were purchased.

784. Because of the Fuel Pump Defect, the Affected Vehicles were not in merchantable condition when sold and are not fit for the ordinary purpose of providing safe and reliable transportation.

785. Subaru knew about the defect in the Affected Vehicles, allowing Subaru to cure their breach of warranty if it chose to do so.

786. Subaru's attempt to disclaim or limit the implied warranty of merchantability vis-à-vis consumers is unconscionable and unenforceable here. Specifically, Subaru's warranty limitations are unenforceable because they knowingly sold a defective product without informing consumers about the defect. The time limits contained in Subaru's warranty periods were also unconscionable and inadequate to protect Plaintiff and other Nevada Subclass members. Among other things, Plaintiff and other Nevada Subclass members had no meaningful choice in determining these time limitations, the terms of which unreasonably favored Subaru. A gross disparity in bargaining power existed between Subaru and Nevada Subclass members, and Subaru knew of the defect at the time of sale.

787. Plaintiff and Nevada Subclass members have complied with all obligations under the warranty, or otherwise have been excused from performance of said obligations as a result of Subaru's conduct described herein. Affording Subaru a reasonable opportunity to cure the breach of written warranties therefore would be unnecessary and futile.

788. Subaru was provided notice of these issues by numerous complaints filed against it, internal investigations, postings on websites, and other sources.

789. As a direct and proximate result of Subaru's breach of the implied warranty of merchantability, Plaintiff and the Class have been damaged in an amount to be proven at trial.

M. Claims Brought on Behalf of the New York Subclass

COUNT XXXVII

**VIOLATIONS OF NEW YORK GENERAL BUSINESS LAW § 349
(N.Y. GEN. BUS. LAW § 349)
(As to all Defendants)**

790. Plaintiffs Moore, Plante, and Karrat ("Plaintiffs," for purposes of the next four counts) incorporate by reference all paragraphs as though fully set forth herein.

791. Plaintiffs bring this Count on behalf of the New York Subclass members.

792. Plaintiffs are "persons" within the meaning of New York General Business Law ("New York GBL"). N.Y. Gen. Bus. Law § 349(h).

793. Defendants are each a "person," "firm," "corporation," or "association" within the meaning of N.Y. Gen. Bus. Law § 349.

794. New York's General Business Law § 349 makes unlawful "[d]eceptive acts or practices in the conduct of any business, trade or commerce." N.Y. Gen. Bus. Law § 349. Subaru's conduct, as described in this Complaint, constitutes "deceptive acts or practices" within the meaning of New York GBL. All of Defendants' deceptive acts or practices, which were intended to mislead consumers in a material way in the process of purchasing or leasing Affected Vehicles, was conduct directed at consumers and "consumer-oriented." Further, Plaintiffs and other Class members suffered injury as a result of the deceptive act or practice.

795. In the course of its business, Defendants concealed and suppressed material facts concerning the Fuel Pump Defect. Defendants falsely represented the quality of the Affected

Vehicles and omitted material facts regarding the fuel pump, as well as the durability and overall value of the Affected Vehicles, for the purpose of inducing Plaintiffs and other New York Subclass members to purchase the Affected Vehicles, and to increase Defendants' revenue and profits.

796. The facts concealed and omitted by Defendant were material in that a reasonable consumer would have considered them to be important in deciding whether to purchase or lease the Affected Vehicles or pay a lower price. Had Plaintiffs and other New York Subclass members known of the Fuel Pump Defect, they would not have purchased or leased those vehicles, or would have paid substantially less for the vehicles than they did.

797. Plaintiffs and the other Class members were injured and suffered ascertainable loss, injury in fact, and/or actual damages as a proximate result of Defendants' conduct in that Plaintiffs and the other Class members overpaid for their Affected Vehicles and did not get the benefit of their bargain, and their Affected Vehicles have suffered a diminution in value. These injuries are the direct and natural consequence of Subaru's misrepresentations, fraud, deceptive practices, and omissions.

798. Defendants' violations present a continuing risk to Plaintiffs as well as to the general public. Subaru's unlawful acts and practices complained of herein affect the public interest. Specifically: (1) the number of consumers affected by Defendants' deceptive practices are in the hundreds of thousands nation-wide; (2) Subaru has significantly high sophistication and bargaining power with respect to the manufacture and sale of the Affected Vehicles to Plaintiffs and individual Class members; and (3) so long as the Affected Vehicles continued to be sold and distributed, the likelihood of continued impact on other consumers is significant.

799. Pursuant to N.Y. Gen. Bus. Law § 349(h), Plaintiffs and the Class seek actual damages or \$50, whichever is greater, in addition to discretionary three times actual damages up

to \$1,000 for Defendants' willful and knowing violation of N.Y. Gen. Bus. Law § 349. Plaintiffs and New York Class members also seek attorneys' fees, an order enjoining Defendants' deceptive conduct, and any other just and proper relief available under the New York GBL.

COUNT XXXVIII

**VIOLATIONS OF NEW YORK GENERAL BUSINESS LAW § 350
(N.Y. GEN. BUS. LAW § 350)
(As to Subaru)**

800. Plaintiffs incorporate by reference all paragraphs as though fully set forth herein.

801. Plaintiffs bring this Count on behalf of the New York Class members.

802. Subaru was engaged in the "conduct of business, trade or commerce" within the meaning of the New York's General Business Law § 350.

803. New York's General Business Law § 350 makes unlawful "[f]alse advertising in the conduct of any business, trade or commerce[.]" False advertising includes "advertising, including labeling, of a commodity ... if such advertising fails to reveal facts material in the light of ... representations [made] with respect to the commodity." N.Y. Gen. Bus. Law § 350-a.

804. Subaru caused to be made or disseminated throughout New York, through advertising, marketing, and other publications, statements that were untrue or misleading, and which were known, or which by the exercise of reasonable care should have been known to Subaru, to be untrue and misleading to consumers, including Plaintiffs and other Class members.

805. Subaru has violated N.Y. Gen. Bus. Law § 350 because of the misrepresentations and omissions alleged herein, including, but not limited to, Subaru's failure to disclose the heightened incompatibility of the Bosch CP4 fuel pump in the Affected Vehicles with US. Diesel fuel such that the normal use of the Affected Vehicles causes metal shards to wear off of the pump and disperse throughout the Class Vehicle's fuel injection system, leading to certain component

wear and potential catastrophic engine failure (oftentimes while the vehicle is in motion, causing a moving stall and subsequent inability to restart the vehicle).

806. In the course of its business, Subaru concealed and suppressed material facts concerning the Fuel Pump Defect. Subaru falsely represented the quality of the Affected Vehicles and omitted material facts regarding the fuel pump, as well as the durability and overall value of the Affected Vehicles, for the purpose of inducing Plaintiffs and other New York Subclass members to purchase the Affected Vehicles, and to increase Subaru's revenue and profits.

807. The facts concealed and omitted by Subaru were material in that a reasonable consumer would have considered them to be important in deciding whether to purchase or lease the Affected Vehicles or pay a lower price. Had Plaintiffs and other New York Subclass members known of the Fuel Pump Defect, they would not have purchased or leased those vehicles, or would have paid substantially less for the vehicles than they did.

808. Plaintiffs and the other Class members were injured and suffered ascertainable loss, injury in fact, and/or actual damages as a proximate result of Subaru's conduct in that Plaintiffs and the other Class members overpaid for their Affected Vehicles and did not get the benefit of their bargain, and their Affected Vehicles have suffered a diminution in value. These injuries are the direct and natural consequence of Subaru's misrepresentations, fraud, deceptive practices, and omissions.

809. Subaru's conduct proximately caused injuries to Plaintiffs and the other Class Members.

810. Plaintiffs and the other Class members were injured and suffered ascertainable loss, injury in fact, and/or actual damages as a proximate result of Subaru's conduct in that Plaintiffs and the other Class members overpaid for their Affected Vehicles and did not get the benefit of

their bargain, and their Affected Vehicles have suffered a diminution in value. These injuries are the direct and natural consequence of Subaru's misrepresentations, fraud, deceptive practices, and omissions. Plaintiffs and the Class are entitled to recover their actual damages or \$500, whichever is greater. Because Subaru acted willfully or knowingly, Plaintiffs and other Class members are entitled to recover three times actual damages, up to \$10,000.

COUNT XXXIX

**BREACH OF IMPLIED WARRANTY OF MERCHANTABILITY
(N.Y. U.C.C. § 2-314)
(As to Subaru)**

811. Plaintiffs incorporate by reference all paragraphs as though fully set forth herein.

812. Plaintiffs bring this Count on behalf of the New York Class members.

813. Subaru is a merchant with respect to motor vehicles within the meaning under N.Y. U.C.C. § 2-314.

814. Under N.Y. U.C.C. § 2-314, a warranty that the Affected Vehicles were in merchantable condition was implied by law in the transactions when Plaintiffs purchased or leased their Affected Vehicles from Subaru.

815. The Affected Vehicles, when sold and at all times thereafter, were not merchantable and are not fit for the ordinary purpose for which cars are used.

816. Subaru marketed the Affected Vehicles as safe, reliable, and high quality automobiles that would function as reasonably expected by consumers and in accordance with industry standards. Such representations formed the basis of the bargain in Plaintiffs' and New York Subclass members' decisions to purchase the Affected Vehicles.

817. Plaintiffs and other New York Subclass members purchased the Affected Vehicles from Subaru, or through Subaru's authorized agents for retail sales. At all relevant times, Subaru was the manufacturer, distributor, warrantor, and/or seller of the Affected Vehicles.

818. Subaru knew or had reason to know of the specific use for which the Affected Vehicles were purchased.

819. Because of the Fuel Pump Defect, the Affected Vehicles were not in merchantable condition when sold and are not fit for the ordinary purpose of providing safe and reliable transportation.

820. Subaru knew about the defect in the Affected Vehicles, allowing Subaru to cure their breach of warranty if it chose to do so.

821. Subaru's attempt to disclaim or limit the implied warranty of merchantability vis-à-vis consumers is unconscionable and unenforceable here. Specifically, Subaru's warranty limitations are unenforceable because they knowingly sold a defective product without informing consumers about the defect. The time limits contained in Subaru's warranty periods were also unconscionable and inadequate to protect Plaintiffs and other New York Subclass members. Among other things, Plaintiffs and other New York Subclass members had no meaningful choice in determining these time limitations, the terms of which unreasonably favored Subaru. A gross disparity in bargaining power existed between Subaru and New York Subclass members, and Subaru knew of the defect at the time of sale.

822. Plaintiffs and New York Subclass members have complied with all obligations under the warranty, or otherwise have been excused from performance of said obligations as a result of Subaru's conduct described herein. Affording Subaru a reasonable opportunity to cure the breach of written warranties therefore would be unnecessary and futile.

823. Subaru was provided notice of these issues by numerous complaints filed against it, internal investigations, postings on websites, and other sources.

824. As a direct and proximate result of Subaru's breach of the implied warranty of merchantability, Plaintiffs and the Class have been damaged in an amount to be proven at trial.

N. Claims Brought on Behalf of the North Carolina Subclass

COUNT XL

**VIOLATIONS OF THE NORTH CAROLINA UNFAIR AND DECEPTIVE
TRADE PRACTICES ACT
(N.C. GEN. STAT. ANN. § 75-1.1 *ET SEQ.*)
(As to all Defendants)**

825. Plaintiff Troy Perry (for purposes of the next two counts, "Plaintiff") incorporates by reference all paragraphs though fully set forth herein.

826. Plaintiff brings this Count on behalf of the North Carolina Subclass members.

827. The North Carolina Unfair Trade Practices Act (N.C.U.T.P.A) makes unlawful all "unfair or deceptive acts or practices in or affecting commerce." N.C. Gen. Stat. Ann. § 75-1.1(a).

828. Defendants engaged in commerce for the purposes of the N.C.U.T.P.A. when marketing, selling and servicing the Affected Vehicles. N.C. Gen. Stat. Ann. § 75-1.1(b).

829. Defendants engaged in unfair and deceptive practices through the course of its representations and omissions relating to Affected Vehicles and its conduct of its recall, as alleged above.

830. The facts concealed and omitted by Defendants were material in that a reasonable consumer would have considered them to be important in deciding whether to purchase or lease the Affected Vehicles or pay a lower price. Had Plaintiff and other North Carolina Subclass members known of the Fuel Pump Defect, they would not have purchased or leased those vehicles, or would have paid substantially less for the vehicles than they did.

831. Defendants' conduct proximately caused injuries to Plaintiff and the other North Carolina Subclass members.

832. Plaintiff and the other North Carolina Subclass members were injured and suffered ascertainable loss, injury in fact, and/or actual damage as a proximate result of Defendants' conduct in that Plaintiff and the other North Carolina Subclass members overpaid for their Affected Vehicles and did not receive the benefit of their bargain, and their Affected Vehicles have suffered a diminution in value. These injuries are the direct and natural consequence of Subaru's misrepresentations, fraud, deceptive practices, and omissions.

833. Defendants' violations present a continuing risk to Plaintiff as well as to the general public. Defendants' unlawful acts and practices complained of herein affect the public interest.

834. Plaintiff and the Class seek monetary relief against Defendants in an amount to be determined at trial. Plaintiff and the Class also seek treble damages because all or part of Subaru's unfair and deceptive acts were done willfully or knowingly. Indeed, Defendants carried out despicable conduct with willful and conscious disregard of the rights of others. Defendants' unlawful conduct constitutes malice, oppression, and fraud warranting punitive damages.

835. Plaintiff also seeks treble damages and, due to the willful nature of the violation, attorneys' fees. N.C. Gen. Stat. Ann. § 75-16, 16.1.

COUNT XLI

BREACH OF THE IMPLIED WARRANTY OF MERCHANTABILITY

(N.C. GEN. STAT. ANN. § 25-2-314)

(As to Subaru)

836. Plaintiff incorporates by reference all paragraphs as though fully set forth herein.

837. Plaintiff brings this Count on behalf of the North Carolina Class members.

838. Subaru is a merchant with respect to motor vehicles within the meaning of the N.C. Gen. Stat. Ann. § 25-2-314.

839. Under N.C. Gen. Stat. Ann. § 25-2-314, a warranty that the Affected Vehicles were in merchantable condition was implied by law in the transactions when Plaintiff and the Class purchased or leased their Affected Vehicles from Subaru.

840. The Affected Vehicles, when sold and at all times thereafter, were not merchantable and are not fit for the ordinary purpose for which cars are used.

841. Subaru marketed the Affected Vehicles as safe, reliable, and high quality automobiles that would function as reasonably expected by consumers and in accordance with industry standards. Such representations formed the basis of the bargain in Plaintiff's and North Carolina Subclass members' decisions to purchase the Affected Vehicles.

842. Plaintiff and other North Carolina Subclass members purchased the Affected Vehicles from Subaru, or through Subaru's authorized agents for retail sales. At all relevant times, Subaru was the manufacturer, distributor, warrantor, and/or seller of the Affected Vehicles.

843. Subaru knew or had reason to know of the specific use for which the Affected Vehicles were purchased.

844. Because of the Fuel Pump Defect, the Affected Vehicles were not in merchantable condition when sold and are not fit for the ordinary purpose of providing safe and reliable transportation.

845. Subaru knew about the defect in the Affected Vehicles, allowing Subaru to cure their breach of warranty if it chose to do so.

846. Subaru's attempt to disclaim or limit the implied warranty of merchantability vis-à-vis consumers is unconscionable and unenforceable here. Specifically, Subaru's warranty limitations are unenforceable because they knowingly sold a defective product without informing consumers about the defect. The time limits contained in Subaru's warranty periods were also

unconscionable and inadequate to protect Plaintiff and other North Carolina Subclass members. Among other things, Plaintiff and other North Carolina Subclass members had no meaningful choice in determining these time limitations, the terms of which unreasonably favored Subaru. A gross disparity in bargaining power existed between Subaru and North Carolina Subclass members, and Subaru knew of the defect at the time of sale.

847. Plaintiff and North Carolina Subclass members have complied with all obligations under the warranty, or otherwise have been excused from performance of said obligations as a result of Subaru's conduct described herein. Affording Subaru a reasonable opportunity to cure the breach of written warranties therefore would be unnecessary and futile.

848. Subaru was provided notice of these issues by numerous complaints filed against it, internal investigations, postings on websites, and other sources.

849. As a direct and proximate result of Subaru's breach of the implied warranty of merchantability, Plaintiff and the Class have been damaged in an amount to be proven at trial.

O. Claims Brought on Behalf of the Oregon Subclass

COUNT XLII

**VIOLATIONS OF THE OREGON UNLAWFUL TRADE PRACTICES ACT
(OR. REV. STAT. § 646.605, *ET SEQ.*)
(As to all Defendants)**

850. Plaintiff Christensen ("Plaintiff," for purposes of all Oregon Subclass Counts) incorporates by reference all paragraphs as though fully set forth herein.

851. Plaintiff bring this Count on behalf of the Oregon Class members.

852. Defendants are each a "person" within the meaning of Or. Rev. Stat. § 646.650(4).

853. The Affected Vehicles at issue are "goods" obtained primarily for personal, family or household purposes within the meaning of Or. Rev. Stat. § 646.605(6).

854. Pursuant to the Oregon Unfair Trade Practices Act (“Oregon UTPA”) a person engages in an unlawful trade practice if in the course of the person’s business the person “(1) employs any unconscionable tactic in connection with selling, renting or disposing of ... goods or services.” Or. Rev. Stat. Ann. § 646.607(1). The Oregon UTPA prohibits a person from, in the course of the person’s business, doing any of the following: “(e) representing that goods... have...characteristics... uses, benefits ... or qualities that they do not have; (g) representing that ... goods are of a particular standard [or] quality ... if they are of another; (i) advertising ... goods or services with intent not to provide them as advertised;” and “(u) engaging in any other unfair or deceptive conduct in trade or commerce.” Or. Rev. Stat. § 646.608(1). Subaru participated in misleading, false, or deceptive acts that violated the Oregon UTPA. By concealing the known defects in Plaintiff’s Affected Vehicles Subaru engaged in deceptive business practices prohibited by the Oregon UTPA.

855. The facts concealed and omitted by Defendants were material in that a reasonable consumer would have considered them to be important in deciding whether to purchase or lease the Affected Vehicles or pay a lower price. Had Plaintiff and other Oregon Subclass members known of the Fuel Pump Defect, they would not have purchased or leased those vehicles, or would have paid substantially less for the vehicles than they did.

856. Defendants’ conduct proximately caused injuries to Plaintiff and the other Oregon Subclass members.

857. Plaintiff and the other Oregon Subclass members were injured and suffered ascertainable loss, injury in fact, and/or actual damage as a proximate result of Defendants’ conduct in that Plaintiff and the other Oregon Subclass members overpaid for their Affected Vehicles and did not receive the benefit of their bargain, and their Affected Vehicles have suffered

a diminution in value. These injuries are the direct and natural consequence of Defendants' misrepresentations, fraud, deceptive practices, and omissions.

858. Defendants' violations present a continuing risk to Plaintiff as well as to the general public. Defendants' unlawful acts and practices complained of herein affect the public interest.

859. Defendants' violations present a continuing risk to Plaintiff as well as to the general public. Subaru's unlawful acts and practices complained of herein affect the public interest.

860. Plaintiff is entitled to recover the greater of actual damages or \$200 pursuant to Or. Rev. Stat. § 646.638(1). Plaintiff and other Class members also seek to recover attorneys' fees, and any other just and proper relief available under the Oregon UTPA. Due to the significant level of reprehensibility, malice, reckless and outrageous indifference of Defendants' conduct, Plaintiff and the Class seek punitive damages.

COUNT XLIII

**BREACH OF IMPLIED WARRANTY OF MERCHANTABILITY
(OR. REV. STAT. § 72-3140)
(As to Subaru)**

862. Plaintiff incorporates by reference all paragraphs as though fully set forth herein.

863. Plaintiff bring this Count on behalf of the Oregon Class members.

864. Subaru is a merchant with respect to motor vehicles under Or. Rev. Stat. § 72-3140.

865. Under Or. Rev. Stat. § 72-3140, a warranty that the Affected Vehicles were in merchantable condition was implied by law in the transactions when Plaintiff and the Class purchased or leased their Affected Vehicles from Subaru.

866. The Affected Vehicles, when sold and at all times thereafter, were not merchantable and are not fit for the ordinary purpose for which cars are used.

867. Subaru marketed the Affected Vehicles as safe, reliable, and high quality automobiles that would function as reasonably expected by consumers and in accordance with industry standards. Such representations formed the basis of the bargain in Plaintiff's and Oregon Subclass members' decisions to purchase the Affected Vehicles.

868. Plaintiff and other Oregon Subclass members purchased the Affected Vehicles from Subaru, or through Subaru's authorized agents for retail sales. At all relevant times, Subaru was the manufacturer, distributor, warrantor, and/or seller of the Affected Vehicles.

869. Subaru knew or had reason to know of the specific use for which the Affected Vehicles were purchased.

870. Because of the Fuel Pump Defect, the Affected Vehicles were not in merchantable condition when sold and are not fit for the ordinary purpose of providing safe and reliable transportation.

871. Subaru knew about the defect in the Affected Vehicles, allowing Subaru to cure their breach of warranty if it chose to do so.

872. Subaru's attempt to disclaim or limit the implied warranty of merchantability vis-à-vis consumers is unconscionable and unenforceable here. Specifically, Subaru's warranty limitations are unenforceable because they knowingly sold a defective product without informing consumers about the defect. The time limits contained in Subaru's warranty periods were also unconscionable and inadequate to protect Plaintiff and other Oregon Subclass members. Among other things, Plaintiff and other Oregon Subclass members had no meaningful choice in determining these time limitations, the terms of which unreasonably favored Subaru. A gross disparity in bargaining power existed between Subaru and Oregon Subclass members, and Subaru knew of the defect at the time of sale.

873. Plaintiff and Oregon Subclass members have complied with all obligations under the warranty, or otherwise have been excused from performance of said obligations as a result of Subaru's conduct described herein. Affording Subaru a reasonable opportunity to cure the breach of written warranties therefore would be unnecessary and futile.

874. Subaru was provided notice of these issues by numerous complaints filed against it, internal investigations, postings on websites, and other sources.

875. As a direct and proximate result of Subaru's breach of the implied warranty of merchantability, Plaintiff and the Class have been damaged in an amount to be proven at trial.

876. P. Claims Brought on Behalf of the Pennsylvania Subclass

COUNT XLIV

**VIOLATIONS OF THE PENNSYLVANIA UNFAIR TRADE PRACTICES AND
CONSUMER PROTECTION LAW
(73 P.S. § 201-1 ET SEQ.)
(As to all Defendants)**

877. Plaintiff Lilley (“Plaintiff,” for purposes of all Pennsylvania Subclass Counts) incorporates by reference all paragraphs as though fully set forth herein.

878. Plaintiff brings this Count on behalf of the Pennsylvania Class members.

879. Plaintiff and other Class members purchased the Affected Vehicle primarily for personal, family or household purposes within the meaning of 73 P.S. § 201-9.2.

880. All of the acts complained of herein were perpetrated by Defendants in the course of trade or commerce within the meaning of 73 P.S. § 201-2(3).

881. The Pennsylvania Unfair Trade Practices and Consumer Protection Law (“Pennsylvania CPL”) prohibits unfair or deceptive acts or practices, including: (i) “Representing that goods and services have ... characteristics, ... [b]enefits or qualities that they do not have;” (ii) “Representing that goods or services are of a particular standard, quality or grade ... if they are of another;” (iii) “Advertising goods or services with intent not to see them as advertised;” and (iv) “Engaging in any other fraudulent or deceptive conduct which creates a likelihood of confusion or misunderstanding.” 73 P.S. § 201-2(4). Subaru engaged in unlawful trade practices, and unfair or deceptive acts or practices that violated Pennsylvania CPL.

882. Defendants knew or should have known that its conduct violated the Pennsylvania CPL.

883. In the course of its business, Defendants concealed and suppressed material facts concerning the Fuel Pump Defect. Defendants falsely represented the quality of the Affected Vehicles and omitted material facts regarding the fuel pump, as well as the durability and overall

value of the Affected Vehicles, for the purpose of inducing Plaintiff and other Pennsylvania Subclass members to purchase the Affected Vehicles, and to increase Defendants' revenue and profits.

884. The facts concealed and omitted by Defendants were material in that a reasonable consumer would have considered them to be important in deciding whether to purchase or lease the Affected Vehicles or pay a lower price. Had Plaintiff and other Pennsylvania Subclass members known of the Fuel Pump Defect, she would not have purchased or leased those vehicles, or would have paid substantially less for the vehicles than she did.

885. Plaintiff and the other Class members were injured and suffered ascertainable loss, injury in fact, and/or actual damages as a proximate result of Defendants' conduct in that Plaintiff and the other Class members overpaid for their Affected Vehicles and did not get the benefit of her bargain, and her Affected Vehicles have suffered a diminution in value. These injuries are the direct and natural consequence of Subaru's misrepresentations, fraud, deceptive practices, and omissions. Defendants' violations present a continuing risk to Plaintiff as well as to the general public. Defendants' unlawful acts and practices complained of herein affect the public interest.

886. Defendants are liable to Plaintiff and Pennsylvania Class members for treble her actual damages or \$100, whichever is greater, and attorneys' fees and costs. 73 P.S. § 201-9.2(a). Plaintiff and other Class members are also entitled to an award of punitive damages given that Defendants' conduct was malicious, wanton, willful, oppressive, or exhibited a reckless indifference to the rights of others.

COUNT XLV

**BREACH OF IMPLIED WARRANTY OF MERCHANTABILITY
(13 PA. CONS. STAT. ANN. § 2314)
(As to Subaru)**

887. Plaintiffs incorporate by reference all paragraphs as though fully set forth herein.

888. Plaintiffs bring this Count on behalf of the Pennsylvania Subclass members.

889. Subaru is a merchant with respect to motor vehicles under 13 Pa. Cons. Stat. Ann. § 2314.

890. Under 13 Pa. Cons. Stat. Ann. § 2314, a warranty that the Affected Vehicles were in merchantable condition was implied by law in the transactions when purchased or leased their Affected Vehicles from Subaru.

891. The Affected Vehicles, when sold and at all times thereafter, were not merchantable and are not fit for the ordinary purpose for which cars are used.

892. Subaru marketed the Affected Vehicles as safe, reliable, and high quality automobiles that would function as reasonably expected by consumers and in accordance with industry standards. Such representations formed the basis of the bargain in Plaintiffs' and Pennsylvania Subclass members' decisions to purchase the Affected Vehicles.

893. Plaintiffs and other Pennsylvania Subclass members purchased the Affected Vehicles from Subaru, or through Subaru's authorized agents for retail sales. At all relevant times, Subaru was the manufacturer, distributor, warrantor, and/or seller of the Affected Vehicles.

894. Subaru knew or had reason to know of the specific use for which the Affected Vehicles were purchased.

895. Because of the Fuel Pump Defect, the Affected Vehicles were not in merchantable condition when sold and are not fit for the ordinary purpose of providing safe and reliable transportation.

896. Subaru knew about the defect in the Affected Vehicles, allowing Subaru to cure their breach of warranty if it chose to do so.

897. Subaru's attempt to disclaim or limit the implied warranty of merchantability vis-à-vis consumers is unconscionable and unenforceable here. Specifically, Subaru's warranty limitations are unenforceable because they knowingly sold a defective product without informing consumers about the defect. The time limits contained in Subaru's warranty periods were also unconscionable and inadequate to protect Plaintiffs and other Pennsylvania Subclass members. Among other things, Plaintiffs and other Pennsylvania Subclass members had no meaningful choice in determining these time limitations, the terms of which unreasonably favored Subaru. A gross disparity in bargaining power existed between Subaru and Pennsylvania Subclass members, and Subaru knew of the defect at the time of sale.

898. Plaintiffs and Pennsylvania Subclass members have complied with all obligations under the warranty, or otherwise have been excused from performance of said obligations as a result of Subaru's conduct described herein. Affording Subaru a reasonable opportunity to cure the breach of written warranties therefore would be unnecessary and futile.

899. Subaru was provided notice of these issues by numerous complaints filed against it, internal investigations, postings on websites, and other sources.

900. As a direct and proximate result of Subaru's breach of the implied warranty of merchantability, Plaintiffs and the Class have been damaged in an amount to be proven at trial.

Q. Claims Brought on Behalf of the Rhode Island Subclass

COUNT XLVI

**VIOLATION OF THE RHODE ISLAND UNFAIR TRADE PRACTICES
AND CONSUMER PROTECTION ACT
(R.I. GEN. LAWS § 6-13.1 ET SEQ.)
(As to all Defendants)**

901. Plaintiff Biondo ("Plaintiff," for purposes of the next three counts) incorporates by reference all paragraphs as though full set forth herein.

902. Plaintiff brings this Count on behalf of the Rhode Island Subclass members.

903. Unfair methods of competition and unfair or deceptive acts or practices in the conduct of trade or commerce are unlawful. R.I. Gen. Laws § 6-13.1-2.

904. Rhode Island's Unfair Trade Practices and Consumer Protections Act ("Rhode Island CPA") prohibits "unfair or deceptive acts or practices in the conduct of any trade or commerce" including: "(v) Representing that goods or services have sponsorship, approval, characteristics, ingredients, uses, benefits, or quantities that they do not have;" "(vii) Representing that goods or services are of a particular standard, quality, or grade, ... if they are of another;" "(ix) Advertising goods or services with intent not to sell them as advertised;" "(xii) Engaging in any other conduct that similarly creates a likelihood of confusion or of misunderstanding;" "(xiii) Engaging in any act or practice that is unfair or deceptive to the consumer;" and "(xiv) Using other methods, acts or practices which mislead or deceive Members of the public in a material respect." R.I. Gen. Law § 6-13.1-1(6).

905. Defendants engaged in unlawful trade practices, including: (1) representing that the Affected Vehicles have characteristics, uses, benefits, and qualities which they do not have; (2) representing that the Affected Vehicles are of a particular standard and quality when they are not; (3) advertising the Affected Vehicles with the intent to sell them as advertised; and (4) otherwise engaging in conduct that is unfair or deceptive and likely to deceive. Subaru's conduct violated the Rhode Island CPA and Subaru knew or should have known that its conduct would be in violation thereof.

906. The facts concealed and omitted by Subaru were material in that a reasonable consumer would have considered them to be important in deciding whether to purchase or lease the Affected Vehicles or pay a lower price. Had Plaintiff and other Rhode Island Subclass members

known of the Fuel Pump Defect, they would not have purchased or leased those vehicles, or would have paid substantially less for the vehicles than they did.

907. Defendants' conduct proximately caused injuries to Plaintiff and the other Rhode Island Subclass members.

908. Plaintiff and the other Rhode Island Subclass members were injured and suffered ascertainable loss, injury in fact, and/or actual damage as a proximate result of Defendants' conduct in that Plaintiff and the other Rhode Island Subclass members overpaid for their Affected Vehicles and did not receive the benefit of their bargain, and their Affected Vehicles have suffered a diminution in value. These injuries are the direct and natural consequence of Subaru's misrepresentations, fraud, deceptive practices, and omissions.

909. Defendants' violations present a continuing risk to Plaintiff as well as to the general public. Defendants' unlawful acts and practices complained of herein affect the public interest.

910. Plaintiff and the Class members are entitled to recover the greater of actual damages or \$200 pursuant to R.I. Gen. Laws § 6-13.1-5.2(a). Plaintiff and the Class also seek punitive damages in the discretion of the Court.

COUNT XLVII

BREACH OF IMPLIED WARRANTY OF MERCHANTABILITY (R.I. GEN. LAWS § 6A-2-314) (As to Subaru)

911. Plaintiff incorporates by reference all paragraphs as though fully set forth herein.

912. Plaintiff bring this Count on behalf of the Rhode Island Subclass members.

913. Subaru is a merchant with respect to motor vehicles under R.I. Gen. Laws § 6A-2-314.

914. Under R.I. Gen. Laws § 6A-2-314, a warranty that the Affected Vehicles were in merchantable condition was implied by law in the transactions when Plaintiff and Class members purchased or leased their Affected Vehicles from Subaru.

915. The Affected Vehicles, when sold and at all times thereafter, were not merchantable and are not fit for the ordinary purpose for which cars are used.

916. Subaru marketed the Affected Vehicles as safe, reliable, and high quality automobiles that would function as reasonably expected by consumers and in accordance with industry standards. Such representations formed the basis of the bargain in Plaintiff's and Rhode Island Subclass members' decisions to purchase the Affected Vehicles.

917. Plaintiff and other Rhode Island Subclass members purchased the Affected Vehicles from Subaru, or through Subaru's authorized agents for retail sales. At all relevant times, Subaru was the manufacturer, distributor, warrantor, and/or seller of the Affected Vehicles.

918. Subaru knew or had reason to know of the specific use for which the Affected Vehicles were purchased.

919. Because of the Fuel Pump Defect, the Affected Vehicles were not in merchantable condition when sold and are not fit for the ordinary purpose of providing safe and reliable transportation.

920. Subaru knew about the defect in the Affected Vehicles, allowing Subaru to cure their breach of warranty if it chose to do so.

921. Subaru's attempt to disclaim or limit the implied warranty of merchantability vis-à-vis consumers is unconscionable and unenforceable here. Specifically, Subaru's warranty limitations are unenforceable because they knowingly sold a defective product without informing consumers about the defect. The time limits contained in Subaru's warranty periods were also

unconscionable and inadequate to protect Plaintiff and other Rhode Island Subclass members. Among other things, Plaintiff and other Rhode Island Subclass members had no meaningful choice in determining these time limitations, the terms of which unreasonably favored Subaru. A gross disparity in bargaining power existed between Subaru and Rhode Island Subclass members, and Subaru knew of the defect at the time of sale.

922. Plaintiff and Rhode Island Subclass members have complied with all obligations under the warranty, or otherwise have been excused from performance of said obligations as a result of Subaru's conduct described herein. Affording Subaru a reasonable opportunity to cure the breach of written warranties therefore would be unnecessary and futile.

923. Subaru was provided notice of these issues by numerous complaints filed against it, internal investigations, postings on websites, and other sources.

924. As a direct and proximate result of Subaru's breach of the implied warranty of merchantability, Plaintiff and the Class have been damaged in an amount to be proven at trial.

R. Claims Brought on Behalf of the South Carolina Subclass

COUNT XLVIII

**VIOLATIONS OF THE SOUTH CAROLINA UNFAIR AND DECEPTIVE
TRADE PRACTICES ACT**

(S.C. CODE ANN. § 39-10 *ET SEQ.*)

(As to all Defendants)

925. Plaintiff Christine Schultz (for purposes of the next two counts, "Plaintiff") incorporates by reference all paragraphs though fully set forth herein.

926. Plaintiff brings this Count on behalf of the South Carolina Subclass members.

927. The South Carolina Unfair Trade Practices Act (S.C.U.T.P.A) makes unlawful all "unfair or deceptive acts or practices in or affecting commerce." S.C. Code Ann. § 39-20.

928. Defendants are each persons and engaged in trade or commerce when marketing, selling and servicing the Affected Vehicles for the purposes of the S.C.U.T.P.A. S.C. Code Ann. § 39-5-10(a).

929. Defendants engaged in unfair and deceptive practices through the course of its representations and omissions relating to Affected Vehicles and its conduct of its recall, as alleged above.

930. The facts concealed and omitted by Defendants were material in that a reasonable consumer would have considered them to be important in deciding whether to purchase or lease the Affected Vehicles or pay a lower price. Had Plaintiff and other South Carolina Subclass members known of the Fuel Pump Defect, they would not have purchased or leased those vehicles, or would have paid substantially less for the vehicles than they did.

931. Defendants' conduct proximately caused injuries to Plaintiff and the other South Carolina Subclass members.

932. Plaintiff and the other North Carolina Subclass members were injured and suffered ascertainable loss, injury in fact, and/or actual damage as a proximate result of Defendants' conduct in that Plaintiff and the other South Carolina Subclass members overpaid for their Affected Vehicles and did not receive the benefit of their bargain, and their Affected Vehicles have suffered a diminution in value. These injuries are the direct and natural consequence of Defendants' misrepresentations, fraud, deceptive practices, and omissions.

933. Defendants' violations present a continuing risk to Plaintiff as well as to the general public. Defendants' unlawful acts and practices complained of herein affect the public interest.

934. Plaintiff and the Class seek monetary relief against Subaru in an amount to be determined at trial. Plaintiff and the Class also seek treble damages because all or part of

Defendants' unfair and deceptive acts were done willfully or knowingly. Indeed, Defendants carried out despicable conduct with willful and conscious disregard of the rights of others. Defendants' unlawful conduct constitutes malice, oppression, and fraud warranting punitive damages.

935. Plaintiff also seeks treble damages, attorneys' fees, and such other relief as is just and proper. S.C. Gen. Code Ann. § 39-4-140.

COUNT XLIX

BREACH OF THE IMPLIED WARRANTY OF MERCHANTABILITY (S.C. GEN. CODE ANN. § 36-2-314) (As to Subaru)

936. Plaintiff incorporates by reference all paragraphs as though fully set forth herein.

937. Plaintiff brings this Count on behalf of the South Carolina Class members.

938. Subaru is a merchant with respect to motor vehicles within the meaning of the S.C. Gen. Code Ann. § 36-2-314.

939. Under S.C. Gen. Code Ann. § 36-2-314, a warranty that the Affected Vehicles were in merchantable condition was implied by law in the transactions when Plaintiff and the Class purchased or leased their Affected Vehicles from Subaru.

940. The Affected Vehicles, when sold and at all times thereafter, were not merchantable and are not fit for the ordinary purpose for which cars are used.

941. Subaru marketed the Affected Vehicles as safe, reliable, and high quality automobiles that would function as reasonably expected by consumers and in accordance with industry standards. Such representations formed the basis of the bargain in Plaintiff's and South Carolina Subclass members' decisions to purchase the Affected Vehicles.

942. Plaintiff and other South Carolina Subclass members purchased the Affected Vehicles from Subaru, or through Subaru's authorized agents for retail sales. At all relevant times, Subaru was the manufacturer, distributor, warrantor, and/or seller of the Affected Vehicles.

943. Subaru knew or had reason to know of the specific use for which the Affected Vehicles were purchased.

944. Because of the Fuel Pump Defect, the Affected Vehicles were not in merchantable condition when sold and are not fit for the ordinary purpose of providing safe and reliable transportation.

945. Subaru knew about the defect in the Affected Vehicles, allowing Subaru to cure their breach of warranty if it chose to do so.

946. Subaru's attempt to disclaim or limit the implied warranty of merchantability vis-à-vis consumers is unconscionable and unenforceable here. Specifically, Subaru's warranty limitations are unenforceable because they knowingly sold a defective product without informing consumers about the defect. The time limits contained in Subaru's warranty periods were also unconscionable and inadequate to protect Plaintiff and other South Carolina Subclass members. Among other things, Plaintiff and other South Carolina Subclass members had no meaningful choice in determining these time limitations, the terms of which unreasonably favored Subaru. A gross disparity in bargaining power existed between Subaru and South Carolina Subclass members, and Subaru knew of the defect at the time of sale.

947. Plaintiff and South Carolina Subclass members have complied with all obligations under the warranty, or otherwise have been excused from performance of said obligations as a result of Subaru's conduct described herein. Affording Subaru a reasonable opportunity to cure the breach of written warranties therefore would be unnecessary and futile.

948. Subaru was provided notice of these issues by numerous complaints filed against it, internal investigations, postings on websites, and other sources.

949. As a direct and proximate result of Subaru's breach of the implied warranty of merchantability, Plaintiff and the Class have been damaged in an amount to be proven at trial.

S. Claims Brought on Behalf of the Tennessee Subclass

COUNT L

**VIOLATIONS OF THE TENNESSEE CONSUMER PROTECTION ACT
(TEN. CODE ANN. § 47-18-101 *ET SEQ.*)
(As to all Defendants)**

950. Plaintiff Cole Sweeton (for purposes of the next two counts, "Plaintiff") incorporates by reference all paragraphs though fully set forth herein.

951. Plaintiff brings this Count on behalf of the Tennessee Subclass members.

952. Defendants, Plaintiff, and other Class Members are "consumers" and "persons" within the meaning of the Tennessee Consumer Protection Act ("Tennessee CPA"), Ten. Code Ann. § 47-18-103(3), (14).

953. The Affected Vehicles are "goods" within the meaning of Ten. Code Ann. § 47-18-103(8).

954. The Tennessee CPA declares that "[u]nfair or deceptive acts or practices affecting the conduct of any trade or commerce constitute unlawful acts or practices" and prohibits such conduct as "[r]epresenting that goods or services have sponsorship, approval, characteristics, ingredients, uses, benefits or quantities that they do not have" or "that goods or services are of a particular standard, quality or grade, or that goods are of a particular style or model, if they are of another." Ten. Code Ann. § 47-18-104(a), (b)(5), (7).

955. The facts concealed and omitted by Defendants were material in that a reasonable consumer would have considered them to be important in deciding whether to purchase or lease

the Affected Vehicles or pay a lower price. Had Plaintiff and other Tennessee Subclass members known of the Fuel Pump Defect, they would not have purchased or leased those vehicles, or would have paid substantially less for the vehicles than they did.

956. Defendants' conduct proximately caused injuries to Plaintiff and the other Tennessee Subclass members.

957. Plaintiff and the other Tennessee Subclass members were injured and suffered ascertainable loss, injury in fact, and/or actual damage as a proximate result of Defendants' conduct in that Plaintiff and the other Tennessee Subclass members overpaid for their Affected Vehicles and did not receive the benefit of their bargain, and their Affected Vehicles have suffered a diminution in value. These injuries are the direct and natural consequence of Defendants' misrepresentations, fraud, deceptive practices, and omissions.

958. Defendants' violations present a continuing risk to Plaintiff as well as to the general public. Defendants' unlawful acts and practices complained of herein affect the public interest.

959. Plaintiff and the Class seek monetary relief against Defendants in an amount to be determined at trial. Plaintiff and the Class also seek treble damages because all or part of Defendants' unfair and deceptive acts were done willfully or knowingly. Indeed, Defendants carried out despicable conduct with willful and conscious disregard of the rights of others. Defendants' unlawful conduct constitutes malice, oppression, and fraud warranting punitive damages.

960. Plaintiff also seeks injunctive and declaratory relief, attorneys' fees and any other just and proper relief available.

COUNT LI

**BREACH OF THE IMPLIED WARRANTY OF MERCHANTABILITY
(TEN. CODE ANN. § 47-2-314)
(As to Subaru)**

961. Plaintiff incorporates by reference all paragraphs as though fully set forth herein.

962. Plaintiff bring this Count on behalf of the Tennessee Class members.

963. Subaru is a merchant with respect to motor vehicles within the meaning of the Ten. Code Ann. § 47-2-314.

964. Under Ten. Code Ann. § 47-2-314, a warranty that the Affected Vehicles were in merchantable condition was implied by law in the transactions when Plaintiff and the Class purchased or leased their Affected Vehicles from Subaru.

965. The Affected Vehicles, when sold and at all times thereafter, were not merchantable and are not fit for the ordinary purpose for which cars are used.

966. Subaru marketed the Affected Vehicles as safe, reliable, and high quality automobiles that would function as reasonably expected by consumers and in accordance with industry standards. Such representations formed the basis of the bargain in Plaintiff's and Tennessee Subclass members' decisions to purchase the Affected Vehicles.

967. Plaintiff and other Tennessee Subclass members purchased the Affected Vehicles from Subaru, or through Subaru's authorized agents for retail sales. At all relevant times, Subaru was the manufacturer, distributor, warrantor, and/or seller of the Affected Vehicles.

968. Subaru knew or had reason to know of the specific use for which the Affected Vehicles were purchased.

969. Because of the Fuel Pump Defect, the Affected Vehicles were not in merchantable condition when sold and are not fit for the ordinary purpose of providing safe and reliable transportation.

970. Subaru knew about the defect in the Affected Vehicles, allowing Subaru to cure their breach of warranty if it chose to do so.

971. Subaru's attempt to disclaim or limit the implied warranty of merchantability vis-à-vis consumers is unconscionable and unenforceable here. Specifically, Subaru's warranty limitations are unenforceable because they knowingly sold a defective product without informing consumers about the defect. The time limits contained in Subaru's warranty periods were also unconscionable and inadequate to protect Plaintiff and other Tennessee Subclass members. Among other things, Plaintiff and other Tennessee Subclass members had no meaningful choice in determining these time limitations, the terms of which unreasonably favored Subaru. A gross disparity in bargaining power existed between Subaru and Tennessee Subclass members, and Subaru knew of the defect at the time of sale.

972. Plaintiff and Tennessee Subclass members have complied with all obligations under the warranty, or otherwise have been excused from performance of said obligations as a result of Subaru's conduct described herein. Affording Subaru a reasonable opportunity to cure the breach of written warranties therefore would be unnecessary and futile.

973. Subaru was provided notice of these issues by numerous complaints filed against it, internal investigations, postings on websites, and other sources.

974. As a direct and proximate result of Subaru's breach of the implied warranty of merchantability, Plaintiff and the Class have been damaged in an amount to be proven at trial.

T. Claims Brought on Behalf of the Texas Subclass

COUNT LII

**VIOLATIONS OF THE TEXAS DECEPTIVE TRADE PRACTICES-CONSUMER
PROTECTION ACT (“DTPA”)
(TEX. BUS. & COM. CODE §§ 17.41, ET SEQ.)
(As to all Defendants)**

975. Plaintiffs Nelson and Gardener (“Plaintiffs,” for purposes of the next three counts) incorporates by reference all paragraphs as though fully set forth herein.

976. Plaintiffs assert this Count individually and on behalf of the Texas Subclass.

977. Plaintiffs assert a claim under the Texas Deceptive Trade Practices-Consumer Protection Act (“DTPA”), which makes it unlawful to commit “[f]alse, misleading, or deceptive acts or practices in the conduct of any trade or commerce.” Tex. Bus. & Com. Code § 17.46.

978. Plaintiffs and Class members are “consumers” within the meaning of Tex. Bus. & Com. Code § 17.46(4).

979. Defendants engaged in “trade or commerce” within the meaning of the DTPA.

980. The DTPA prohibits “false, misleading, or deceptive acts or services in the conduct of any trade or commerce[.]” Tex. Bus. & Com. Code § 17.46(a). By its acts, omissions, failures, and conduct described in this Complaint, Defendants have violated Tex. Bus. & Com. Code § 17.46(b)(1), (2), (5), (7), (9), (12) (13), (20), and (24). Defendants participated in unfair and deceptive trade practices that violated the DTPA as described herein.

981. The facts concealed and omitted by Defendants were material in that a reasonable consumer would have considered them to be important in deciding whether to purchase or lease the Affected Vehicles or pay a lower price. Had Plaintiffs and other Texas Subclass members known of the Fuel Pump Defect, they would not have purchased or leased those vehicles, or would have paid substantially less for the vehicles than they did.

982. Defendants' conduct proximately caused injuries to Plaintiffs and the other Texas Subclass members.

983. Plaintiffs and the other Texas Subclass members were injured and suffered ascertainable loss, injury in fact, and/or actual damage as a proximate result of Subaru's conduct in that Plaintiff and the other Texas Subclass members overpaid for their Affected Vehicles and did not receive the benefit of their bargain, and their Affected Vehicles have suffered a diminution in value. These injuries are the direct and natural consequence of Subaru's misrepresentations, fraud, deceptive practices, and omissions.

984. Defendants' violations present a continuing risk to Plaintiffs as well as to the general public. Subaru's unlawful acts and practices complained of herein affect the public interest.

985. Plaintiff and Class members seek monetary relief against Subaru pursuant to Tex. Bus. & Com. Code §§ 14.41, et seq. Plaintiff also seeks an order enjoining Subaru's unfair, unlawful, and/or deceptive practices, attorneys' fees, and mental anguish damages and additional damages up to three times the amount of economic damages as permitted by the DTPA.

COUNT LIII

BREACH OF IMPLIED WARRANTY OF MERCHANTABILITY, (TEX. BUS. & COM. CODE §§ 2.314 AND 2A.212) (As to Subaru)

986. Plaintiffs incorporate by reference all paragraphs t as though fully set forth herein.

987. Plaintiffs bring this Count individually and on behalf of the Texas Subclass against Subaru.

988. Subaru was at all times a "merchant" with respect to motor vehicles under Tex. Bus. & Com. Code § 2.104(1) and 2A.103(a)(2), and "seller" of motor vehicles under § 2.103(a)(4). With respect to leases, Subaru is and was at all relevant times a "lessor" of motor vehicles under Tex. Bus. & Com. Code § 2A.103(a)(16).

989. The Affected Vehicles are and were at all relevant times “goods” within the meaning of Tex. Bus. & Com. Code. §§ 2.105(a) and 2A.103(a)(16).

990. A warranty that the Affected Vehicles were in merchantable condition and fit for the ordinary purpose for which the vehicles are used is implied by law, pursuant to Tex. Bus. & Com. Code §§ 2.314 and 2A.212.

991. The Affected Vehicles, when sold and at all times thereafter, were not merchantable and are not fit for the ordinary purpose for which cars are used.

992. Subaru marketed the Affected Vehicles as safe, reliable, and high quality automobiles that would function as reasonably expected by consumers and in accordance with industry standards. Such representations formed the basis of the bargain in Plaintiffs’ and Texas Subclass members’ decisions to purchase the Affected Vehicles.

993. Plaintiffs and other Texas Subclass members purchased the Affected Vehicles from Subaru, or through Subaru’s authorized agents for retail sales. At all relevant times, Subaru was the manufacturer, distributor, warrantor, and/or seller of the Affected Vehicles.

994. Subaru knew or had reason to know of the specific use for which the Affected Vehicles were purchased.

995. Because of the Fuel Pump Defect, the Affected Vehicles were not in merchantable condition when sold and are not fit for the ordinary purpose of providing safe and reliable transportation.

996. Subaru knew about the defect in the Affected Vehicles, allowing Subaru to cure their breach of warranty if it chose to do so.

997. Subaru’s attempt to disclaim or limit the implied warranty of merchantability vis-à-vis consumers is unconscionable and unenforceable here. Specifically, Subaru’s warranty

limitations are unenforceable because they knowingly sold a defective product without informing consumers about the defect. The time limits contained in Subaru's warranty periods were also unconscionable and inadequate to protect Plaintiffs and other Texas Subclass members. Among other things, Plaintiffs and other Texas Subclass members had no meaningful choice in determining these time limitations, the terms of which unreasonably favored Subaru. A gross disparity in bargaining power existed between Subaru and Texas Subclass members, and Subaru knew of the defect at the time of sale.

998. Plaintiffs and Texas Subclass members have complied with all obligations under the warranty, or otherwise have been excused from performance of said obligations as a result of Subaru's conduct described herein. Affording Subaru a reasonable opportunity to cure the breach of written warranties therefore would be unnecessary and futile.

999. Subaru was provided notice of these issues by numerous complaints filed against it, internal investigations, postings on websites, and other sources.

1000. As a direct and proximate result of Subaru's breach of the implied warranty of merchantability, Plaintiffs and the Class have been damaged in an amount to be proven at trial.

U. Claims Brought on Behalf of the Vermont Subclass

COUNT LIV

**VIOLATION OF VERMONT CONSUMER FRAUD ACT
(VT. STAT. ANN. TIT. 9, § 2451 *ET SEQ.*)
(As to all Defendants)**

1001. Plaintiff Benjamin Moore ("Plaintiff," for purposes of the next two counts) incorporates by reference all paragraphs as though fully set forth herein.

1002. Plaintiff brings this Count on behalf of the Vermont Subclass members.

1003. Defendants are each a seller within the meaning of Vt. Stat. Ann. tit. 9, § 2451(a)(c).

1004. The Vermont Consumer Fraud Act (“Vermont CFA”) makes unlawful “[u]nfair methods of competition in commerce, and unfair or deceptive acts or practices in commerce.” Vt. Stat. Ann. tit. 9, § 2453(a).

1005. The facts concealed and omitted by Defendants were material in that a reasonable consumer would have considered them to be important in deciding whether to purchase or lease the Affected Vehicles or pay a lower price. Had Plaintiff and other Vermont Subclass members known of the Fuel Pump Defect, they would not have purchased or leased those vehicles, or would have paid substantially less for the vehicles than they did.

1006. Defendants’ conduct proximately caused injuries to Plaintiff and the other Vermont Subclass members.

1007. Plaintiff and the other Vermont Subclass members were injured and suffered ascertainable loss, injury in fact, and/or actual damage as a proximate result of Defendants’ conduct in that Plaintiff and the other Vermont Subclass members overpaid for their Affected Vehicles and did not receive the benefit of their bargain, and their Affected Vehicles have suffered a diminution in value. These injuries are the direct and natural consequence of Defendants’ misrepresentations, fraud, deceptive practices, and omissions.

1008. Defendants’ violations present a continuing risk to Plaintiff as well as to the general public. Defendants’ unlawful acts and practices complained of herein affect the public interest.

1009. Defendants’ conduct proximately caused injuries to Plaintiff and the other Class members.

1010. Plaintiff and the other Class members were injured and suffered ascertainable loss, injury in fact, and/or actual damages as a proximate result of Defendants’ conduct in that Plaintiff and the other Class members overpaid for their Affected Vehicles and did not get the benefit of

their bargain, and their Affected Vehicles have suffered a diminution in value. These injuries are the direct and natural consequence of Defendants' misrepresentations and omissions.

1011. Defendants' violations present a continuing risk to Plaintiff and Class members as well as to the general public. Subaru's unlawful acts and practices complained of herein affect the public interest. Specifically: (1) the number of consumers affected by Subaru's deceptive practices are in the hundreds of thousands nation-wide; (2) Defendants have significantly high sophistication and bargaining power with respect to the manufacture and sale of the Affected Vehicles to Plaintiff and individual Class members; and (3) so long as the Affected Vehicles continued to be sold and distributed for use with American diesel fuel, the likelihood of continued impact on other consumers is significant.

1012. Plaintiff and Class members are entitled to recover "appropriate equitable relief" and "the amount of [their] damages, or the consideration or the value of the consideration given by [them], reasonable attorney's fees, and exemplary damages not exceeding three times the value of the consideration given by [them]" pursuant to Vt. Stat. Ann. tit. 9, § 2461(b).

COUNT LV

BREACH OF IMPLIED WARRANTY OF MERCHANTABILITY (VT. STAT. ANN. TIT. 9A § 2-314 (As to Subaru)

1013. Plaintiff incorporates by reference all paragraphs as though fully set forth herein.

1014. Plaintiff brings this Count on behalf of the Vermont Class members.

1015. Subaru is a merchant with respect to motor vehicles under Vt. Stat. Ann. tit. 9A § 2-104.

1016. Under Vt. Stat. Ann. tit. 9A § 2-314, a warranty that the Affected Vehicles were in merchantable condition was implied by law in the transactions when Plaintiff and Class members purchased or leased their Affected Vehicles from Subaru.

1017. The Affected Vehicles, when sold and at all times thereafter, were not merchantable and are not fit for the ordinary purpose for which cars are used.

1018. Subaru marketed the Affected Vehicles as safe, reliable, and high quality automobiles that would function as reasonably expected by consumers and in accordance with industry standards. Such representations formed the basis of the bargain in Plaintiff's and Vermont Subclass members' decisions to purchase the Affected Vehicles.

1019. Plaintiff and other Vermont Subclass members purchased the Affected Vehicles from Subaru, or through Subaru's authorized agents for retail sales. At all relevant times, Subaru was the manufacturer, distributor, warrantor, and/or seller of the Affected Vehicles.

1020. Subaru knew or had reason to know of the specific use for which the Affected Vehicles were purchased.

1021. Because of the Fuel Pump Defect, the Affected Vehicles were not in merchantable condition when sold and are not fit for the ordinary purpose of providing safe and reliable transportation.

1022. Subaru knew about the defect in the Affected Vehicles, allowing Subaru to cure their breach of warranty if it chose to do so.

1023. Subaru's attempt to disclaim or limit the implied warranty of merchantability vis-à-vis consumers is unconscionable and unenforceable here. Specifically, Subaru's warranty limitations are unenforceable because they knowingly sold a defective product without informing consumers about the defect. The time limits contained in Subaru's warranty periods were also unconscionable and inadequate to protect Plaintiff and other Vermont Subclass members. Among other things, Plaintiff and other Vermont Subclass members had no meaningful choice in determining these time limitations, the terms of which unreasonably favored Subaru. A gross

disparity in bargaining power existed between Subaru and Vermont Subclass members, and Subaru knew of the defect at the time of sale.

1024. Plaintiff and Vermont Subclass members have complied with all obligations under the warranty, or otherwise have been excused from performance of said obligations as a result of Subaru's conduct described herein. Affording Subaru a reasonable opportunity to cure the breach of written warranties therefore would be unnecessary and futile.

1025. Subaru was provided notice of these issues by numerous complaints filed against it, internal investigations, postings on websites, and other sources.

1026. As a direct and proximate result of Subaru's breach of the implied warranty of merchantability, Plaintiff and the Class have been damaged in an amount to be proven at trial.

1027. As a direct and proximate result of Subaru's breach of the implied warranty of merchantability, Plaintiff have been damaged in an amount to be proven at trial.

V. Claims Brought on Behalf of the Washington Subclass

COUNT LVII

**VIOLATION OF THE WASHINGTON CONSUMER PROTECTION ACT
(WASH. REV. CODE ANN. § 19.86.010 *ET SEQ.*)
(As to all Defendants)**

1028. Plaintiffs Brockman and Brown ("Plaintiffs," for purposes of the next two counts) incorporates by reference all paragraphs as though fully set forth herein.

1029. Plaintiffs bring this Count on behalf of the Washington Subclass members.

1030. Defendants, Plaintiffs and other Class members are a "person" under Wash. Rev. Code Ann. § 19.86.010(1). ("Washington CPA").

1031. Defendants engaged in "trade" or "commerce" under Wash. Rev. Code Ann. § 19.86.010(2).

1032. The Washington Consumer Protection Act (“Washington CPA”) broadly prohibits “[u]nfair methods of competition and unfair or deceptive acts or practices in the conduct of any trade or commerce.” Wash. Rev. Code Ann. § 19.86.020. Defendants’ conduct was unfair because it (1) offends public policy as it has been established by statutes, the common law, or otherwise; (2) is immoral, unethical, oppressive, or unscrupulous; or (3) causes substantial injury to consumers. Defendants’ conduct is deceptive because it has the capacity or tendency to deceive.

1033. In the course of its business, Defendants concealed and suppressed material facts concerning the Fuel Pump Defect. Defendants falsely represented the quality of the Affected Vehicles and omitted material facts regarding the fuel pump, as well as the durability and overall value of the Affected Vehicles, for the purpose of inducing Plaintiffs and other Washington Subclass members to purchase the Affected Vehicles, and to increase Defendants’ revenue and profits.

1034. The facts concealed and omitted by Defendants were material in that a reasonable consumer would have considered them to be important in deciding whether to purchase or lease the Affected Vehicles or pay a lower price. Had Plaintiffs and other Washington Subclass members known of the Fuel Pump Defect, they would not have purchased or leased those vehicles, or would have paid substantially less for the vehicles than they did.

1035. Plaintiffs and the other Class members were injured and suffered ascertainable loss, injury in fact, and/or actual damages as a proximate result of Defendants’ conduct in that Plaintiffs and the other Class members overpaid for their Affected Vehicles and did not get the benefit of their bargain, and their Affected Vehicles have suffered a diminution in value. These injuries are the direct and natural consequence of Subaru’s misrepresentations, fraud, deceptive practices, and omissions. Defendants’ violations present a continuing risk to Plaintiffs as well as to the general

public. Defendants' unlawful acts and practices complained of herein impact the public interest. Specifically: (1) the number of consumers affected by Defendants' deceptive practices are in the hundreds of thousands nation-wide; (2) Defendants have significantly high sophistication and bargaining power with respect to the manufacture and sale of the Affected Vehicles to Plaintiffs and individual Class Members; and (3) so long as the Affected Vehicles continued to be sold and distributed for use with American diesel fuel, the likelihood of continued impact on other consumers is significant.

1036. Defendants are liable to Plaintiffs and other Class members for damages in amounts to be proven at trial, including attorneys' fees, costs, and treble damages up to \$25,000, as well as any other just and proper relief the Court may deem appropriate under Wash. Rev. Code Ann. § 19.86.090.

COUNT LVIII

BREACH OF IMPLIED WARRANTY OF MERCHANTABILITY (WASH. REV. CODE ANN. § 62A.2-314) (As to Subaru)

1037. Plaintiffs incorporate by reference all paragraphs as though fully set forth herein.

1038. Plaintiffs bring this Count on behalf of the Washington Subclass members.

1039. Under Wash. Rev. Code Ann. § 62A.2-314, a warranty that the Affected Vehicles were in merchantable condition as implied by law in the transactions when Plaintiffs purchased or leased their Affected Vehicles from Subaru.

1040. The Affected Vehicles, when sold and at all times thereafter, were not merchantable and are not fit for the ordinary purpose for which cars are used.

1041. Subaru marketed the Affected Vehicles as safe, reliable, and high quality automobiles that would function as reasonably expected by consumers and in accordance with

industry standards. Such representations formed the basis of the bargain in Plaintiffs' and Washington Subclass members' decisions to purchase the Affected Vehicles.

1042. Plaintiffs and other Washington Subclass members purchased the Affected Vehicles from Subaru, or through Subaru's authorized agents for retail sales. At all relevant times, Subaru was the manufacturer, distributor, warrantor, and/or seller of the Affected Vehicles.

1043. Subaru knew or had reason to know of the specific use for which the Affected Vehicles were purchased.

1044. Because of the Fuel Pump Defect, the Affected Vehicles were not in merchantable condition when sold and are not fit for the ordinary purpose of providing safe and reliable transportation.

1045. Subaru knew about the defect in the Affected Vehicles, allowing Subaru to cure their breach of warranty if it chose to do so.

1046. Subaru's attempt to disclaim or limit the implied warranty of merchantability vis-à-vis consumers is unconscionable and unenforceable here. Specifically, Subaru's warranty limitations are unenforceable because they knowingly sold a defective product without informing consumers about the defect. The time limits contained in Subaru's warranty periods were also unconscionable and inadequate to protect Plaintiffs and other Washington Subclass members. Among other things, Plaintiffs and other Washington Subclass members had no meaningful choice in determining these time limitations, the terms of which unreasonably favored Subaru. A gross disparity in bargaining power existed between Subaru and Washington Subclass members, and Subaru knew of the defect at the time of sale.

1047. Plaintiffs and Washington Subclass members have complied with all obligations under the warranty, or otherwise have been excused from performance of said obligations as a

result of Subaru's conduct described herein. Affording Subaru a reasonable opportunity to cure the breach of written warranties therefore would be unnecessary and futile.

1048. Subaru was provided notice of these issues by numerous complaints filed against it, internal investigations, postings on websites, and other sources.

1049. As a direct and proximate result of Subaru's breach of the implied warranty of merchantability, Plaintiffs and the Class have been damaged in an amount to be proven at trial.

W. Claims Brought on Behalf of the Wisconsin Subclass

COUNT LIX

**VIOLATIONS OF THE WISCONSIN
DECEPTIVE TRADE PRACTICES ACT
(WIS. STAT. § 110.18)
(As to all Defendants)**

1050. Plaintiffs Christine King and Kevin King ("Plaintiffs," for purposes of this count) incorporate by reference all paragraphs as though fully set forth herein.

1051. Plaintiffs bring this Count on behalf of the Wisconsin Subclass members.

1052. Defendants are a "person, firm, corporation or association" within the meaning of Wis. Stat. § 100.18(1).

1053. Plaintiffs and other Class members are members of "the public" within the meaning of the Wis. Stat. § 100.18(1). Plaintiffs and other Class Members purchased or leased one or more Affected Vehicles.

1054. The Wisconsin Deceptive Practices Act ("Wisconsin DTPA") prohibits an "assertion, representation or statement of facts which is untrue, deceptive, or misleading." Wis. Stat. § 100.18(1). By systematically concealing the defects in the Affected Vehicles, Subaru's conduct, acts, and practices violated the Wisconsin DTPA.

1055. In the course of its business, Defendants concealed and suppressed material facts concerning the Fuel Pump Defect. Defendants falsely represented the quality of the Affected Vehicles and omitted material facts regarding the fuel pump, as well as the durability and overall value of the Affected Vehicles, for the purpose of inducing Plaintiffs and other Wisconsin Subclass members to purchase the Affected Vehicles, and to increase Defendants revenue and profits.

1056. The facts concealed and omitted by Defendants were material in that a reasonable consumer would have considered them to be important in deciding whether to purchase or lease the Affected Vehicles or pay a lower price. Had Plaintiffs and other Wisconsin Subclass members known of the Fuel Pump Defect, they would not have purchased or leased those vehicles, or would have paid substantially less for the vehicles than they did.

1057. Plaintiffs and the other Class members were injured and suffered ascertainable loss, injury in fact, and/or actual damages as a proximate result of Defendants' conduct in that Plaintiffs and the other Class members overpaid for their Affected Vehicles and did not get the benefit of their bargain, and their Affected Vehicles have suffered a diminution in value. These injuries are the direct and natural consequence of Subaru's misrepresentations, fraud, deceptive practices, and omissions.

1058. Defendants' violations present a continuing risk to Plaintiffs as well as to the general public. Defendants' unlawful acts and practices complained of herein affect the public interest.

1059. Plaintiffs and the Wisconsin Class members seek actual damages, court costs, attorneys' fees and other relief provided for under Wis. Stat. 100.18(11)(b)(2). Because Defendants' conduct was committed knowingly and/or intentionally, Plaintiffs and the Class

members are entitled to treble damages and any other such relief necessary to deter Defendants unlawful conduct in the future.

REQUEST FOR RELIEF

WHEREFORE, Plaintiffs, individually and on behalf of members of the Nationwide Class and State Subclasses, respectfully request that the Court enter judgment in their favor and against Subaru, as follows:

- A. Certification of the proposed Nationwide Class and State Subclasses, including appointment of Plaintiffs' counsel as Class Counsel;
- B. Restitution, including at the election of Class members, recovery of the purchase price of their Affected Vehicles, or the overpayment or diminution in value of their Affected Vehicles;
- C. Damages, including punitive damages, costs, and disgorgement in an amount to be determined at trial, except that monetary relief under certain consumer protection statutes, as stated above, shall be limited prior to completion of the applicable notice requirements;
- D. An order requiring Subaru to pay both pre- and post-judgment interest on any amounts awarded;
- E. An award of costs and attorneys' fees; and
- F. Such other or further relief as may be appropriate.

DEMAND FOR JURY TRIAL

Plaintiffs hereby demand a jury trial for all claims so triable.

Dated: May 5, 2022

Respectfully submitted,

By: /s/ Christopher A. Seeger
Christopher A. Seeger
Christopher L. Ayers
SEEGER WEISS LLP
55 Challenger Road, 6th Floor
Ridgefield Park, New Jersey 07660
Telephone: (973) 639-9100
cseeger@seegerweiss.com
cayers@seegerweiss.com

Scott A. George
SEEGER WEISS LLP
1515 Market Street, Suite 1380
Philadelphia, Pennsylvania 19102
Telephone: (215) 564-2300
sgeorge@seegerweiss.com

James E. Cecchi
Caroline F. Bartlett
Michael A. Innes
Chirali V. Patel
**CARELLA, BYRNE, CECCHI, OLSTEIN,
BRODY & AGNELLO, P.C.**
5 Becker Farm Road
Roseland, New Jersey 07068
Telephone: (973) 994-1700
jcecchi@carellabyrne.com
cbartlett@carellabyrne.com
minnes@carellabyrne.com
cpatel@carellabyrne.com

Steve W. Berman (*pro hac vice*)
Thomas E. Loeser (*pro hac vice*)
Jerrod C. Patterson (*pro hac vice*)
Anthea D. Grivas (*pro hac vice*)
HAGENS BERMAN SOBOL SHAPIRO LLP
1301 Second Avenue, Suite 2000

Seattle, Washington 98101
Telephone: (206) 623-7292
steve@hbsslaw.com
toml@hbsslaw.com
jerrodp@hbsslaw.com

Interim Co-Lead Class Counsel

W. Daniel “Dee” Miles, III (*pro hac vice*)
Demet Basar (*pro hac vice*)
H. Clay Barnett, III (*pro hac vice*)
Lydia Keaney Reynolds (*pro hac vice*)
J. Mitch Williams (*pro hac vice*)
**BEASLEY, ALLEN, CROW,
METHVIN, PORTIS & MILES, P.C.**
272 Commerce Street
Montgomery, Alabama 36104
Telephone: 334-269-2343
Dee.Miles@Beasleyallen.com
Demet.Basar@Beasleyallen.com
Clay.Barnett@BeasleyAllen.com
Lydia.Reynolds@BeasleyAllen.com
Mitch.Williams@BeasleyAllen.com

Timothy G. Blood (*pro hac vice*)
BLOOD HURST & O’REARDON, LLP
501 West Broadway, Suite 1490
San Diego, California 92101
Telephone: 619-338-1100
tblood@bholaw.com

Adam J. Levitt (*pro hac vice*)
John E. Tangren (*pro hac vice*)
Daniel R. Ferri (*pro hac vice*)
DICELLO LEVITT GUTZLER LLC
Ten North Dearborn Street, Sixth Floor
Chicago, Illinois 60602
Telephone: (312) 214-7900
alevitt@dicellolevitt.com
jtangren@dicellolevitt.com

*Additional Counsel for Plaintiffs and the Proposed
Class*